

EC centrifugal fans RadiPac & RadiFit

Product Catalog 2021-05

ebmpapst

engineering a better life



The ebm-papst RadiPac series is now modernized

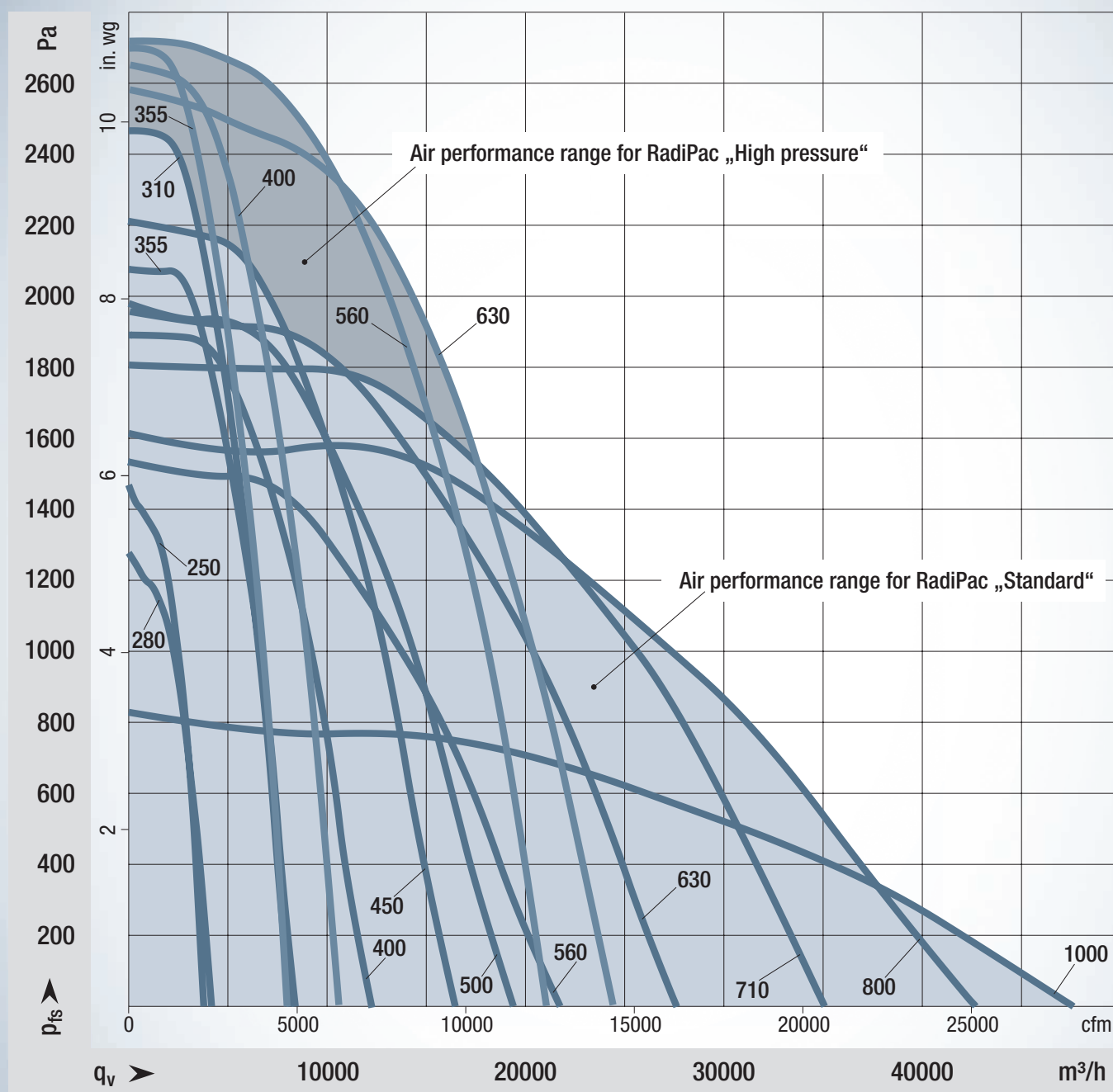

Air performance range for RadiPac "Standard" 250 -1000 and RadiPac "High pressure" 355 - 630

The graph shows the maximum air performance for each size. If less performance is required, variants with smaller motors can be used. This saves additional costs. The right fan for every application!

EC centrifugal fans

RadiPac & RadiFit

ebmpapst

engineering a better life

	Page		Page
Information	4	About ebm-papst / GreenIntelligence	4
		A convincing concept with a wide range of applications / FanScout / Very reliable planning	6
		Product overview	14
RadiPac - Standard 250 - 1000	22	EC centrifugal fans - RadiPac 250 - 355	26
		EC centrifugal fans - RadiPac / FanGrid 400 - 560	54
		EC centrifugal fans - RadiPac 630 - 1000	88
RadiPac - Food service sector 400 - 500	110	Food service sector 400 - 500	114
RadiPac - High pressure 355 - 630	120	High pressure execution 355 - 630	124
RadiPac - ATEX 400 - 630	130	ATEX execution 400 - 630	132
RadiFit 250 - 400	140	EC centrifugal fans - RadiFit 250 - 400	144
Accessories	154	FlowGrid air inlet grill	156
		Intake finger guard	157
		Inlet rings	158
		Vibration absorbers	162
Technology	164	Connection diagrams	166
		Effects of installation space	170
		Airflow determination	171
		Technical parameters & scope	172
Contacts ebm-papst worldwide	178	www.ebmpapst.com/contact	178

Information

EC centrifugal fans - RadiPac - Edition 2021-05

Accessories

Technology

Contacts

About ebm-papst

As the leading supplier of ventilation and drive technology, ebm-papst is a highly respected engineering partner in many industries. With over 20.000 different products, we provide the right solution for just about any challenge.

As the logical next stage in the development of our high-efficiency GreenTech EC technology, we believe that sustainably oriented industrial digitization offers the greatest future prospects for our customers.

With GreenIntelligence, ebm-papst already offers intelligently interconnected complete solutions that are unrivaled worldwide and save energy costs and emissions.

Six reasons why we are your ideal partner:

Our systems expertise.

Of course you always want the best solution for every project. To get it, you need to consider the ventilation and drive engineering aspects as a whole.

And that is precisely what we do...with **motor technology** that sets standards, highly sophisticated **electronics** and **aerodynamically** optimized designs – all from a single source and perfectly matched.

These system solutions release unique synergies worldwide. What's more: they save you a lot of work. Using them means you can concentrate on your core business.

ebm-papst's spirit of invention.

In addition to offering a wide range of products, we are able to develop customized solutions for you at any time. At our three German locations in Mulfingen, Landshut and St. Georgen, a diverse team of 600 engineers and technicians is ready to work to your specifications. Just get in touch with us to discuss your latest project.

Our cutting-edge technology.

ebm-papst is not only a pioneer in developing highly efficient EC technology. We were also quick to recognize the potential of digitalization. This means we are now able to provide solutions that combine maximum energy efficiency with all the advantages of IoT and digital connectivity.

Proximity to our customers.

ebm-papst has 29 worldwide production facilities, including those in Germany, China, the USA, plus 48 sales offices with an extensive network of sales representatives. You always have a local contact who speaks your language and is familiar with your market.

Our quality standards.

Of course you can rely on the top quality of our products. After all, we employ an uncompromising quality management system at every stage of the process. This is documented by our certification in accordance with the DIN EN ISO 9001 and DIN EN ISO 14001 international standards, and the TS declaration of conformity.

Sustainability as a way of life.

Assuming responsibility – for the environment, our employees and society – is an integral part of our corporate philosophy. That is why we develop products designed for maximum environmental compatibility and produce them using processes that preserve resources.

We support environmental awareness among our junior staff and are actively involved in sporting, cultural and educational activities.

All of which makes us a better partner.

GreenIntelligence

Making Engineers Happy



Why do our customers look so happy? Because when it comes to digitalization and sustainability, we provide them with a clear competitive edge with GreenIntelligence. The intelligent control and networking of fans and drives makes applications more powerful and efficient. Together with a long product life and highly efficient EC technology, we achieve lasting reductions in energy costs and emissions.

For **industrial ventilation technology**, solutions are in demand that ensure top performance and operational reliability in every situation. GreenIntelligence gives you robust fan solutions with intelligent networking capabilities that provide reliable performance data and extensive control and monitoring functions. They ensure high levels of efficiency and system availability while guaranteeing maximum data security.

With our **comprehensive range of services**, we accompany you and your projects through every step in the process, from your application's planning to its deployment. Make use of our experts' product expertise to offer your customers new and advanced features. Or use our digital tools for optimal product selection. That will make your processes more efficient and get your products to market faster.

Now you know why ebm-papst makes engineers happy.

Information

Here is how much GreenIntelligence there is in RadiPac:

- Monitoring of motor and ambient temperature
- Precise setting of air flow and operating points
- Automatic condition monitoring
- Fan as a sensor



Pablo improves the performance of his ventilation systems even when they are already in operation.



A convincing concept with a wide range of applications

RadiPac stands for ...

Realistic performance figures, because performance data is always measured for the entire fan consisting of high-performance impeller, GreenTech EC motor and control electronics.

Effective logistics, because a single RadiPac part number covers all the components required for your ventilation application – that's „one-stop shopping“.

Easy installation, because all the functions required for operation are already incorporated and coordinated. Simply connect using plug & play: that's it.

Incidentally, the term RadiPac is made up of the German term „Radialventilator“, meaning centrifugal fan, and the word „package“, meaning a unit: it's a ready-to-integrate, perfectly coordinated, complete package that is easy to install.

Simple and safe.

The electronics and motor form a single unit, which not only saves space but also makes for simple installation. For instance, integrated commutation and control electronics take the place of an external variable frequency drive. And, because the motor and the electronics are already perfectly coordinated in the motor system, there is no need for any additional electronic filters and shielded cables. An external motor protection switch is not required either. To sum up: No expensive adjustment work on commissioning, and no grounding and shielding necessary. That's how easy it is with plug & play.

Compact design.

The high-performance impeller is mounted directly on the rotor of the external rotor motor. This saves space and allows the entire rotating unit to be balanced in a single clamping operation.

Consistent series.

The fans completely cover all nominal sizes from 250 to 1000 and are available quickly. Sizes 250 and 280 are equipped with impellers made of high-quality composite material, manufactured in the injection molding process. Sizes 310 to 1000 have a high-efficiency aluminum impeller with airfoil blades. The entire series was designed for maximum efficiency with a low noise level at the same time. Sustainable production and resource conservation was also given high importance, for example our highly efficient Green-Tech EC motor is designed without the need for rare earth magnets.

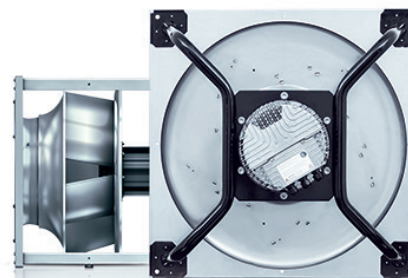

Design variants

Motorized impellers are available in sizes 250 to 800 in combination with all motor sizes up to motor size 150. In addition to an inlet ring, an appropriately dimensioned motor mount must be provided on site to operate a motor-impeller.



RadiPacs with a support bracket are also available in sizes 250 to 560 in all impeller/motor combinations as ready-to-install support struts for wall mounting.

In sizes 630 to 800, these versions are only available in combination with the lightweight size 150 motor. The support bracket design includes the motor-impeller, a welded support strut design, an inlet ring and a square mounting plate.



RadiPacs with a cube design with impeller diameters 630 to 1000 and the „large“ size 200 motor are only available in the cube design intended for floor mounting.

The struts are extruded aluminum profiles, the corner joints are made of die-cast aluminum, and the motor mounting plate, inlet ring and nozzle plate are made of galvanized sheet steel.

This version is not suitable for wall mounting.



FanGrid modules are RadiPac centrifugal fans with a support bracket in a special cube design.

The pre-assembled units in sizes 400 to 560 were designed for setting up the „FanGrid“.

They are suitable for applications with very high volumes of air that cannot be achieved by a single fan with the required compact design.



Additional functions and special designs

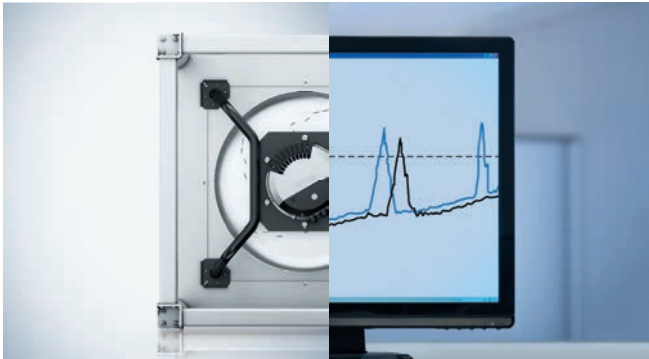

RadiPac with resonance detection:
Longer service life thanks to condition monitoring.

Increased functionality:

- Simple status monitoring and vibration analysis
- Test start-up during commissioning, including resonance point detection
- Suggestion for suppression of critical speed ranges

Intuitive operation:

- Full control over all settings and activities
- Hardware and software from a single supplier

Longer service life and lower maintenance costs:

- High vibration ranges are automatically avoided
- Warning in case of permanent imbalance

RadiPac centrifugal fans with the large 8kW electronics are equipped with condition monitoring as standard. RadiPacs in impeller diameters 400 to 560 can be ordered with resonance detection as an option. Thanks to their perfectly integrated system and plug & play, installation is very simple, so is the digital connection for using the functions described with the EC-Control control software. Even integration into existing building management systems is child's play thanks to the MODBUS RTU interface.



FanGrid design kit:
modular solutions for high air performance levels.

To achieve high air performance in ventilation technology, instead of large individual fans, we are increasingly relying on small fans operated in parallel in „FanGrids“. This type of arrangement is very flexible and efficient. What's more, the redundancy ensures a high level of operational reliability; if one fan fails, the other fans compensate for the missing air quantity. The GreenTech EC fans offered by ebmpapst also help to significantly reduce operating costs.

Another advantage is that the air flows more evenly through upstream – and especially downstream – components such as filters and heat exchangers. This results in more efficient air filtering and improved heat transfer performance. Several small fans also require less space and are lighter than a single large fan. This reduces the cost of the system and makes replacing the fans simple.

An important factor that tends to be overlooked in practice is the risk of installation losses. If fans are installed too closely together, they tend to influence one another. The rule of thumb is that the greater the volume of air that the fan has to convey, the further apart the fans should be. The dimensions of the FanGrid module with cube design are very generous and large enough to prevent installation losses.



RadiPac for restaurants and process exhaust air: clean air according to standards.

When preparing food in commercial kitchens, the ambient air is severely contaminated, e.g. due to grease components and combustion gases, as well as heat and moisture. As a result, the air quality quickly has a questionable level of hygiene, even in areas where the food is being handed out and across the entire dining room, without mentioning the unpleasant odors it creates. Legislation therefore requires AHUs to be installed. They extract foreign substances, moisture and odors from the air and bring in cool, clean air from outside.

Optimized for kitchen exhaust air.

In contrast to the normal RadiPac, the motor and control electronics have been removed from the contaminated air flow in this special design in accordance with VDI 2052 and EN 1682, effectively preventing a layer of grease or oil from building up. Furthermore, the motor and controls are designed according to EN 60335-1 (Household and similar electrical appliances – Safety). This standard must also be satisfied in the commercial sector if the devices are operated by non-experts and can therefore become a source of danger.

Optimum cooling included.

Thanks to the underpressure upstream of the fan compared to the surroundings, cool ambient air is drawn in through a hose to cool the encapsulated motor. This means that the fan and the control system achieve their full output and high flow medium temperatures can be allowed at a corresponding cooling air temperature.



RadiPac with high static pressure: Ventilate buildings efficiently.

Air-handling units for large buildings like airports, skyscrapers or hotels face a special challenge: since residential and commercial real estate are becoming increasingly expensive, centralized and space-saving solutions are generally preferred. This means that the air has to travel long distances through external pressure elements and through long air ducts to reach its destination. It becomes even more problematic if it has to flow through additional „obstacles“, such as activated carbon filters, heat exchangers or separators (internal pressure losses). Fans with an especially high static pressure increase are needed for all of these cases, and they need to be compact, efficient and reliable.

(Air) resistance is futile.

To provide a reliable solution for AHU customers looking to ventilate and air-condition large buildings, ebm-papst has improved its popular RadiPac product range to meet their special requirements. The result is high-performance centrifugal fans with a static pressure increase of up to 2500 Pa, i.e. 15000 m³/h, and is available in sizes 355, 400, 560 and 630.

Of course the new fans offer the series' many other advantages, including its high reliability, energy-efficiency and compactness. And the rugged cube design is available as an option again. Just install, connect with plug & play, and „turn up the pressure“.

Other variants

RadiPac with active PFC.

Sizes 450, 500 and 560 are also available with the 3kW EC motor for three-phase supply networks with integrated active PFC. With these products, we can now fulfill the increasingly frequent requests for total harmonic distortion of no more than 5 % ($THDi \leq 5\%$).

RadiPac with new 112 and 150 motors.

Sizes 310 to 800 have been equipped with 112 and 150 EC motors with 4 kW & 8 kW control electronics from the third Generation (Gen. III). These variants have been optimized for high power density and minimal installation space.

RadiPac with increased corrosion protection.

The ready-to-install centrifugal fans are also available in sizes 250 to 800 with additional corrosion protection measures. This applies to both the centrifugal module with support bracket and the cube design. In these versions, all metal surfaces have an additional coating. The color used is black.

RadiPac with reversed nozzle plate.

Centrifugal fans with a support bracket are available in sizes 310 to 800 in an additional mechanical design with a reversed nozzle plate.

In the standard version, the circumferential chamfer on the mounting plate faces upstream.

In the reversed version, the chamfer points downstream.

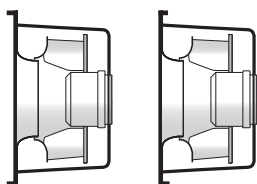

ATEX fans.

ebm-papst offers specially protected RadiPacs for use in potentially explosive atmospheres available in sizes 400 to 630. It is unique for a highly efficient EC motor with integrated control electronics to also be suitable for use in potentially explosive atmospheres of zones 1 and 2, making it easier to use fans in the environment mentioned.

RadiFit EC centrifugal fans: compact, efficient, easy to retrofit.

Our RadiFit centrifugal fans with scroll housing and backward-curved blades is the ideal system solution for a wide range of industrial and ventilation technology applications. With their highly efficient GreenTech EC motors, they can offer excellent efficiency at high pressures. They are light, robust and have the same installation dimensions as the industry standard. So installation and replacement are child's play.

Typical air conditioning and industrial applications:

Low-profile air conditioners are used in air conditioned buildings to temper the supply air using the warm exhaust air. For this purpose, fans convey the air through the heat exchanger and then through the inlet and exhaust air ducts. Our RadiFit is compact, can be adjusted flexibly and is highly efficient, so it satisfies strict energy conservation regulations.

In **central air-conditioning units**, the air must be transported through various components such as filters, heat exchangers, humidifiers and branched duct systems. The fans have to compensate for the high pressure losses. The system should also save as much space as possible and permit simple, demand-based ventilation for a large number of rooms. No problem for the RadiFit.

For **cooling generators**, a fan forces the ambient air through narrow ducts on the generator to cool it. The RadiFit's integrated speed control means that cooling can always be adapted to the load or heat generation. The fan requires very little space, as no separate control unit is required. And it's maintenance-free too!



ebm-papst FanScout: click your way to the optimum RadiPac

Our radial fans can be configured individually for each application, and it is important to correctly consider all the relevant aspects when selecting your axial fan. When making your selection, you can rely on our experts' many years of experience, and on our professional fan selection software as well:

With its outstanding user-friendliness and real measured values, the ebm-papst FanScout has more than proven its worth already. It not only measures the performance of the individual fan components but also that of the fan as a complete system. The program allows you to quickly select the best fan for your application, to describe and modify the operating behavior and to document the technical specifications. Factors such as air performance, operating time and installation space can be taken into account in this process. TÜV SÜD has tested the difference between the actu-

al measurements and the data calculated using the software and assigned the accuracy of the calculation to the highest class.

Exact presentation of the life cycle costs:

The costs of operation, acquisition, installation and service can be calculated for a defined period of time.

A practical advantage:

The software can be easily integrated into your device configuration program using the DLL interface.

The best part:

ebm-papst pre-selects the products that are suitable for you. This saves you the trouble of searching through the broad product portfolio and helps you configure your application in advance.



Would you like to find out more?

All products from this catalog are collated into a collection in FanScout. We will be pleased to provide you with this collection on request. Or perhaps you have another question? Then get in touch with us for more information:

Ralf Mühleck, Tel. +49 7938 81-7035, Ralf.Muehleck@de.ebmpapst.com
or follow us at www.ebmpapst.com/radipac

Very reliable planning thanks to credible data

Regular checks

To ensure that the measurements are always accurate and reproducible, test facilities and test equipment undergo regular checks. It is standard practice at ebm-papst for Quality Assurance to routinely monitor test equipment with measurement quantities traceable to national and international standards (German Calibration Service DKD, German National Metrology Institute PTB). The air flow is identified and regular leak testing is performed based on ISO 5801. Since the middle of 2014, calibration of the air flow measuring instruments and traceability to the national standard of the PTB have also formed part of the quality assurance process. The applicable range is from 100 m³/h to 40.000 m³/h with a reference measuring instrument accuracy of ±0,5 % of the measured value. Internal validation provides both assurance for the company and information for customers. The documentation is available for viewing at all times.

Always find the right fan with the FanScout selection software:

If a fan is not powerful enough, there is an inadequate air flow rate. If it is too powerful, it has an unnecessary energy consumption. The ideal way to find exactly the right solution for specific requirements is to use reliable fan selection software like FanScout from ebm-papst.

The ebm-papst FanScout enables users to quickly select the best fan for the application concerned, to display and alter the operating characteristics and to record technical data. Factors such as air performance, operating time and installation space can be taken into account. The software contains valuable measurement data that help considerably in selecting just the right fan. The best part: ebm-papst pre-selects the products that are suitable for you. This saves you the trouble of searching through the extensive product portfolio and helps you configure your application in advance.

Physical quantity	Measuring range/unit	Measurement accuracy
Pressure increase p_{sf}	0 to 3.000 Pa	0,5% of measured value
Air flow q_v	100 to 100.000 m ³ /h	1% of measured value
Air power P_u	kW	1,2% of measured value
Power consumption P_e	0 to 30 kW	0,5% of measured value
Torque M	0 to 200 Nm	1% of measured value
Overall efficiency e	%	1,3 percentage points
Speed N	0 to 99.999 min ⁻¹	1 min ⁻¹
Air density	approx. 1,2 kg/m ³	0,1% of measured value
Sound power L_{wA}	from 30 dB(A)	1 dB(A)

Test stand design and tests in accordance with ISO 5801 – Industrial fans, performance measurement on standardized test stands DIN EN ISO 3744, DIN EN ISO 3745, ISO 13347-3 – Acoustics standards

Measurement quantities and measurement accuracies attained with the aero-acoustic test stand.

TÜV Süd has confirmed that the test stand satisfies all the requirements of DIN EN ISO 5801 in an air flow range from 500 m³/h to 39.000 m³/h and with a pressure increase of up to 1.000 Pa. The Fraunhofer Institute in Stuttgart approved the acoustic properties of the combination test stand. The institute confirmed the Class 1 rating for the ebm-papst noise measurement chamber.





Certified accuracy.

The inspection authorities (TÜV Süd) have confirmed the outstanding accuracy of the performance data supplied. Validation measurements on all catalog types in the RadiPac product range have shown that, on average, the efficiency level given by the FanScout tends to be lower rather than too high. How were the validation measurements conducted? 15 reference points were selected for each fan in the RadiPac product range and measurements were then taken on the certified chamber test rig. Comparison of the measured air performance data with the data from the FanScout revealed that the calculated values from the FanScout were almost identical to those measured under real conditions. According to the AHU directive 01, RadiPac fans therefore satisfy the requirements of the best possible accuracy class B0. This means that, in their as-delivered condition, ebm-papst RadiPac fans tend to have a higher efficiency level than that shown by the FanScout. This guarantees really reliable planning.

The RadiPac product range achieves the calculation accuracy B0. The classes are classified as shown in the following table:

Operating value	Limit deviation and classification		
	B0	B1	B2
Air flow	±1%	±2,5%	±5%
Pressure increase	±1%	±2,5%	±5%
Drive power	+2%	+3%	+8%
Efficiency	-1%	-2%	-5%

The calculation accuracy class determined by TÜV SÜD must be better than the delivery class specified by the manufacturer. Otherwise, the delivery class – and the correction factor for P_m – must be graded.

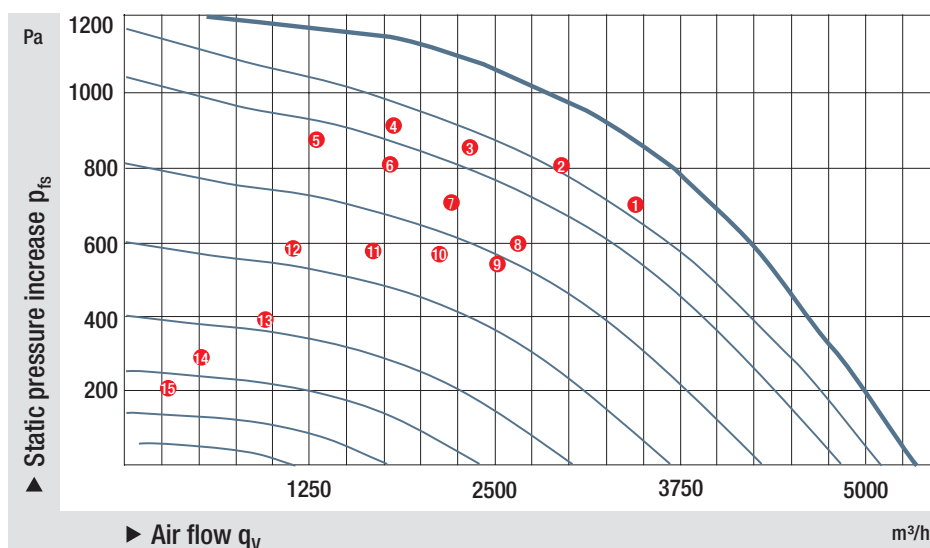

Validation test on a total of 38 different fan types from ebm-papst;
 Example:
 Map of a type from the FanScout (K3G310-AX69-01, Test_Id. 159632, 159973)

①...⑮ Reference points:
 Randomly selected operating points for measuring the actual power consumption



— Nominal speed
 — Reduced speed

EC centrifugal fans & modules

"RadiPac - Standard" 250 - 450

Information

EC centrifugal fans - RadiPac (backward curved, Standard)



Size	Nominal voltage range VAC	Max. input power W	Centrifugal fan 		Centrifugal module with support bracket 		Centrifugal module with cube design 		on Page
			Type	Part number	Type	Part number	Type	Part number	
250	1-200-277	500	VBS0250PSPGS	R3G250PR04H1	VBH0250PSPGS	K3G250PR04H2	---	---	26
	1-200-277	750	VBS0250PSPGS	R3G250PR17I1	VBH0250PSPGS	K3G250PR17I2	---	---	
	3-380-480	1180	VBS0250PTPGS	R3G250PR02J1	VBH0250PTPGS	K3G250PR02J2	---	---	
280	1-200-277	500	VBS0280PSPGS	R3G280PR03H1	VBH0280PSPGS	K3G280PR03H2	---	---	32
	1-200-277	750	VBS0280PSPGS	R3G280PR04I1	VBH0280PSPGS	K3G280PR04I2	---	---	
	3-380-480	1050	VBS0280PTPKS	R3G280PS10J1	VBH0280PTPKS	K3G280PS10J2	---	---	
310	1-200-277	1500	VBS0310PSRHS	R3G310PG5721	VBH0310PSRHS	K3G310PG5728	---	---	38
	1-200-277	1500	VBS0310PSRHS	R3G310PG9321	VBH0310PSRHS	K3G310PG9321	---	---	
	3-380-480	1230	VBS0310PTPMS	R3G310PT08J1	VBH0310PTPMS	K3G310PT08J2	---	---	
	3-380-480	1370	VBS0310PTPMS	R3G310PT10W1	VBH0310PTPMS	K3G310PT10W1	---	---	
	3-380-480	3050	VBS0310PTRLS	R3G310PV6903	VBH0310PTRLS	K3G310PV6903	---	---	
	3-380-480	3000	VBS0310PTRLS	R3G310PV6902	---	---	---	---	
	3-380-480	4100	VBS0310PTRLS	R3G310PV7304	---	---	---	---	
355	1-200-277	1500	VBS0355PSRLS	R3G355PH3821	VBH0355PSRLS	K3G355PH3822	---	---	46
	1-200-277	1500	VBS0355PSHRS	R3G355PG5421	VBK0355PSHRS	K3G355PG5422	---	---	
	3-380-480	1300	VBS0355PTPMS	R3G355PT12W1	VBH0355PTPMS	K3G355PT12W1	---	---	
	3-380-480	2900	VBS0355PTRLS	R3G355PV7001	VBH0355PTRLS	K3G355PV7001	---	---	
	3-380-480	2900	VBS0355PTRLS	R3G355PV7002	---	---	---	---	
400	3-380-480	3750	VBS0355PTRNS	R3G355PW0701	---	---	---	---	54
	3-380-480	3400	VBS0400PTRNS	R3G400PW0301	VBK0400PTRNS	K3G400PW0301	---	---	
	3-380-480	3650	VBS0400PTTLS	R3G400PA2703	VBH0400PTTLS	K3G400PA2703	VBH0400PTTLS	K3G400PA27W4	
	3-380-480	3650	VBS0400PTTLS ¹⁾	R3G400PA2765 ¹⁾	---	---	VBH0400PTTLS ¹⁾	K3G400PA27W5 ¹⁾	
450	3-380-480	4400	VBS0400PTTLS	R3G400PA2702	---	---	---	---	60
	3-380-480	2650	VBS0450PTRNS	R3G450PW1202	---	---	---	---	
	3-380-480	2650	VBS0450PTRNS	R3G450PW1201	VBH0450PTRNS	K3G450PW1201	---	---	
	3-380-480	3190	VBS0450PTTLS ²⁾	R3G450PA21C1 ²⁾	VBH0450PTTLS ²⁾	K3G450PA21C1 ²⁾	---	---	
	3-380-480	4450	VBS0450PTTLS	R3G450PA3102	---	---	---	---	
	3-380-480	4450	VBS0450PTTLS	R3G450PA3103	VBH0450PTTLS	K3G450PA3103	VBH0450PTTLS	K3G450PA31W3	
	3-380-480	4450	VBS0450PTTLS ¹⁾	R3G450PA3165 ¹⁾	---	---	VBH0450PTTLS ¹⁾	K3G450PA31W5 ¹⁾	
3-380-480	6800	VBS0450PTTPS ¹⁾	R3G450PB29L1 ¹⁾	VBH0450PTTPS ¹⁾	K3G450PB29L1 ¹⁾	VBH0450PTTPS ¹⁾	K3G450PB29N3 ¹⁾		

¹⁾ Centrifugal fan & FanGrid with resonance sensor ²⁾ With active PFC

EC centrifugal fans & modules

"RadiPac - Standard" 500 - 1000

EC centrifugal fans - RadiPac (backward curved, Standard)

Size	Nominal voltage range VAC	Max. input power W	Centrifugal fan 		Centrifugal module with support bracket 		Centrifugal module with cube design 		on Page
			Type	Part number	Type	Part number	Type	Part number	
500	3-380-480	2350	VBS0500PTRNS	R3G500PW0901	VBH0500PTRNS	K3G500PW0901	---	---	70
	3-380-480	3100	VBS0500PTTLS ²⁾	R3G500PA26C1 ²⁾	VBH0500PTTLS ²⁾	K3G500PA26C1 ²⁾	---	---	
	3-380-480	3350	VBS0500PTTLS	R3G500PA2803	VBH0500PTTLS	K3G500PA2803	---	---	
	3-380-480	3900	VBS0500PTTPS	R3G500PB2402	---	---	---	---	
	3-380-480	3900	VBS0500PTTPS	R3G500PB2403	VBH0500PTTPS	K3G500PB2403	VBH0500PTTPS	K3G500PB24W3	
	3-380-480	3900	VBS0500PTTPS ¹⁾	R3G500PB2465 ¹⁾	---	---	VBH0500PTTPS ¹⁾	K3G500PB24W5 ¹⁾	
	3-380-480	7000	VBS0500PTTRS ¹⁾	R3G500PC16L1 ¹⁾	VBH0500PTTRS ¹⁾	K3G500PC16L1 ¹⁾	VBF0500PTTRS ¹⁾	K3G500PC16N3 ¹⁾	
560	3-380-480	3060	VBS0560PTTPS ²⁾	R3G560PB22C1 ²⁾	VBH0560PTTPS ²⁾	K3G560PB22C1 ²⁾	---	---	80
	3-380-480	4400	VBS0560PTTPS	R3G560PB3102	---	---	---	---	
	3-380-480	4250	VBS0560PTTPS	R3G560PB3103	VBH0560PTTPS	K3G560PB3103	VBH0560PTTPS	K3G560PB31W3	
	3-380-480	4250	VBS0560PTTPS ¹⁾	R3G560PB3165 ¹⁾	---	---	VBH0560PTTPS ¹⁾	K3G560PB31W5 ¹⁾	
	3-380-480	5950	VBS0560PTTRS ¹⁾	R3G560PC10L1 ¹⁾	VBH0560PTTRS ¹⁾	K3G560PC10L1 ¹⁾	VBF0560PTTRS ¹⁾	K3G560PC10N3 ¹⁾	
630	3-380-480	4250	VBS0630PTTRS	R3G630PC0803	VBH0630PTTRS	K3G630PC0803	---	---	88
	3-380-480	5250	VBS0630PTTRS ¹⁾	R3G630PC04L1 ¹⁾	VBH0630PTTRS ¹⁾	K3G630PC04L1 ¹⁾	---	---	
	3-380-480	7060	---	---	---	---	VBF0630PTVNS	K3G630PV0401	
	3-380-480	9780	---	---	---	---	VBF0630PTVQS	K3G630PW0401	
710	3-380-480	3750	VBS0710PTTRS	R3G710PC0503	VBH0710PTTRS	K3G710PC0503	---	---	94
	3-380-480	7050	---	---	---	---	VBF0710PTVQS	K3G710PV0501	
	3-380-480	11450	---	---	---	---	VBF0710PTVTS	K3G710PW0601	
800	3-380-480	2800	VBS0800PTTRS	R3G800PC0203	VBH0800PTTRS	K3G800PC0203	---	---	100
	3-380-480	7950	---	---	---	---	VBF0800PTVTS	K3G800PV1301	
	3-380-480	11300	---	---	---	---	VBT0800PTVTS	K3G800PW0701	
1000	3-380-480	6340	---	---	---	---	VBF1000PTVTS	K3GA00PV0301	106



¹⁾ Centrifugal fan & FanGrid with resonance sensor ²⁾ With active PFC

Subject to technical changes.

EC centrifugal modules "RadiPac - Standard"



with support bracket & reversed nozzle plate 310 - 800
with support bracket & improved corrosion protection 250 - 560

EC centrifugal fans - RadiPac (with reversed nozzle plate / improved corrosion protection)

Size	Nominal voltage range VAC	Max. input power W	Centrifugal module with support bracket and reversed nozzle plate 		Centrifugal module with support bracket and improved corrosion protection 	
			Type	Part number	Type	Part number
250	1-200-277	500	---	---	VBH0250PSPGS	K3G250PR04H3
	1-200-277	750	---	---	VBH0250PSPGS	K3G250PR17I3
	3-380-480	1180	---	---	VBH0250PTPGS	K3G250PR02J3
280	1-200-277	500	---	---	VBH0280PSPGS	K3G280PR03H3
	1-200-277	750	---	---	VBH0280PSPGS	K3G280PR04I3
	3-380-480	1050	---	---	VBH0280PTPKS	K3G280PS10J3
310	1-200-277	1500	VBH0310PSRHZ	K3G310PG5726	---	---
	1-200-277	1500	VBH0310PSRHS	K3G310PG9327	---	---
	3-380-480	1230	VBH0310PTPMS	K3G310PT08J4	VBH0310PTPMS	K3G310PT08J3
	3-380-480	1370	VBH0310PTPMS	K3G310PT10W2	---	---
	3-380-480	3050	VBH0310PTRLS	K3G310PV6905	---	---
355	1-200-277	1500	VBK0355PSRLS	K3G355PH3825	---	---
	1-200-277	1500	VBH0355PSRHS	K3G355PG5426	---	---
	3-380-480	1300	VBH0355PTPMS	K3G355PT12W2	---	---
	3-380-480	2900	VBH0355PTRLS	K3G355PV7005	---	---
400	3-380-480	2700	VBK0400PTRNS	K3G400PW0305	---	---
	3-380-480	3650	VBH0400PTTLS	K3G400PA2762	VBH0400PTTLS	K3G400PA2733
	3-380-480	3650	VBH0400PTTLS ¹⁾	K3G400PA2765 ¹⁾	---	---
450	3-380-480	2650	VBH0450PTRNS	K3G450PW1205	---	---
	3-380-480	4450	VBH0450PTTLS	K3G450PA3161	VBH0450PTTLS	K3G450PA3133
	3-380-480	4450	VBH0450PTTLS ¹⁾	K3G450PA3165 ¹⁾	---	---
	3-380-480	6800	VBH0450PTTPS	K3G450PB29N1	---	---
500	3-380-480	2350	VBH0500PTRNS	K3G500PW0905	---	---
	3-380-480	3350	VBH0500PTTLS	K3G500PA2805	---	---
	3-380-480	3900	VBH0500PTTPS	K3G500PB2461	VBH0500PTTPS	K3G500PB2433
	3-380-480	3900	VBH0500PTTPS ¹⁾	K3G500PB2465 ¹⁾	---	---
	3-380-480	7000	VBH0500PTTRS	K3G500PC16N1	---	---
560	3-380-480	4250	VBH0560PTTPS	K3G560PB3161	VBH0560PTTPS	K3G560PB3133
	3-380-480	4250	VBH0560PTTPS ¹⁾	K3G560PB3165 ¹⁾	---	---
	3-380-480	5950	VBH0560PTTRS	K3G560PC10N1	---	---

¹⁾ Centrifugal module with resonance sensor

EC centrifugal fans - RadiPac (with reversed nozzle plate / improved corrosion protection)

Size	Nominal voltage range VAC	Max. input power W	Centrifugal module with support bracket and reversed nozzle plate 		Centrifugal module with support bracket and improved corrosion protection 	
			Type	Part number	Type	Part number
630	3-380-480	4250	VBH0630PTTRS	K3G630PC0804	---	---
710	3-380-480	3750	VBH0710PTTRS	K3G710PC0505	---	---
800	3-380-480	2800	VBH0800PTTRS	K3G800PC0205	---	---



Subject to technical changes.

The products listed on this double page are not shown in the catalog.

EC centrifugal modules "RadiPac - Standard"

with support bracket, reversed nozzle plate & improved corrosion protection 400 - 560

with cube design & improved corrosion protection 630 - 800

EC centrifugal fans - RadiPac (with reversed nozzle plate / improved corrosion protection)						
Size	Nominal voltage range VAC	Max. input power W	Centrifugal module with support bracket, reversed nozzle plate and improved corrosion protection 		Centrifugal module with cube design & improved corrosion protection 	
			Type	Part number	Type	Part number
400	3-380-480	3650	VBH0400PTTLS	K3G400PA2734	---	---
450	3-380-480	4450	VBH0450PTTLS	K3G450PA3134	---	---
500	3-380-480	3900	VBH0500PTTTPS	K3G500PB2434	---	---
560	3-380-480	4400	VBH0560PTTTPS	K3G560PB3134	---	---
630	3-380-480	7060	---	---	VPF0630PTVNS	K3G630PV0402
	3-380-480	9780	---	---	VPF0630PTVQS	K3G630PW0402
710	3-380-480	7050	---	---	VPF0710PTVTS	K3G710PV0502
	3-380-480	11450	---	---	VPF0710PTVTS	K3G710PW0602
800	3-380-480	7950	---	---	VPF0800PTVTS	K3G800PV1302
	3-380-480	11300	---	---	VPF0800PTVTS	K3G800PW0702

Subject to technical changes.

The products listed on this page are not shown in the catalog.



EC centrifugal modules "Food service sector & High pressure"

with cube design - Food service sector 400 - 500
 with support bracket - High pressure 355 - 400
 with cube design - High pressure 560 - 630

EC centrifugal fans - RadiPac (for the food service sector and process exhaust air)

Size	Nominal voltage range VAC	Max. input power W	Centrifugal module with cube design 		on Page
			Type	Part number	
400	3-380-480	3000	VBH0400NTTLS	K3G400AQ27K1	114
450	3-380-480	2780	VBH0450NTTLS	K3G450AQ23K1	
500	3-380-480	3000	VBH0500NTTLS	K3G500AP28K1	

EC centrifugal fans - RadiPac (High pressure execution)



Size	Nominal voltage range VAC	Max. input power W	Centrifugal module with support bracket 		Centrifugal module with cube design 		on Page
			Type	Part number	Type	Part number	
355	3-380-480	4700	VBH00355NTTLS	K3G355HA3401	---	---	124
400	3-380-480	6000	VBH0400NTTTPS	K3G400HB4101	---	---	
560	3-380-480	12000	---	---	VPF0560NTVQS	K3G560HE0701	
630	3-380-480	13750	---	---	VPF0630NTVTS	K3G630AT0911	

Subject to technical changes.

EC centrifugal modules "RadiPac - ATEX"

with cube design - ATEX 400 - 630

EC centrifugal fans - RadiPac (backward curved, ATEX execution)

Size	Nominal voltage range VAC	Max. input power W	Centrifugal module with cube design  		on Page
			Type	Part number	
400	3-380-480	2100	VBF0400NTTLS	K3G400AQ2390	132
450	3-380-480	2950	VBF0450NTTLS	K3G450AQ2490	
500	3-380-480	2970	VBF0500NTTLS	K3G500AP2590	
560	3-380-480	2940	VBF0560NTTPS	K3G560AP2390	
630	3-380-480	2970	VBF0630NTTRS	K3G630AP0190	

Subject to technical changes.

EC centrifugal modules "RadiPac - RadiFit"

with housing - RadiFit - 250 - 400

EC centrifugal fans - RadiFit (backward curved, with housing)

Size	Nominal voltage range VAC	Max. input power W	Centrifugal fan - RadiFit with housing		on Page
			Type	Part number	
250	3-380-480	1810	VCD0250FTPMS ¹⁾	D3G250GG0901 ¹⁾	144
280	3-380-480	1320	VCD0280FTPMS ¹⁾	D3G280GG1001 ¹⁾	
310	3-380-480	3180	VCD0310FTRNS ¹⁾	D3G310GG0501 ¹⁾	
	3-380-480	3180	VCD0310FTRNS ²⁾	D3G310GG0504 ²⁾	
355	3-380-480	3160	VCD0355FTRNS ¹⁾	D3G355GG0301 ¹⁾	
	3-380-480	3160	VCD0355FTRNS ²⁾	D3G355GG0304 ²⁾	
400	3-380-480	2380	VCD0400FTRNS ¹⁾	D3G400GG0401 ¹⁾	
	3-380-480	2380	VCD0400FTRNS ²⁾	D3G400GG0404 ²⁾	

¹⁾ RadiFit with mounting bracket ²⁾ RadiFit with mounting frame

Subject to technical changes.

RadiPac - Standard:

Type R3G... RadiPac motorized impellers are available in sizes 250 to 560 for all impeller/motor combinations. For sizes 630 to 800, these versions are only available in combination with the lightweight size 150 motor. Operation of a type R3G... motorized impeller requires an inlet ring and a motor mounting of suitable dimensions to be provided by the customer.

Type K3G... centrifugal fans are also available in sizes 250 to 560 and for all impeller/motor combinations in a ready-to-install design with support struts for wall mounting. For sizes 630 to 800, these versions are only available in combination with the lightweight size 150 motor. The K3G "spider" design includes the motorized impeller, a welded support strut assembly, an inlet ring and a square mounting plate.

Type K3G... centrifugal fans with impeller diameters 630 to 1000 and the "large" size 200 motor are only available in the cube design intended for floor mounting. The struts are extruded aluminum profile, the corner joints are made of die-cast aluminum, and the motor mounting plate, the inlet ring and the nozzle plate are made of galvanized sheet steel. This version is not suitable for wall mounting.

Type K3G (cube for FanGrid) centrifugal fans in sizes 400 to 560 are designed as pre-assembled units for creating so-called FanGrids. These units are suitable for applications with very high volumes of air that cannot be achieved by a single fan with the required compact design. For installation, we recommend the stainless steel mounting elements available as accessories.



RadiPac 250 - 1000

Standard

ebmpapst

engineering a better life

	Page
Tender specification	24
250	26
280	32
310	38
355	46
400	54
450	60
500	70
560	80
630	88
710	94
800	100
1000	106

Tender specification

EC centrifugal fans - RadiPac "Standard"

Fan size 250 to 1000

Direct-drive single inlet centrifugal fans with backwards-curved high-performance centrifugal impellers with radial diffusers, mounted on a GreenTech EC external rotor motor with integrated control electronics.

Impeller made of aluminum, with 5 backwards-curved, continuously welded, hollow-profile blades; impeller sizes 250 and 280 made of plastic; flow-optimized inlet ring made of galvanized sheet steel with pressure tap.

Motorized impeller statically and dynamically balanced on two planes to balancing grade G 6.3 (motor size 200 to balancing grade G 4.0) in accordance with DIN ISO 21940.

GreenTech EC external rotor motors achieve or exceed efficiency class IE5, magnets with no rare earth elements, maintenance-free ball bearings with long-term lubrication, theoretical nominal service life of at least 40.000 hours of operation.

Efficiency level of integrated EC motor equivalent to IE5 according to IEC/TS 60034-30-2 (Rotating electrical machines – Part 30-2: Efficiency classes of variable speed AC motors (IE-Code) (IEC/TS 60034-30-2:2016)

Soft start, integrated current limitation, extended voltage input 1~200-277 V, 50/60 respectively 3~380-480 V, 50/60 Hz. Fan can be used with all standard power supply networks with unaltered air performance. Integrated electronics, low-noise commutation logic; 100 % open-loop speed control; all fans have an RS485/MODBUS RTU interface, and do not need to be installed with shielded cables. All 1~ types have an integrated active PFC (Power Factor Correction) to reduce disturbing harmonic content. Terminal box made of aluminum/plastic with easily accessible connection area with spring-loaded terminals, environment-resistant cable glands, or with external cable (sizes 250 to 280).

Version for wall mounting:

Support bracket, sizes 250 to 560 and 630 to 800 with size 150 motor as ready-to-install support bracket intended for wall mounting. Support bracket made of bent round bar steel or round tube, welded and coated in black. Mounting plate and inlet ring made of sendzimir galvanized sheet steel.

Version for floor mounting:

Cube design, sizes 630 to 1000 with size 200 motor as ready-to-install cube design intended exclusively for floor mounting. Struts made of extruded aluminum sections connected to die-cast corner plates, nozzle plate and inlet ring made of sendzimir galvanized sheet steel, motor mounting plate made of coated sheet steel. This version is not suitable for wall mounting.

Any work required for isolation from structure-borne noise to be performed by the customer. Fan satisfies the applicable EMC guidelines and requirements with regard to circuit feedback (for specific information, see the respective data sheet). Documentation and marking conform to the applicable EU Directives.

Reliable performance data, air performance measurements on intake-side chamber test rig according to ISO 5801 and DIN 24163, noise measurements in anechoic rooms according to DIN EN ISO 3745.

Integrated protective devices:

- Alarm relay with zero-potential change-over contacts (250 V AC/2 A, $\cos \varphi = 1$)
- Locked-rotor protection
- Phase failure detection
- Soft start of motors
- Mains under-voltage detection
- Thermal overload protection for electronics and motor
- Short circuit protection

Optional:

- Other and specific requirements on request
- FlowGrid air inlet grill:
FlowGrid air inlet grill tailor-made for the fan, to reduce assembly and system-related noise. Grill made of high-grade composite material in one piece, available ready for installation and also suitable for retrofitting. Ideal solution for confined intake conditions at the fan and/or if upstream turbulence-inducing fittings are unavoidable. The FlowGrid breaks up the turbulence fields and straightens the flow, resulting in distinct noise reduction.

Tender specification

EC centrifugal fans - RadiPac "Standard"

Fan size 250 to 1000

Technical data:

Fan type		= _____ - _____ - _____
Air flow	qV	= _____ m ³ /h, cfm
Stat. pressure increase	pfs	= _____ Pa, in wg
Stat. overall efficiency	η_{es}	= _____ %
Operating speed	n	= _____ min ⁻¹
Motor type		= EC motor
Type of control		= 0-100 % speed control
Motor efficiency class		= IE5
Total power input	Ped	= _____ kW
Specific fan power	SFP	= _____ kW/(m ³ /s)
Nominal voltage range	U _N	= _____ V
Line frequency	f	= 50 / 60 Hz
Nominal current	I _N	= _____ A
Degree of protection		= IP54
Sound power level	L _{WA} (A, in)	= _____ / L _{WA} (A, out) = _____ dB(A)
Sound pressure level (at 1 m)	L _{pA} (A, in)	= _____ / L _{pA} (A, out) = _____ dB(A)
Perm. ambient temperature	T	= _____ to _____ °C
Weight of fan	m	= _____ kg



EC centrifugal fans - RadiPac
Support bracket
Fan size 250 - 800

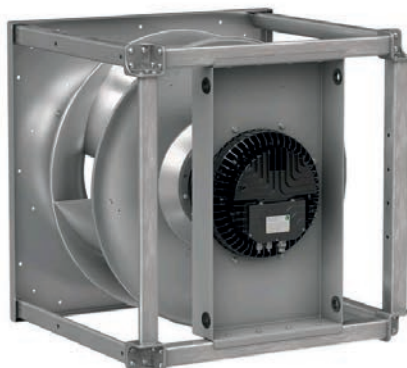

EC centrifugal fans - RadiPac
Cube design
Fan size 630 - 1000



Optionally Flow Grid
Air inlet grill

Refer to data sheet for dimensions and wiring.

RadiPac 250

EC centrifugal fans, backward curved



Material/surface

- Support bracket: Steel, painted black
- Support plate: Sheet steel, galvanized
- Inlet ring: Sheet steel, galvanized
- Impeller: PP plastic
- Rotor: Painted black
- Electronics housing: Die-cast aluminum

Mechanical characteristics

- Number of blades: 6
- Direction of rotation: Clockwise viewed toward rotor
- Installation position: See product drawing
- Condensation drainage holes: Rotor side
- Mode: Continuous operation (S1)
- Mounting: Maintenance-free ball bearings

Further Information





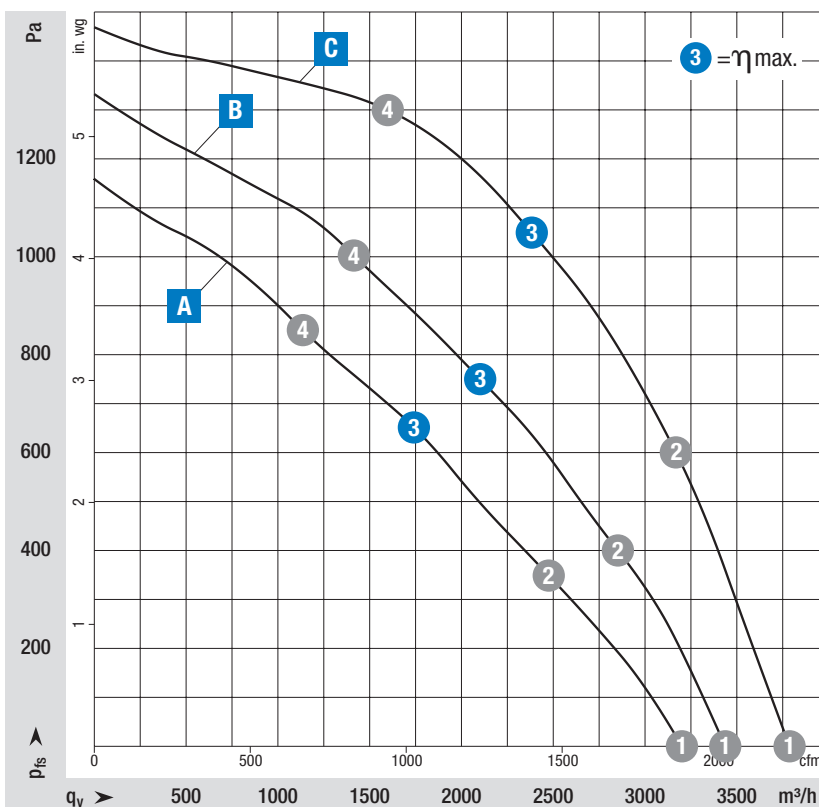



- Information about touch current, electrical connection, degree of protection, insulation class, environmental protection class, EMC standards as well as standards and approvals can be found in the product-specific data sheets.

on Page 28	Drawings
on Page 154	Accessories
on Page 166	Connection diagrams and technical features
on Page 172	Technical parameters & scope
More at	www.ebmpapst.com/worldwide www.ebmpapst.com/radipac



Measuring requirements

Air performance measured according to: ISO 5801, installation category A, with ebm-papst inlet ring without contact protection. Intake-side sound level: L_{wA} according to 13347, L_{wA} measured at 1 m distance from fan axis. The values given are only applicable under the specified measuring conditions and may differ depending on the installation conditions. In the event of deviation from the standard configuration, the parameters must be checked in installed condition.

Curve				Operating point	Nominal voltage	Speed n	Max. Input power P_{in}	Max. Input current I	Sound power level LWA	Perm. ambient temp.	Degree of protection	Conn. diagram	
Nominal voltage range 1-200-277 V AC, 50/60 Hz				VAC	VAC	rpm	W	A	dB(A)	°C			
Type	Part number	Fan type											
A	VBS0250PSPGS	R3G250PR04H1	Centrifugal fan		①	230	3380	490	2,16	84	-25..+40	IP 55	RP2)
					②	230	3125	520	2,29	77			
	③	230	3080	500	2,30	74							
	④	230	3220	500	2,30	78							
VBH0250PSPGS	K3G250PR04H2	Support bracket											
B	VBS0250PSPGS	R3G250PR17I1	Centrifugal fan		①	230	3645	630	2,74	87	-25..+40	IP 55	RP2)
					②	230	3490	730	3,19	82			
	③	230	3450	750	3,30	78							
	④	230	3500	720	3,15	82							
VBH0250PSPGS	K3G250PR17I2	Support bracket											
Nominal voltage range 3-380-480 V AC, 50/60 Hz				VAC	VAC	rpm	W	A	dB(A)	°C			
Type	Part number	Fan type											
C	VBS0250PTPGS	R3G250PR02J1	Centrifugal fan		①	400	4000	820	1,27	91	-25..+40	IP 55	RP3)
					②	400	4000	1110	1,72	86			
	③	400	4000	1180	1,80	83							
	④	400	4000	1060	1,64	83							
VBH0250PTPGS	K3G250PR02J2	Support bracket											

Subject to change

Values set in blue are nominal data at operating point with maximum load.

RadiPac 250

A VBS0250PSPGS R3G250PR04H1 (EC centrifugal fan)

Dimensions in mm

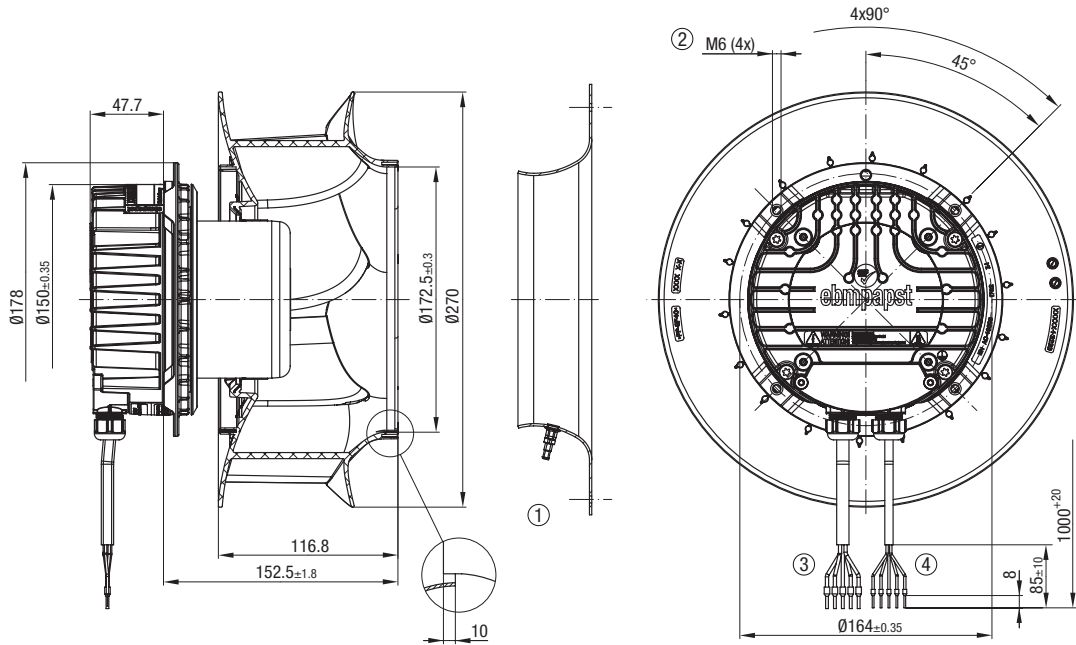

- ① **Accessory part:** Inlet ring 96355-2-4013 with pressure tap (k-factor: 76) not included in scope of delivery (Dimensions: see "Accessories" chapter)
- ② **Max. clearance of screw:** 16 mm
- ③ **Cable:** PVC AWG18, 5x crimped ferrules
- ④ **Cable:** PVC AWG22, 5x crimped ferrules

Pin assignment: (see connection diagram)

Installation position: Shaft horizontal or rotor on bottom, rotor on top on request

A VBH0250PSPGS K3G250PR04H2 (EC centrifugal module with support bracket)

Dimensions in mm

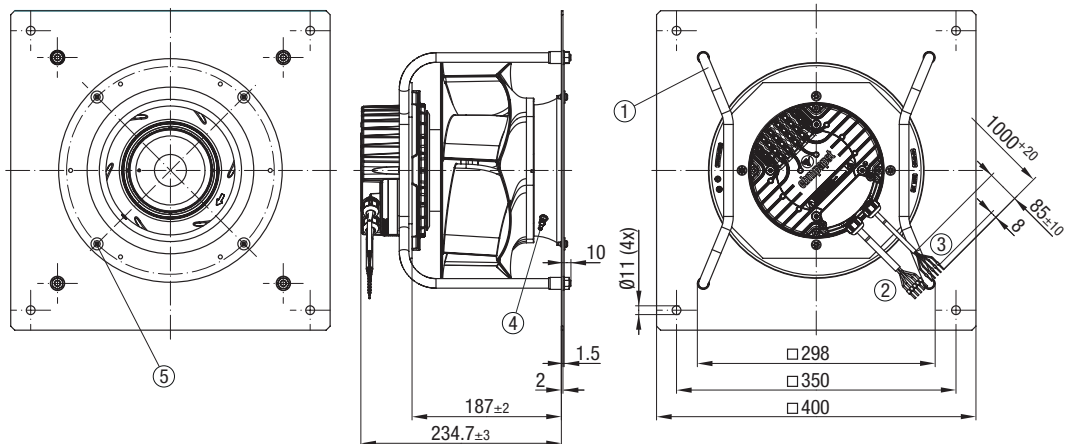

- ① **Installation position:** Shaft horizontal (Install support struts only vertically according to view!) or rotor on bottom, rotor on top on request
- ② **Cable:** PVC AWG18, 5x crimped ferrules
- ③ **Cable:** PVC AWG22, 5x crimped ferrules
- ④ **Inlet ring:** with pressure tap (k-factor: 76)
- ⑤ **Mounting holes:** for FlowGrid

Pin assignment: (see connection diagram)

B VBS0250PSPGS R3G250PR1711 (EC centrifugal fan)

Dimensions in mm

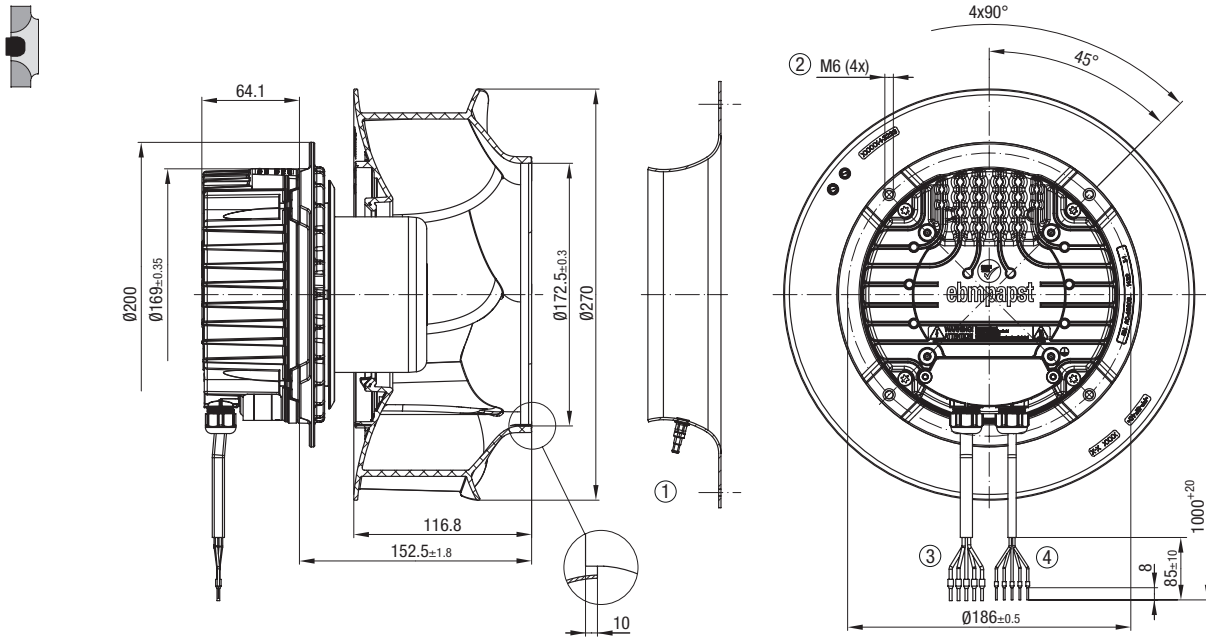

- ① **Accessory part:** Inlet ring 96355-2-4013 with pressure tap (k-factor: 76) not included in scope of delivery (Dimensions: see "Accessories" chapter)
- ② **Max. clearance of screw:** 16 mm
- ③ **Cable:** PVC AWG18, 5x crimped ferrules
- ④ **Cable:** PVC AWG22, 5x crimped ferrules

Pin assignment: (see connection diagram)

Installation position: Shaft horizontal or rotor on bottom, rotor on top on request

B VBH0250PSPGS K3G250PR1712 (EC centrifugal module with support bracket)

Dimensions in mm

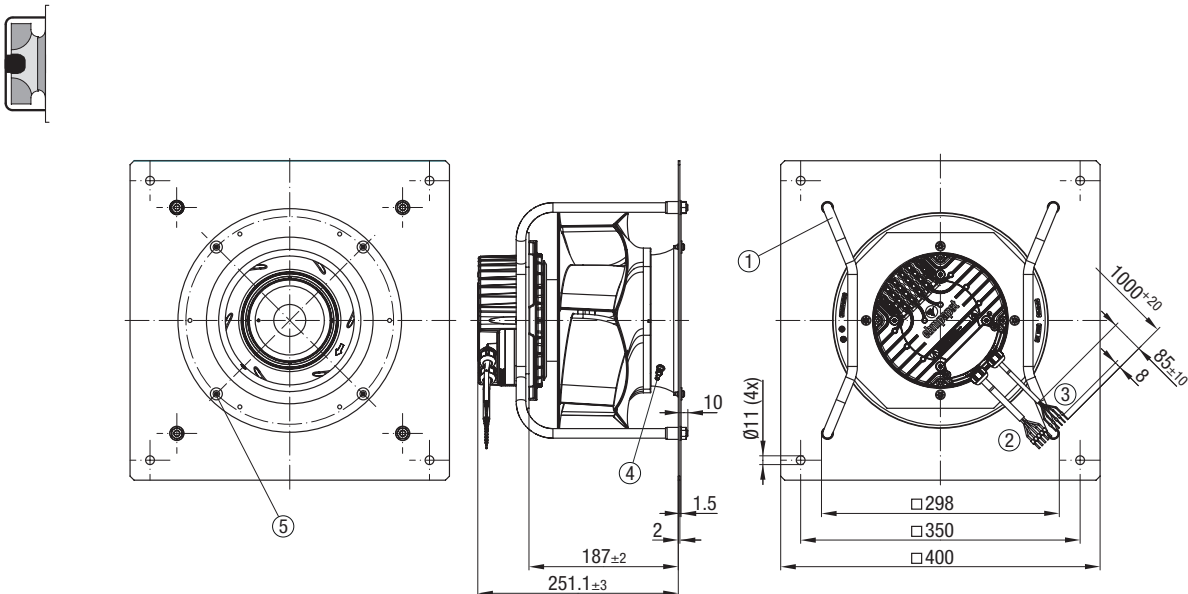

- ① **Installation position:** Shaft horizontal (Install support struts only vertically according to view!) or rotor on bottom, rotor on top on request
- ② **Cable:** PVC AWG18, 5x crimped ferrules
- ③ **Cable:** PVC AWG22, 5x crimped ferrules
- ④ **Inlet ring:** with pressure tap (k-factor: 76)
- ⑤ **Mounting holes:** for FlowGrid

Pin assignment: (see connection diagram)

C VBS0250PTPGS R3G250PR02J1 (EC centrifugal fan)

Dimensions in mm

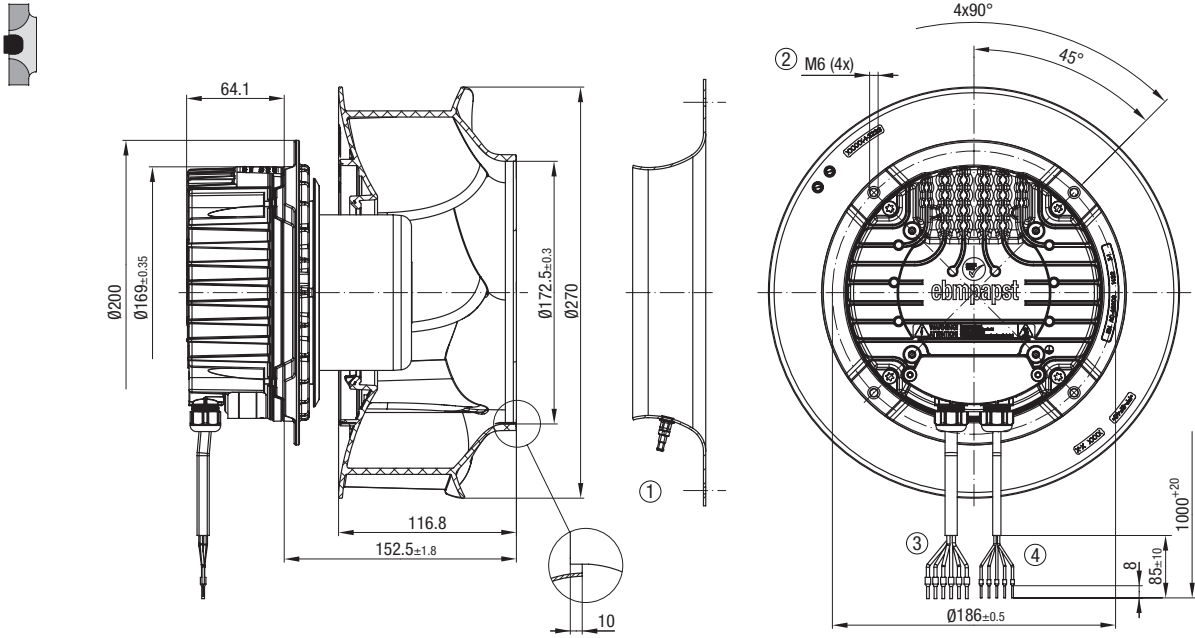

- ① **Accessory part:** Inlet ring 96355-2-4013 with pressure tap (k-factor: 76) not included in scope of delivery (Dimensions: see "Accessories" chapter)
- ② **Max. clearance of screw:** 16 mm
- ③ **Cable:** PVC AWG18, 6x crimped ferrules
- ④ **Cable:** PVC AWG22, 5x crimped ferrules

Pin assignment: (see connection diagram)

Installation position: Shaft horizontal or rotor on bottom, rotor on top on request

C VBH0250PTPGS K3G250PR02J2 (EC centrifugal module with support bracket)

Dimensions in mm

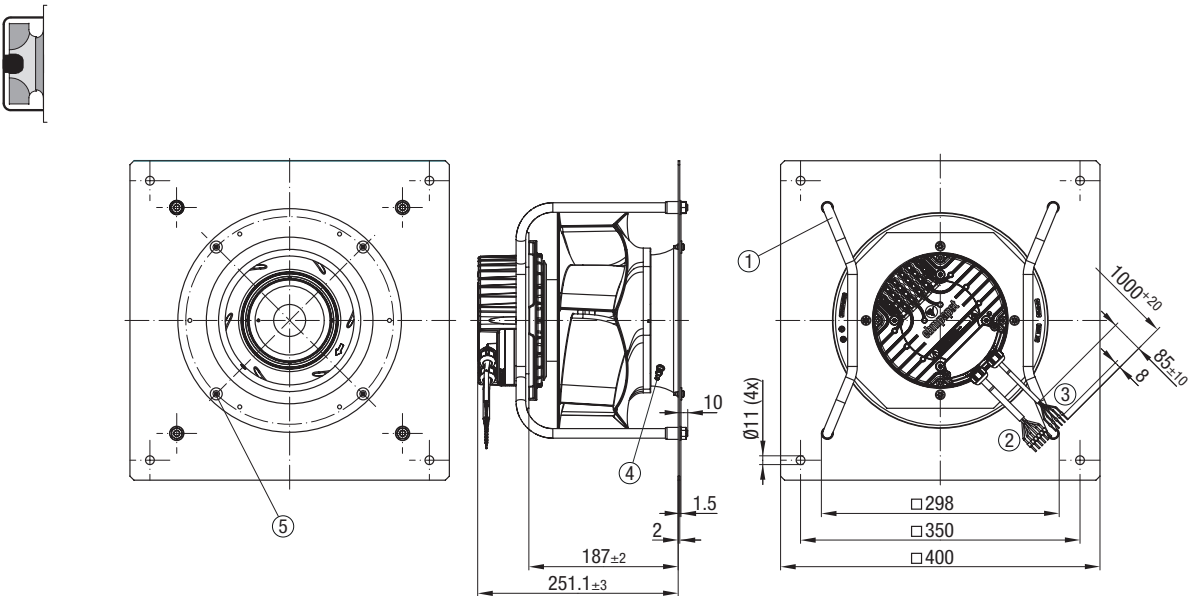

- ① **Installation position:** Shaft horizontal (Install support struts only vertically according to view!) or rotor on bottom, rotor on top on request
- ② **Cable:** PVC AWG18, 6x crimped ferrules
- ③ **Cable:** PVC AWG22, 5x crimped ferrules
- ④ **Inlet ring:** with pressure tap (k-factor: 76)
- ⑤ **Mounting holes:** for FlowGrid

Pin assignment: (see connection diagram)

RadiPac 280

EC centrifugal fans, backward curved



Material/surface

- Support bracket: Steel, painted black
- Support plate: Sheet steel, galvanized
- Inlet ring: Sheet steel, galvanized
- Impeller: PP plastic
- Rotor: Painted black
- Electronics housing: Die-cast aluminum

Mechanical characteristics

- Number of blades: 6
- Direction of rotation: Clockwise viewed toward rotor
- Installation position: See product drawing
- Condensation drainage holes: Rotor side
- Mode: Continuous operation (S1)
- Mounting: Maintenance-free ball bearings

Further Information





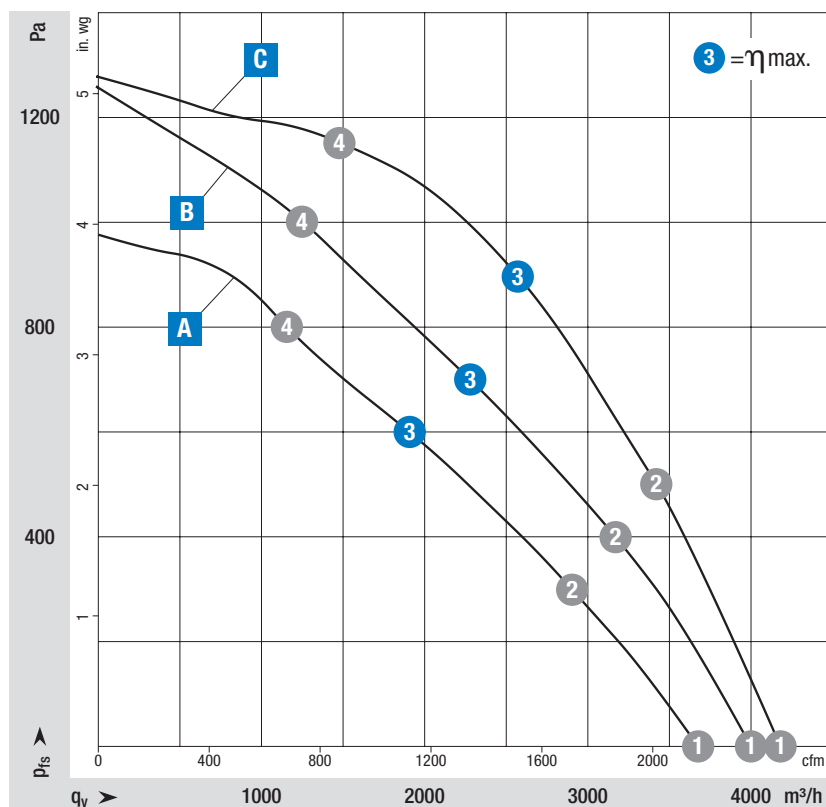



- Information about touch current, electrical connection, degree of protection, insulation class, environmental protection class, EMC standards as well as standards and approvals can be found in the product-specific data sheets.

on Page 34	Drawings
on Page 154	Accessories
on Page 166	Connection diagrams and technical features
on Page 172	Technical parameters & scope
More at	www.ebmpapst.com/worldwide www.ebmpapst.com/radipac



Measuring requirements

Air performance measured according to: ISO 5801, installation category A, with ebm-papst inlet ring without contact protection. Intake-side sound level: L_{pA} according to 13347, L_{pA} measured at 1 m distance from fan axis. The values given are only applicable under the specified measuring conditions and may differ depending on the installation conditions. In the event of deviation from the standard configuration, the parameters must be checked in installed condition.

Curve				Operating point	Nominal voltage	Speed n	Max. Input power P_{ed}	Max. Input current I	Sound power level LWA	Perm. ambient temp.	Degree of protection	Conn. diagram	
Nominal voltage range 1-200-277 V AC, 50/60 Hz				VAC	rpm	W	A	dB(A)	°C				
Type	Part number	Fan type											
A	VBS0280PSPGS	R3G280PR03H1	Centrifugal fan		①	230	2990	500	2,18	85	-25..+45	IP 55	RP2)
					②	230	2785	500	2,30	79			
	③	230	2670	500	2,30	72							
	④	230	2835	500	2,30	77							
	VBH0280PSPGS	K3G280PR03H2	Support bracket										
B	VBS0280PSPGS	R3G280PR04I1	Centrifugal fan		①	230	3260	640	2,81	87	-25..+45	IP 55	RP2)
					②	230	3115	730	3,18	82			
	③	230	3000	750	3,30	77							
	④	230	3180	720	3,15	82							
	VBH0280PSPGS	K3G280PR04I2	Support bracket										
Nominal voltage range 3-380-480 V AC, 50/60 Hz				VAC	rpm	W	A	dB(A)	°C				
Type	Part number	Fan type											
C	VBS0280PTPKS	R3G280PS10J1	Centrifugal fan		①	400	3400	740	1,17	88	-25..+45	IP 55	RP3)
					②	400	3400	960	1,49	83			
	③	400	3400	1050	1,60	80							
	④	400	3400	930	1,43	85							
	VBH0280PTPKS	K3G280PS10J2	Support bracket										

Subject to change

Values set in blue are nominal data at operating point with maximum load.

RadiPac 280

A VBS0280PSPGS R3G280PR03H1 (EC centrifugal fan)

Dimensions in mm

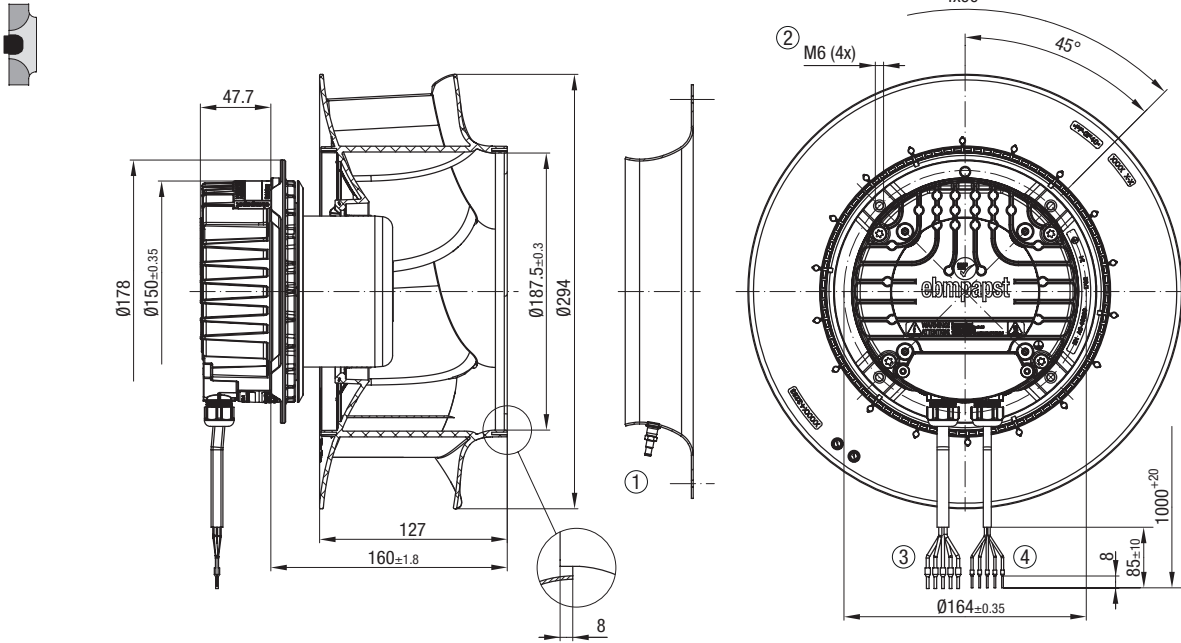

- ① **Accessory part:** Inlet ring 28004-2-4013 with pressure tap (k-factor: 77) not included in scope of delivery (Dimensions: see "Accessories" chapter)
- ② **Max. clearance of screw:** 16 mm
- ③ **Cable:** PVC AWG18, 5x crimped ferrules
- ④ **Cable:** PVC AWG22, 5x crimped ferrules

Pin assignment: (see connection diagram)

Installation position: Shaft horizontal or rotor on bottom, rotor on top on request

A VBH0280PSPGS K3G280PR03H2 (EC centrifugal module with support bracket)

Dimensions in mm

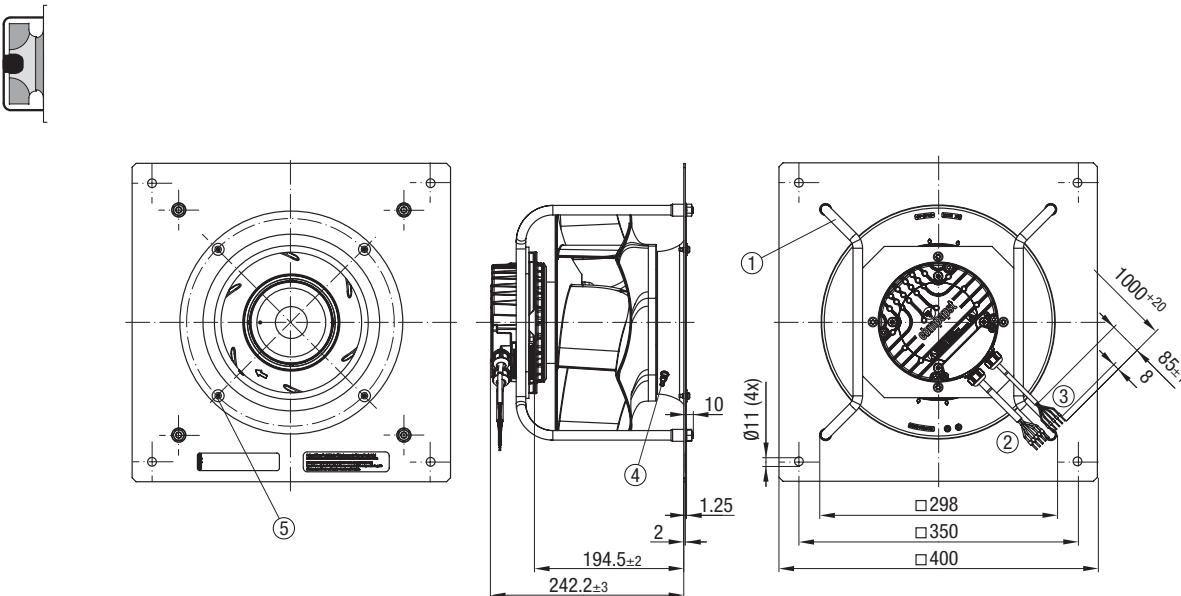

- ① **Installation position:** Shaft horizontal (Install support struts only vertically according to view!) or rotor on bottom, rotor on top on request
- ② **Cable:** PVC AWG18, 5x crimped ferrules
- ③ **Cable:** PVC AWG22, 5x crimped ferrules
- ④ **Inlet ring:** with pressure tap (k-factor: 77)
- ⑤ **Mounting holes:** for FlowGrid

Pin assignment: (see connection diagram)

B VBS0280PSPGS R3G280PR04I1 (EC centrifugal fan)

Dimensions in mm

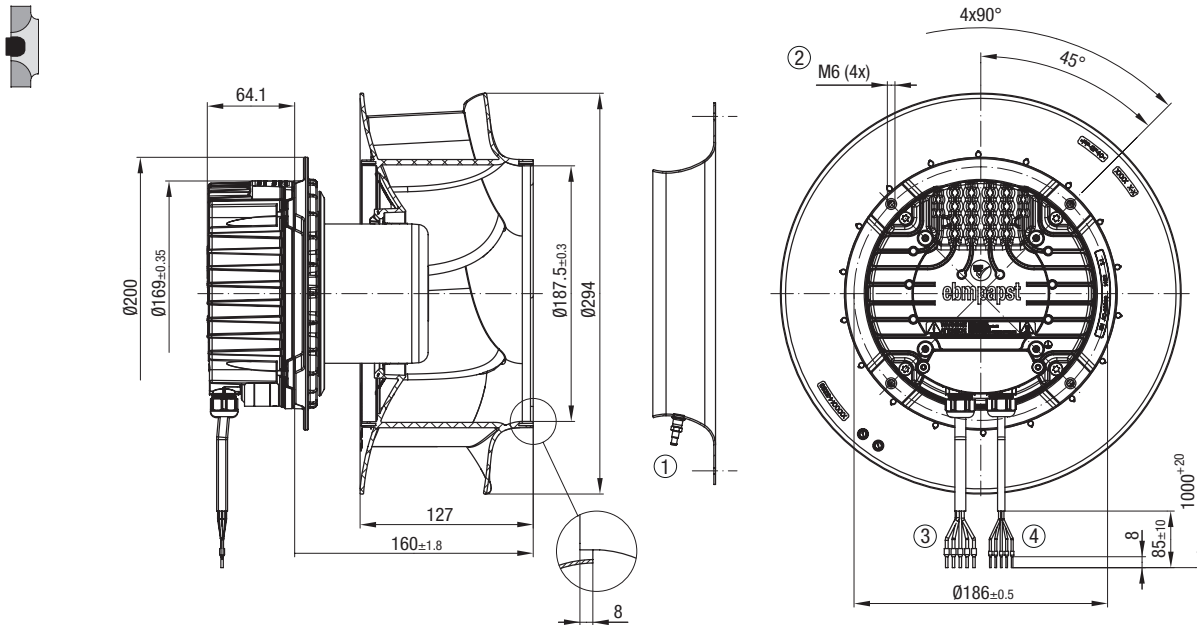

- ① **Accessory part:** Inlet ring 28004-2-4013 with pressure tap (k-factor: 77) not included in scope of delivery (Dimensions: see "Accessories" chapter)
- ② **Max. clearance of screw:** 16 mm
- ③ **Cable:** PVC AWG18, 5x crimped ferrules
- ④ **Cable:** PVC AWG22, 5x crimped ferrules

Pin assignment: (see connection diagram)

Installation position: Shaft horizontal or rotor on bottom, rotor on top on request

B VBH0280PSPGS K3G280PR04I2 (EC centrifugal module with support bracket)

Dimensions in mm

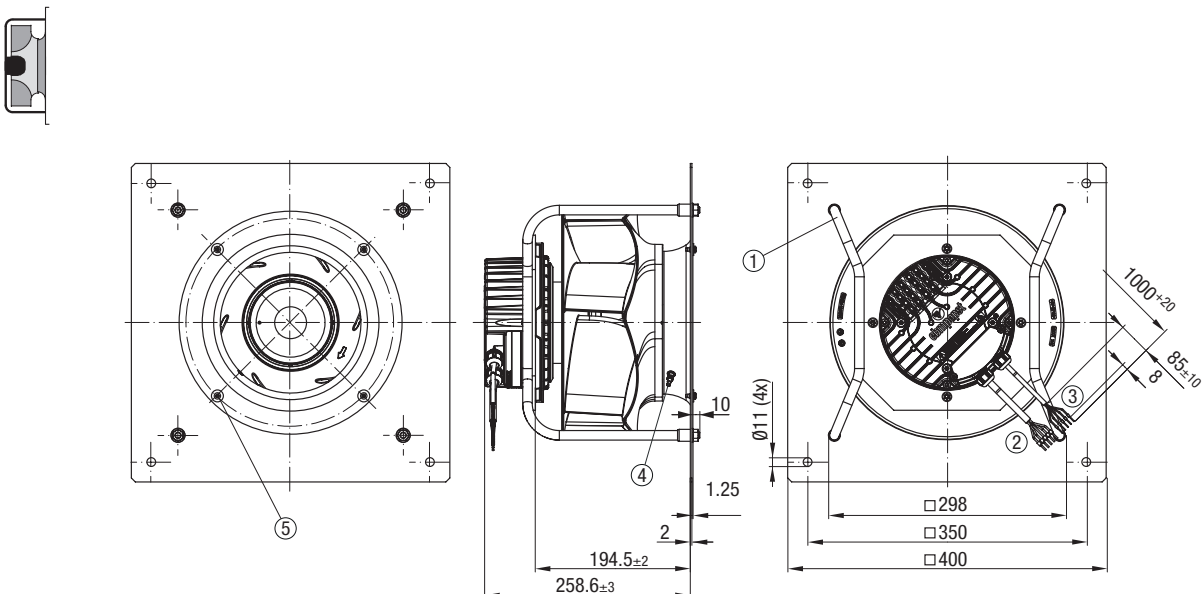

- ① **Installation position:** Shaft horizontal (Install support struts only vertically according to view!) or rotor on bottom, rotor on top on request
- ② **Cable:** PVC AWG18, 5x crimped ferrules
- ③ **Cable:** PVC AWG22, 5x crimped ferrules
- ④ **Inlet ring:** with pressure tap (k-factor: 77)
- ⑤ **Mounting holes:** for FlowGrid

Pin assignment: (see connection diagram)

RadiPac 280

C VBS0280PTPKS R3G280PS10J1 (EC centrifugal fan)

Dimensions in mm

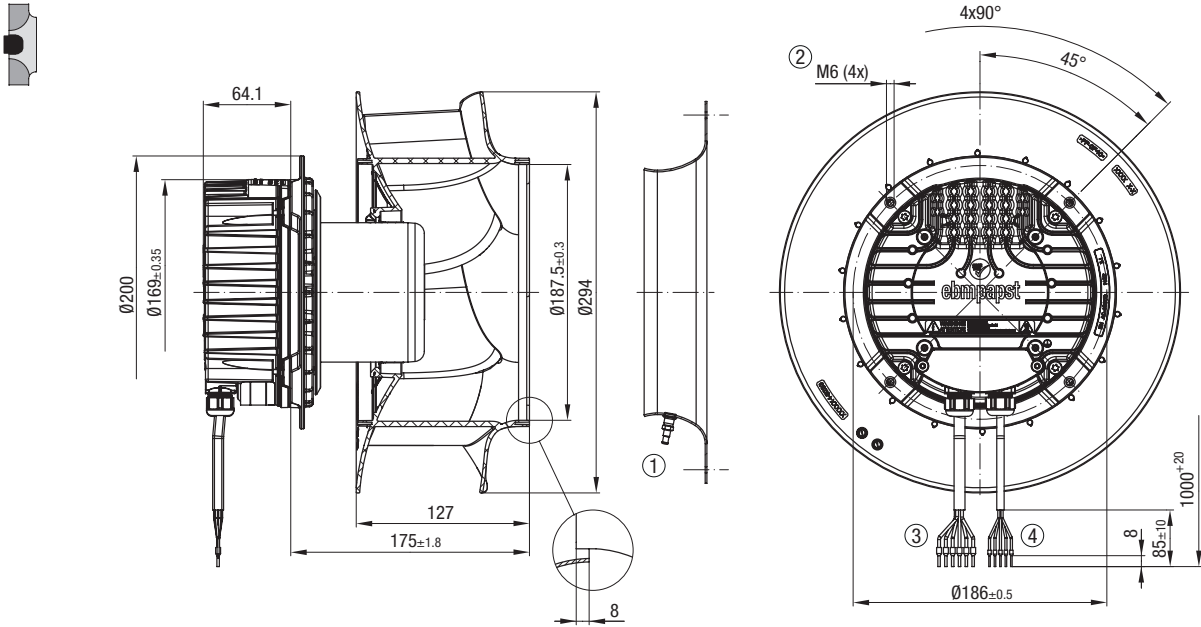

- ① **Accessory part:** Inlet ring 28004-2-4013 with pressure tap (k-factor: 77) not included in scope of delivery (Dimensions: see "Accessories" chapter)
- ② **Max. clearance of screw:** 16 mm
- ③ **Cable:** PVC AWG18, 6x crimped ferrules
- ④ **Cable:** PVC AWG22, 5x crimped ferrules

Pin assignment: (see connection diagram)
Installation position: Shaft horizontal or rotor on bottom, rotor on top on request

C VBH0280PTPKS K3G280PS10J2 (EC centrifugal module with support bracket)

Dimensions in mm

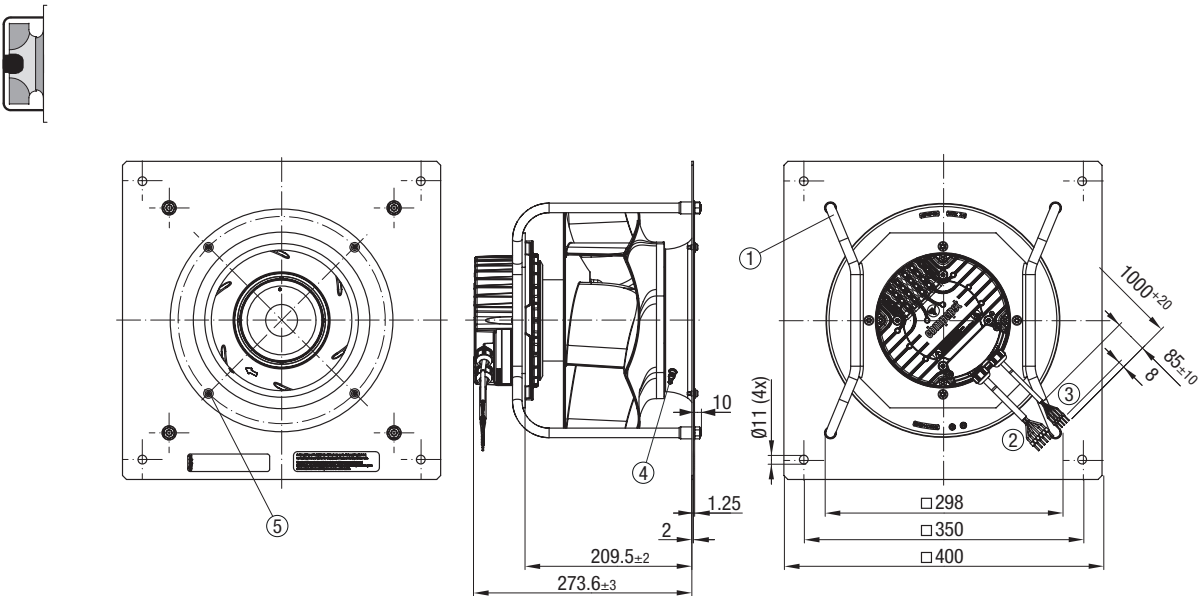

- ① **Installation position:** Shaft horizontal (Install support struts only vertically according to view!) or rotor on bottom, rotor on top on request
- ② **Cable:** PVC AWG18, 6x crimped ferrules
- ③ **Cable:** PVC AWG22, 5x crimped ferrules
- ④ **Inlet ring:** with pressure tap (k-factor: 77)
- ⑤ **Mounting holes:** for FlowGrid

Pin assignment: (see connection diagram)

RadiPac 310

EC centrifugal fans, backward curved



Material/surface

- Support bracket: Steel, painted black
- Support plate: Sheet steel, galvanized
- Inlet ring: Sheet steel, galvanized
- Impeller: Sheet aluminum
- Rotor: Painted black
- Electronics housing: Die-cast aluminum

Mechanical characteristics

- Number of blades: 5
- Direction of rotation: Clockwise viewed toward rotor
- Installation position: See product drawing
- Condensation drainage holes: Rotor side
- Mode: Continuous operation (S1)
- Mounting: Maintenance-free ball bearings

Further Information





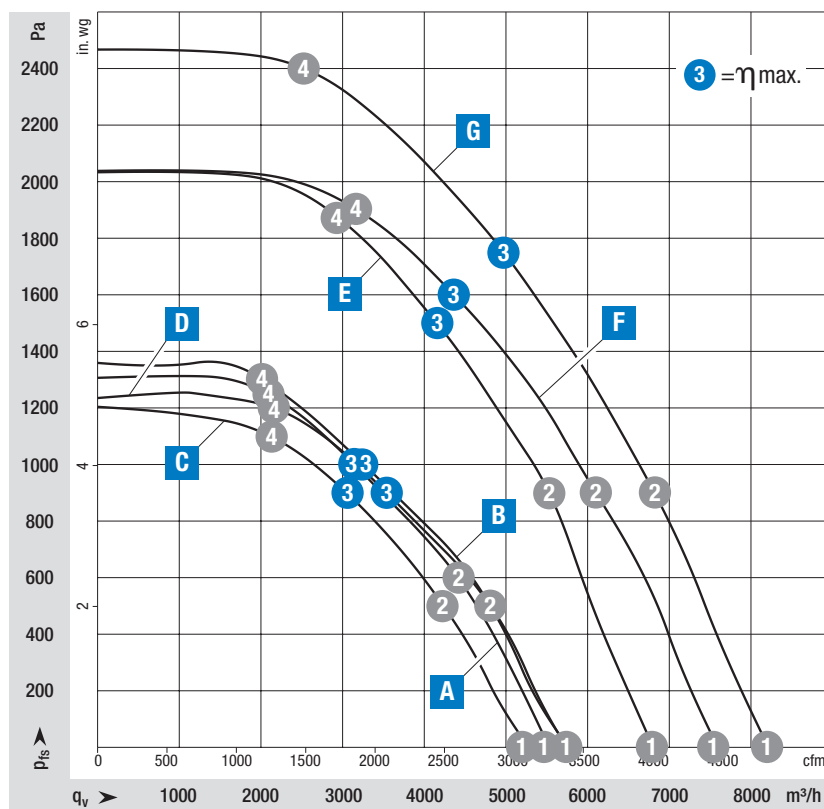











- Information about touch current, electrical connection, degree of protection, insulation class, environmental protection class, EMC standards as well as standards and approvals can be found in the product-specific data sheets.

on Page 40	Drawings
on Page 154	Accessories
on Page 166	Connection diagrams and technical features
on Page 172	Technical parameters & scope
More at	www.ebmpapst.com/worldwide www.ebmpapst.com/radipac



Measuring requirements

Air performance measured according to: ISO 5801, installation category A, with ebm-papst inlet ring without contact protection. Intake-side sound level: L_{wA} according to 13347, L_{wA} measured at 1 m distance from fan axis. The values given are only applicable under the specified measuring conditions and may differ depending on the installation conditions. In the event of deviation from the standard configuration, the parameters must be checked in installed condition.

Curve				Operating point	Nominal voltage	Speed n	Max. Input power P _{id}	Max. Input current I	Sound power level L _{WA}	Perm. ambient temp.	Degree of protection	Conn. diagram
Nominal voltage range 1-200-277 V AC, 50/60 Hz				VAC	rpm	W	A	dB(A)	°C			
Type	Part number	Fan type		1	2	3	4	1	2	3	4	
A	VBS0310PSRHS	R3G310PG5721	Centrifugal fan		230	3200	875	3,80	93	-25..+45	IP 54	RP6)
	VBH0310PSRHS	K3G310PG5728	Support bracket		230	3200	1380	6,01	84			
				230	3200	1500	6,50	82				
				230	3200	1450	6,32	85				
B	VBS0310PSRHS	R3G310PG9321	Centrifugal fan		230	3200	1035	4,51	95	-25..+55	IP 54	RP6)
	VBH0310PSRHS	K3G310PG9321	Support bracket		230	3200	1375	6,00	88			
				230	3200	1500	6,60	81				
				230	3200	1490	6,50	86				
Nominal voltage range 3-380-480 V AC, 50/60 Hz				VAC	rpm	W	A	dB(A)	°C			
Type	Part number	Fan type		1	2	3	4	1	2	3	4	
C	VBS0310PTPMS	R3G310PT08J1	Centrifugal fan		400	3010	670	1,06	95	-25..+40	IP 55	RP3)
	VBH0310PTPMS	K3G310PT08J2	Support bracket		400	3010	1050	1,61	84			
				400	3010	1230	1,90	78				
				400	3010	1190	1,82	85				
D	VBS0310PTPMS	R3G310PT10W1	Centrifugal fan		400	3140	900	1,40	93	-40..+40	IP 55	RP3)
	VBH0310PTPMS	K3G310PT10W1	Support bracket		400	3140	1240	1,90	86			
				400	3140	1370	2,10	81				
				400	3140	1315	2,01	84				
E	VBS0310PTRLS	R3G310PV6903	Centrifugal fan		400	4000	2200	3,44	105	-40..+40	IP 55	RP4)
	VBH0310PTRLS	K3G310PV6903	Support bracket		400	4000	2855	4,41	93			
				400	4000	3050	4,70	89				
				400	4000	2995	4,61	90				
F	VBS0310PTRLS	R3G310PV6902	Centrifugal fan		400	4000	1760	2,79	103	-40..+40	IP 55	RP4)
	---	---	Support bracket		400	4000	2640	4,08	91			
				400	4000	3000	4,70	86				
				400	4000	2865	4,42	91				
F	VBS0310PTRLS	R3G310PV7304	Centrifugal fan		400	4400	2495	3,86	106	-40..+50	IP 20	RP4)
	---	---	Support bracket		400	4400	3475	5,32	101			
				400	4400	4100	6,30	90				
				400	4400	3650	5,58	96				

Subject to change

Values set in blue are nominal data at operating point with maximum load.

RadiPac 310

A VBS0310PSRHS R3G310PG5721 (EC centrifugal fan)

Dimensions in mm

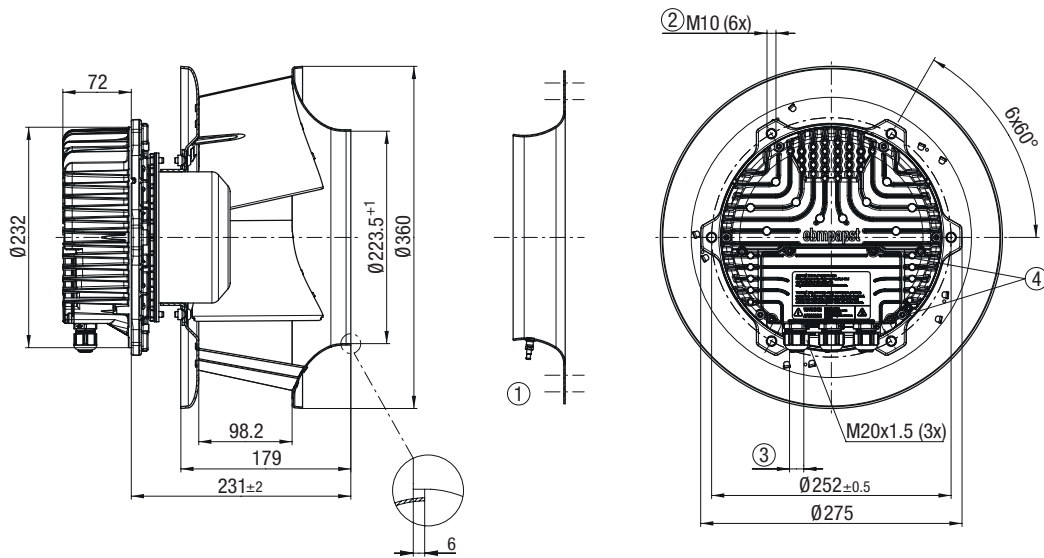

- ① **Accessory part:** Inlet ring 31475-2-4013 with pressure tap (k-factor: 116) not included in scope of delivery (Dimensions: see "Accessories" chapter)
- ② **Max. clearance of screw:** 16 mm
- ③ **Cable gland M20 x 1.5:** Cable diameter min. 4 mm, max. 10 mm, Tightening torque 4 ± 0.6 Nm
- ④ **Tightening torque:** 3.5 ± 0.5 Nm

Pin assignment: (see connection diagram)

Installation position: Shaft horizontal or rotor on bottom, rotor on top on request

A VBH0310PSRHS K3G310PG5728 (EC centrifugal module with support bracket)

Dimensions in mm

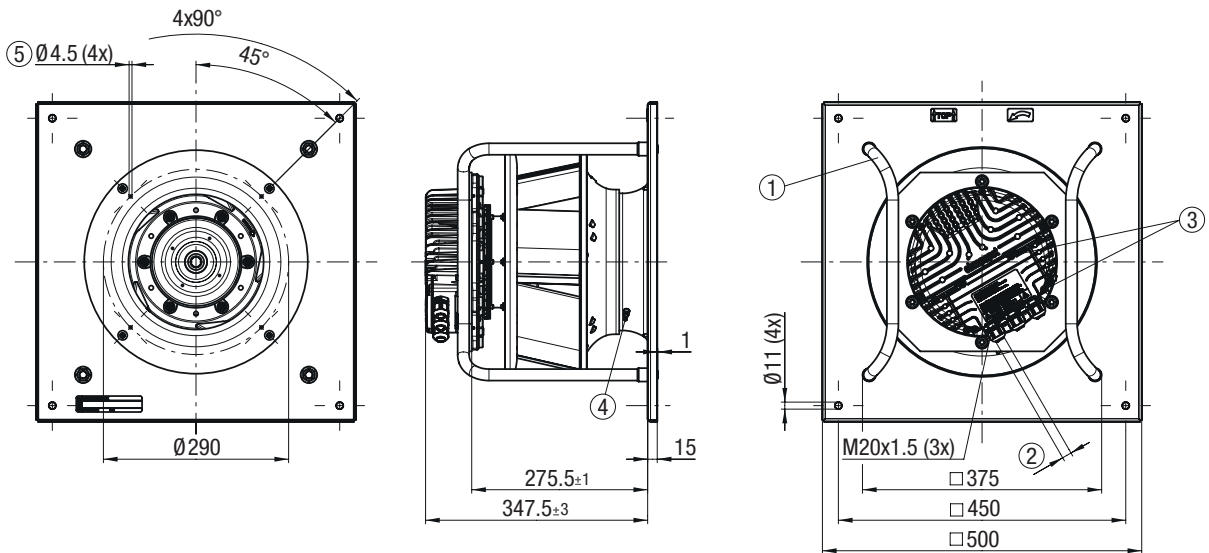

- ① **Installation position:** Shaft horizontal (Install support struts only vertically according to view!) or rotor on bottom, rotor on top on request
- ② **Cable gland M20 x 1.5:** Cable diameter min. 4 mm, max. 10 mm, Tightening torque 4 ± 0.6 Nm
- ③ **Tightening torque:** 3.5 ± 0.5 Nm
- ④ **Inlet ring:** with pressure tap (k-factor: 116)
- ⑤ **Mounting holes:** for FlowGrid

Pin assignment: (see connection diagram)

B VBS0310PSRHS R3G310PG9321 (EC centrifugal fan)

Dimensions in mm

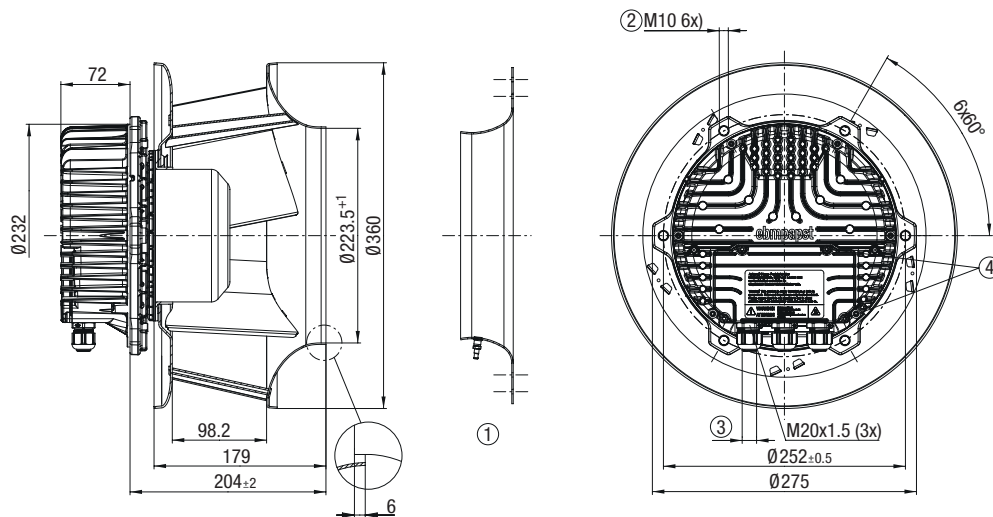

- ① **Accessory part:** Inlet ring 31475-2-4013 with pressure tap (k-factor: 116) not included in scope of delivery (Dimensions: see "Accessories" chapter)
- ② **Max. clearance of screw:** 16 mm
- ③ **Cable gland M20 x 1.5:** Cable diameter min. 4 mm, max. 10 mm, Tightening torque 4 ± 0.6 Nm
- ④ **Tightening torque:** 3.5 ± 0.5 Nm

Pin assignment: (see connection diagram)

Installation position: Shaft horizontal or rotor on bottom, rotor on top on request

B VBH0310PSRHS K3G310PG9321 (EC centrifugal module with support bracket)

Dimensions in mm

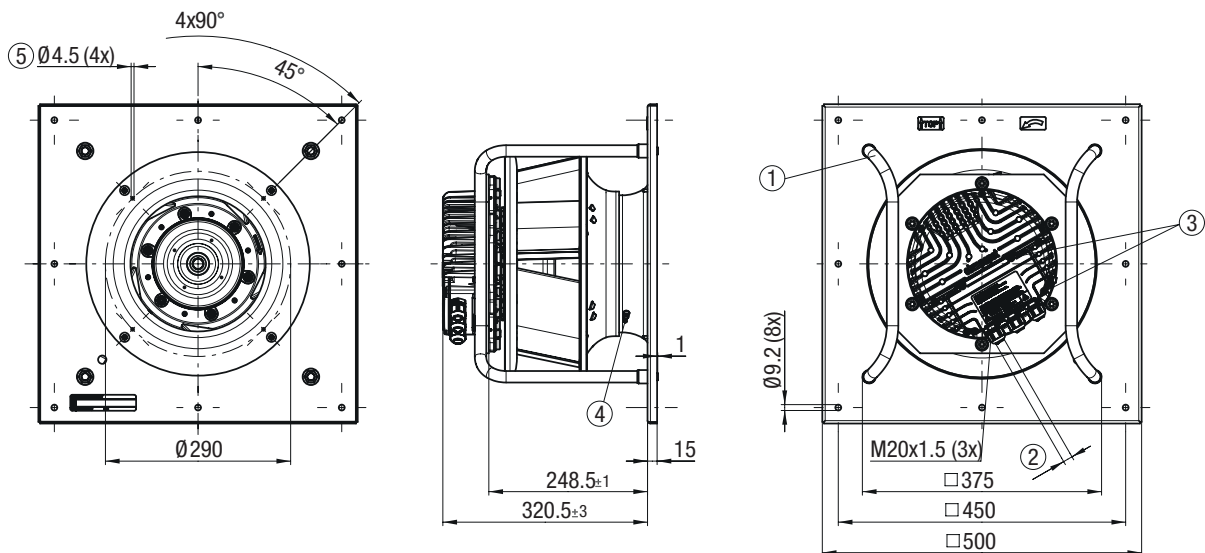

- ① **Installation position:** Shaft horizontal (Install support struts only vertically according to view!) or rotor on bottom, rotor on top on request
- ② **Cable gland M20 x 1.5:** Cable diameter min. 4 mm, max. 10 mm, Tightening torque 4 ± 0.6 Nm
- ③ **Tightening torque:** 3.5 ± 0.5 Nm
- ④ **Inlet ring:** with pressure tap (k-factor: 116)
- ⑤ **Mounting holes:** for FlowGrid

Pin assignment: (see connection diagram)

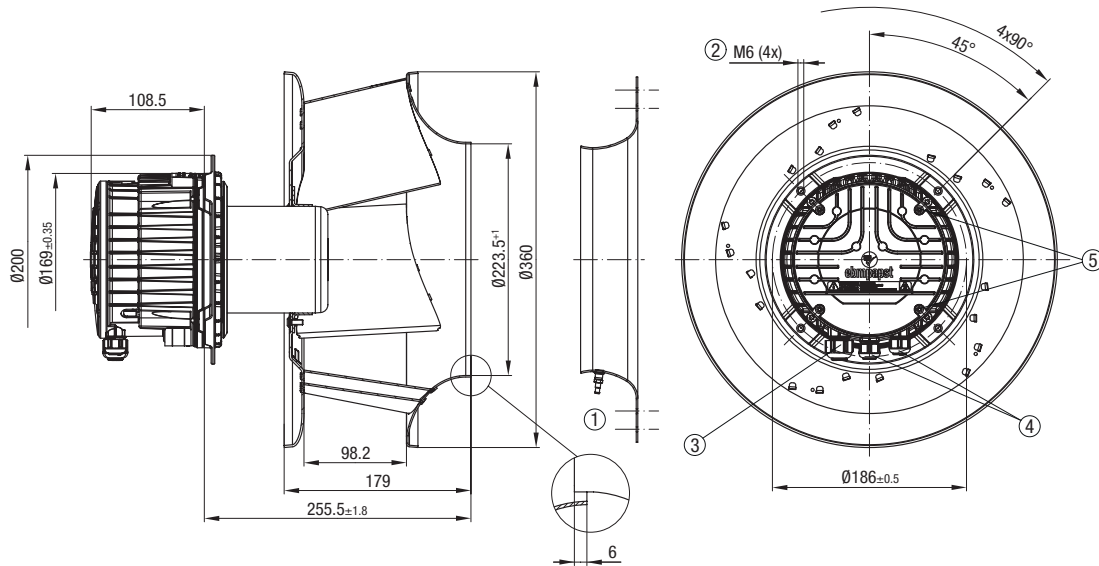

- ① **Accessory part:** Inlet ring 31475-2-4013 with pressure tap (k-factor: 116) not included in scope of delivery (Dimensions: see "Accessories" chapter)
- ② **Max. clearance of screw:** 16 mm
- ③ **Cable gland M20 x 1.5:** Cable diameter min. 8 mm, max. 12 mm, Tightening torque 1.8 ± 0.3 Nm (use must be made of seal provided)
Cable diameter min. 4 mm, max. 10 mm, Tightening torque 1.8 ± 0.3 Nm
- ④ **Cable gland M16 x 1.5 (2x):** Cable diameter min. 6 mm, max. 10 mm, Tightening torque 1.8 ± 0.3 Nm (use must be made of seal provided)
Cable diameter min. 4 mm, max. 7 mm, Tightening torque 1.8 ± 0.3 Nm
- ⑤ **Tightening torque:** 1.5 ± 0.2 Nm

Pin assignment: (see connection diagram)
Installation position: Shaft horizontal or rotor on bottom, rotor on top on request

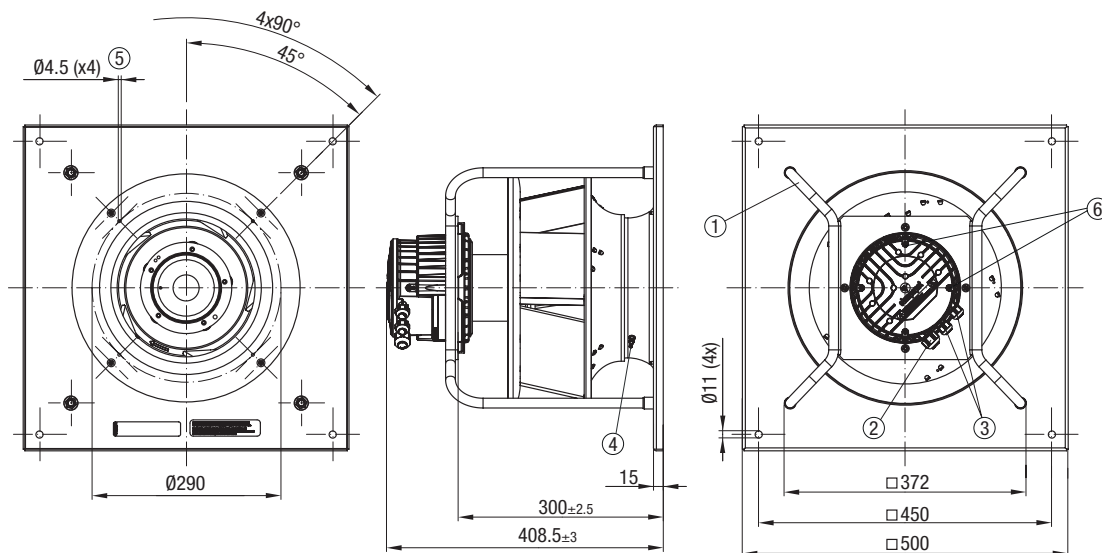

- ① **Installation position:** Shaft horizontal (Install support struts only vertically according to view!) or rotor on bottom, rotor on top on request
- ② **Cable gland M20 x 1.5:** Cable diameter min. 8 mm, max. 12 mm, Tightening torque 1.8 ± 0.3 Nm (use must be made of seal provided)
Cable diameter min. 4 mm, max. 10 mm, Tightening torque 1.8 ± 0.3 Nm
- ③ **Cable gland M16 x 1.5 (2x):** Cable diameter min. 6 mm, max. 10 mm, Tightening torque 1.8 ± 0.3 Nm (use must be made of seal provided)
Cable diameter min. 4 mm, max. 7 mm, Tightening torque 1.8 ± 0.3 Nm
- ④ **Inlet ring:** with pressure tap (k-factor: 116)
- ⑤ **Mounting holes:** for FlowGrid
- ⑥ **Tightening torque:** 1.5 ± 0.2 Nm

Pin assignment: (see connection diagram)

D VBS0310PTPMS R3G310PT10W1 (EC centrifugal fan)

Dimensions in mm

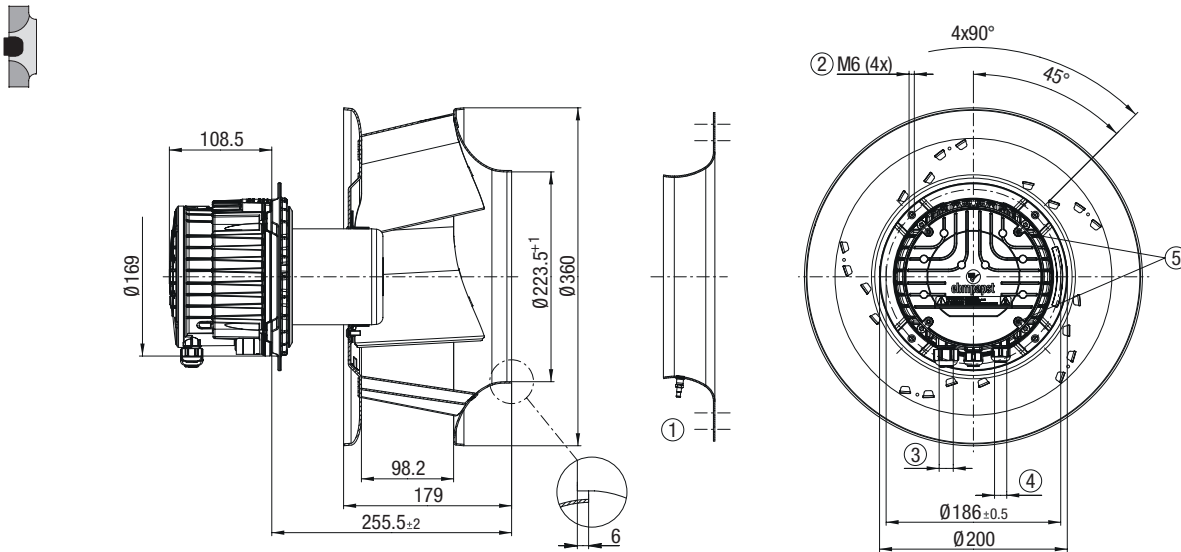

- ① **Accessory part:** Inlet ring 31475-2-4013 with pressure tap (k-factor: 116) not included in scope of delivery (Dimensions: see "Accessories" chapter)
- ② **Max. clearance of screw:** 16 mm
- ③ **Cable gland M20 x 1.5:** Cable diameter min. 8 mm, max. 12 mm, Tightening torque 1.8 ± 0.3 Nm (use must be made of seal provided)
Cable diameter min. 4 mm, max. 10 mm, Tightening torque 1.8 ± 0.3 Nm
- ④ **Cable gland M16 x 1.5 (2x):** Cable diameter min. 6 mm, max. 10 mm, Tightening torque 1.8 ± 0.3 Nm (use must be made of seal provided)
Cable diameter min. 4 mm, max. 7 mm, Tightening torque 1.8 ± 0.3 Nm
- ⑤ **Tightening torque:** 1.5 ± 0.2 Nm

Pin assignment: (see connection diagram)

Installation position: Shaft horizontal or rotor on bottom, rotor on top on request

D VBH0310PTPMS K3G310PT10W1 (EC centrifugal module with support bracket)

Dimensions in mm

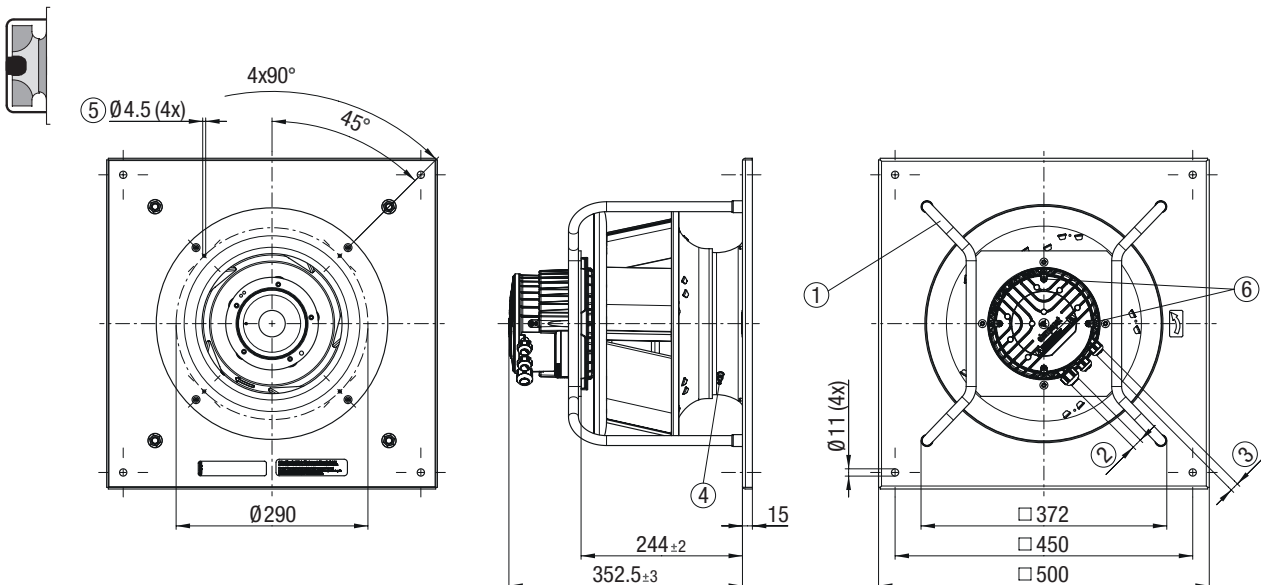

- ① **Installation position:** Shaft horizontal (Install support struts only vertically according to view!) or rotor on bottom, rotor on top on request
- ② **Cable gland M20 x 1.5:** Cable diameter min. 8 mm, max. 12 mm, Tightening torque 1.8 ± 0.3 Nm (use must be made of seal provided)
Cable diameter min. 4 mm, max. 10 mm, Tightening torque 1.8 ± 0.3 Nm
- ③ **Cable gland M16 x 1.5 (2x):** Cable diameter min. 6 mm, max. 10 mm, Tightening torque 1.8 ± 0.3 Nm (use must be made of seal provided)
Cable diameter min. 4 mm, max. 7 mm, Tightening torque 1.8 ± 0.3 Nm
- ④ **Inlet ring:** with pressure tap (k-factor: 116)
- ⑤ **Mounting holes:** for FlowGrid
- ⑥ **Tightening torque:** 1.5 ± 0.2 Nm

Pin assignment: (see connection diagram)

RadiPac 310

E VBS0310PTRLS R3G310PV6903 (EC centrifugal fan)

Dimensions in mm

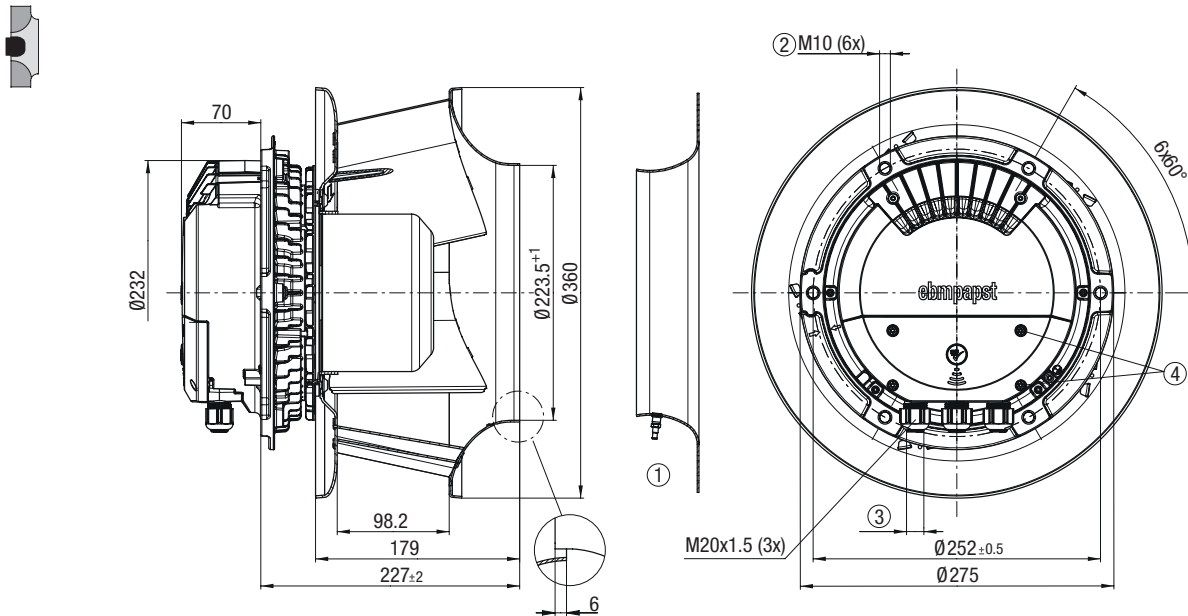

- ① **Accessory part:** Inlet ring 31475-2-4013 with pressure tap (k-factor: 116) not included in scope of delivery (Dimensions: see "Accessories" chapter)
- ② **Max. clearance of screw:** 20 mm
- ③ **Cable gland M20 x 1.5:** Cable diameter min. 4 mm, max. 10 mm, Tightening torque 4 ± 0.6 Nm
- ④ **Tightening torque:** 1.5 ± 0.2 Nm

Pin assignment: (see connection diagram)

Installation position: Shaft horizontal or rotor on bottom, rotor on top on request

E VBH0310PTRLS K3G310PV6903 (EC centrifugal module with support bracket)

Dimensions in mm

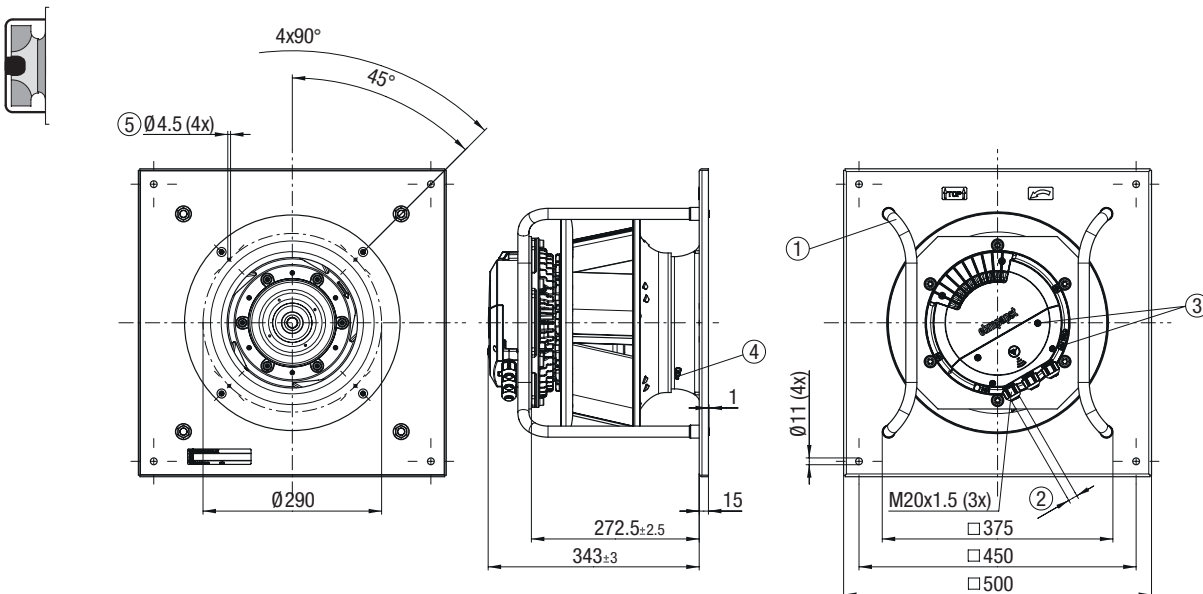

- ① **Installation position:** Shaft horizontal (Install support struts only vertically according to view!) or rotor on bottom, rotor on top on request
- ② **Cable gland M20 x 1.5:** Cable diameter min. 4 mm, max. 10 mm, Tightening torque 4 ± 0.6 Nm
- ③ **Tightening torque:** 1.5 ± 0.2 Nm
- ④ **Inlet ring:** with pressure tap (k-factor: 116)
- ⑤ **Mounting holes:** for FlowGrid

Pin assignment: (see connection diagram)

F VBS0310PTRLS R3G310PV6902 (EC centrifugal fan)

Dimensions in mm

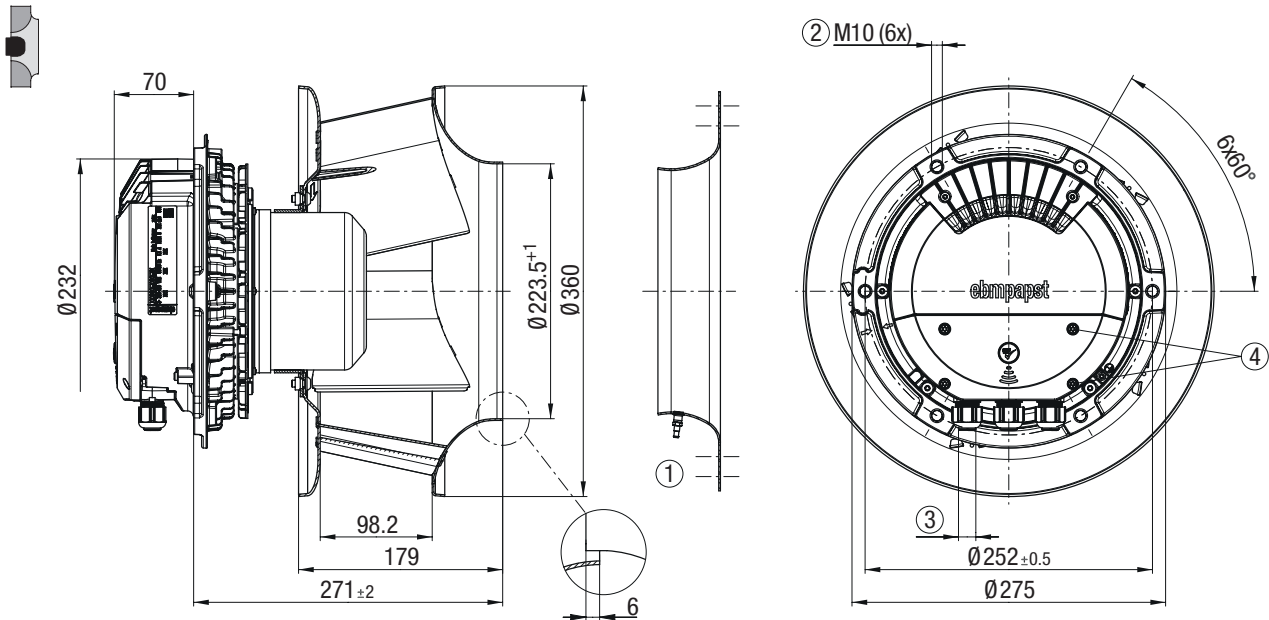

- ① Accessory part: Inlet ring 31475-2-4013 with pressure tap (k-factor: 116) not included in scope of delivery (Dimensions: see "Accessories" chapter)
- ② Max. clearance of screw: 20 mm
- ③ Cable gland M20 x 1.5: Cable diameter min. 4 mm, max. 10 mm, Tightening torque 4 ± 0.6 Nm
- ④ Tightening torque: 1.5 ± 0.2 Nm

Pin assignment: (see connection diagram)

Installation position: Shaft horizontal or rotor on bottom, rotor on top on request

G VBS0310PTRLS R3G310PV7304 (EC centrifugal fan)

Dimensions in mm

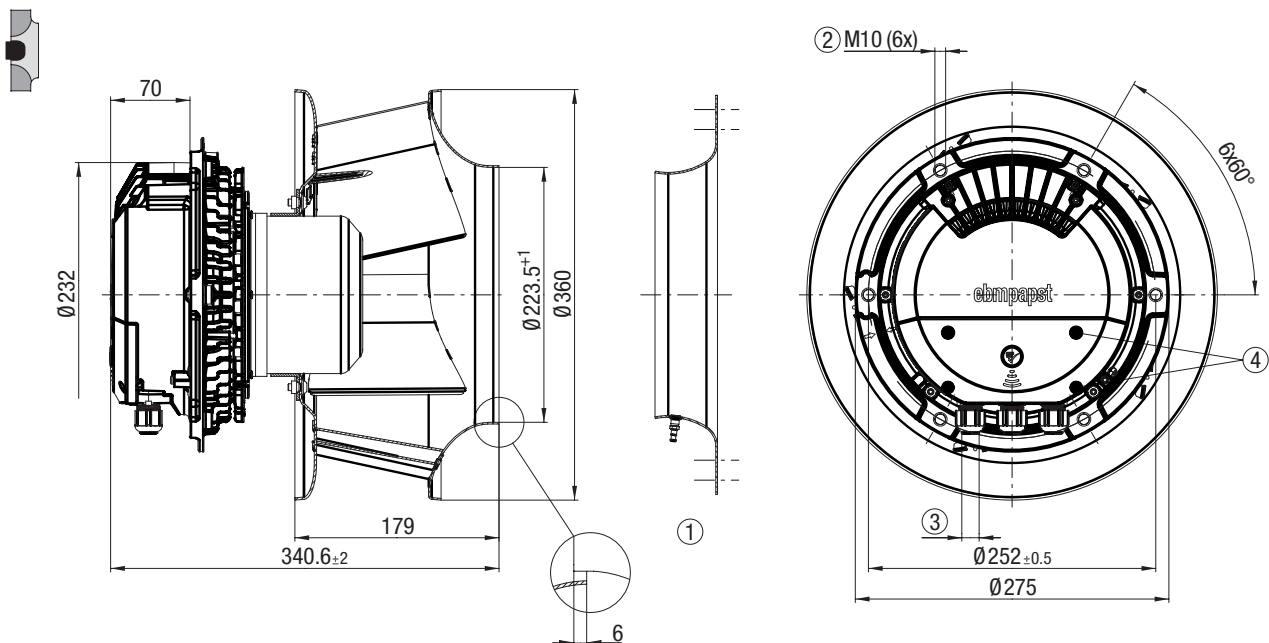

- ① Accessory part: Inlet ring 31475-2-4013 with pressure tap (k-factor: 116) not included in scope of delivery (Dimensions: see "Accessories" chapter)
- ② Max. clearance of screw: 20 mm
- ③ Cable gland M20 x 1.5: Cable diameter min. 4 mm, max. 10 mm, Tightening torque 4 ± 0.6 Nm
- ④ Tightening torque: 1.5 ± 0.2 Nm

Pin assignment: (see connection diagram)

Installation position: Shaft horizontal or rotor on bottom, rotor on top on request

RadiPac 355

EC centrifugal fans, backward curved



Material/surface

- Support bracket: Steel, painted black
- Support plate: Sheet steel, galvanized
- Inlet ring: Sheet steel, galvanized
- Impeller: Sheet aluminum
- Rotor: Painted black
- Electronics housing: Die-cast aluminum

Mechanical characteristics

- Number of blades: 5
- Direction of rotation: Clockwise viewed toward rotor
- Installation position: See product drawing
- Condensation drainage holes: Rotor side
- Mode: Continuous operation (S1)
- Mounting: Maintenance-free ball bearings

Further Information





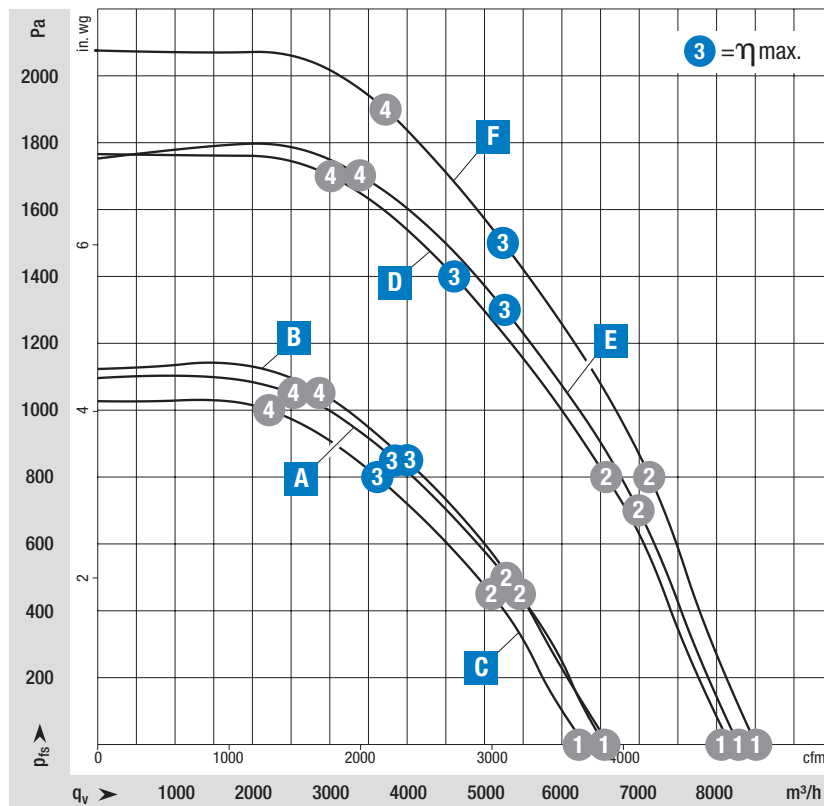









- Information about touch current, electrical connection, degree of protection, insulation class, environmental protection class, EMC standards as well as standards and approvals can be found in the product-specific data sheets.

on Page 48	Drawings
on Page 154	Accessories
on Page 166	Connection diagrams and technical features
on Page 172	Technical parameters & scope
More at	www.ebmpapst.com/worldwide www.ebmpapst.com/radipac



Measuring requirements

Air performance measured according to: ISO 5801, installation category A, with ebm-papst inlet ring without contact protection. Intake-side sound level: L_{wA} according to 13347, L_{wA} measured at 1 m distance from fan axis. The values given are only applicable under the specified measuring conditions and may differ depending on the installation conditions. In the event of deviation from the standard configuration, the parameters must be checked in installed condition.

Curve				Operating point	Nominal voltage	Speed n	Max. Input power P _{in}	Max. Input current I	Sound power level L _{WA}	Perm. ambient temp.	Degree of protection	Conn. diagram	
Nominal voltage range 1-200-277 V AC, 50/60 Hz				VAC	rpm	W	A	dB(A)	°C				
Type	Part number	Fan type											
A	VBS0355PSRLS	R3G355PH3821	Centrifugal fan		①	230	2590	885	3,74	88	-25..+40	IP 54	RP6)
					②	230	2590	1360	5,94	81			
	③	230	2590	1500	6,60	80							
	④	230	2590	1430	6,23	83							
B	VBS0355PSHRS	R3G355PG5421	Centrifugal fan		①	230	2600	920	4,03	98	-25..+40	IP 55	RP6)
					②	230	2600	1340	5,83	86			
	③	230	2600	1500	6,60	79							
	④	230	2600	1500	6,60	82							
VBK0355PSRLS	K3G355PH3822	Support bracket											
VBK0355PSHRS	K3G355PG5422	Support bracket											
Nominal voltage range 3-380-480 V AC, 50/60 Hz				VAC	rpm	W	A	dB(A)	°C				
Type	Part number	Fan type											
C	VBS0355PTPMS	R3G355PT12W1	Centrifugal fan		①	400	2500	735	1,15	95	-40..+40	IP 55	RP3)
					②	400	2500	1060	1,78	81			
	③	400	2500	1300	2,00	77							
	④	400	2500	1200	1,84	81							
VBH0355PTPMS	K3G355PT12W1	Support bracket											
D	VBS0355PTRLS	R3G355PV7001	Centrifugal fan		①	400	3230	1760	2,77	100	-40..+40	IP 55	RP4)
					②	400	3230	2500	3,85	90			
	③	400	3230	2900	4,40	85							
	④	400	3230	2690	4,13	88							
VBH0355PTRLS	K3G355PV7001	Support bracket											
E	VBS0355PTRLS	R3G355PV7002	Centrifugal fan		①	400	3230	1630	2,58	102	-40..+40	IP 55	RP4)
					②	400	3230	2540	3,91	89			
	③	400	3230	2900	4,40	83							
	④	400	3230	2625	4,04	89							
---	---	Support bracket											
F	VBS0355PTRNS	R3G355PW0701	Centrifugal fan		①	400	3550	2100	3,27	105	-40..+60	IP 20	RP4)
					②	400	3550	3150	4,81	94			
	③	400	3550	3750	5,70	86							
	④	400	3550	3605	5,48	91							
---	---	Support bracket											

Subject to change

Values set in blue are nominal data at operating point with maximum load.

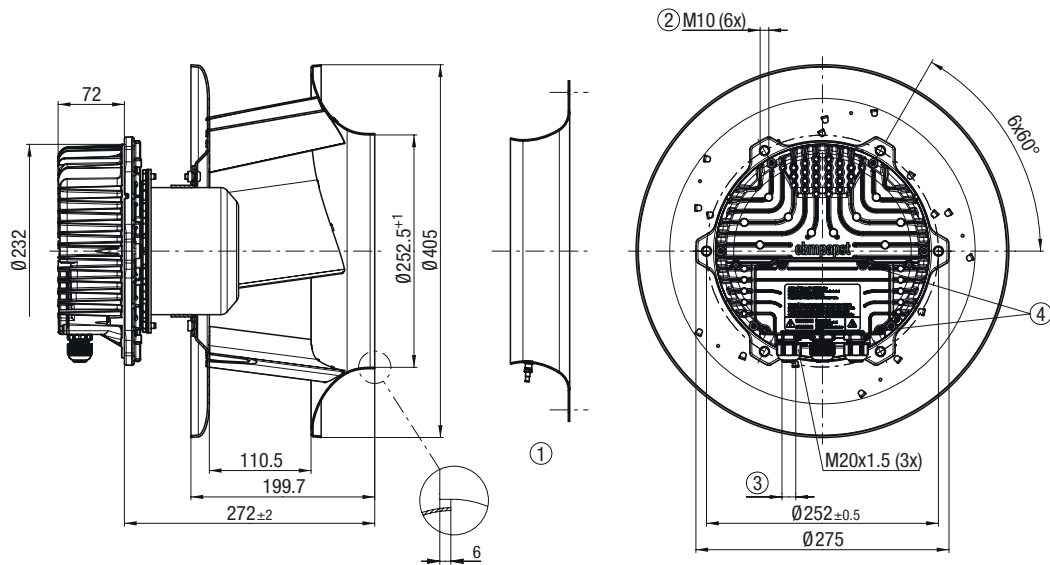

- ① **Accessory part:** Inlet ring 35675-2-4013 with pressure tap (k-factor: 148) not included in scope of delivery (Dimensions: see "Accessories" chapter)
- ② **Max. clearance of screw:** 16 mm
- ③ **Cable gland M20 x 1.5:** Cable diameter min. 4 mm, max. 10 mm, Tightening torque 4 ± 0.6 Nm
- ④ **Tightening torque:** 3.5 ± 0.5 Nm

Pin assignment: (see connection diagram)
Installation position: Shaft horizontal or rotor on bottom, rotor on top on request

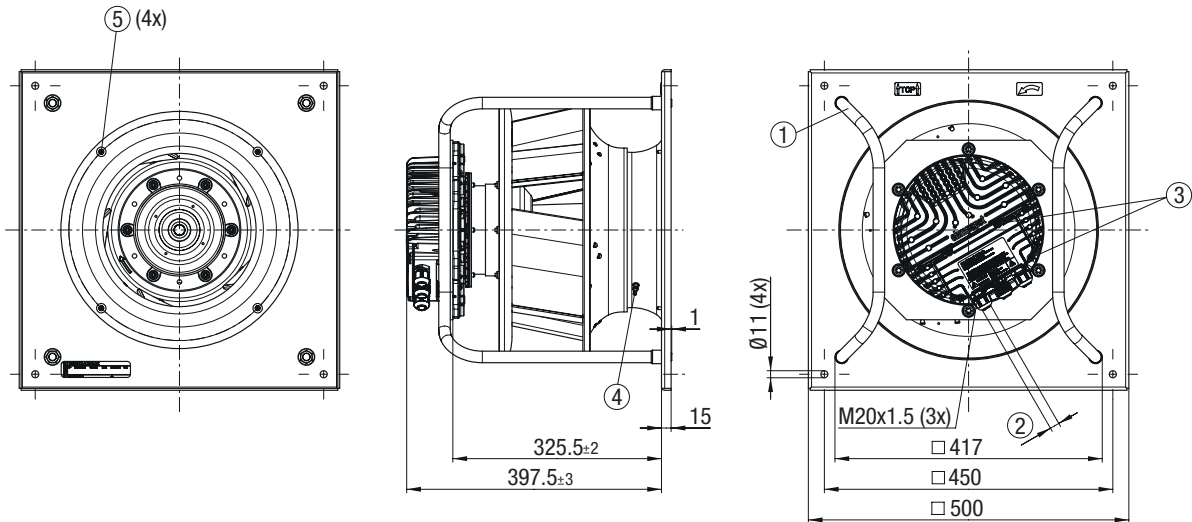

- ① **Installation position:** Shaft horizontal (Install support struts only vertically according to view!) or rotor on bottom, rotor on top on request
- ② **Cable gland M20 x 1.5:** Cable diameter min. 4 mm, max. 10 mm, Tightening torque 4 ± 0.6 Nm
- ③ **Tightening torque:** 3.5 ± 0.5 Nm
- ④ **Inlet ring:** with pressure tap (k-factor: 148)
- ⑤ **Mounting holes:** for FlowGrid

Pin assignment: (see connection diagram)

B VBS0355PSRHS R3G355PG5421 (EC centrifugal fan)

Dimensions in mm

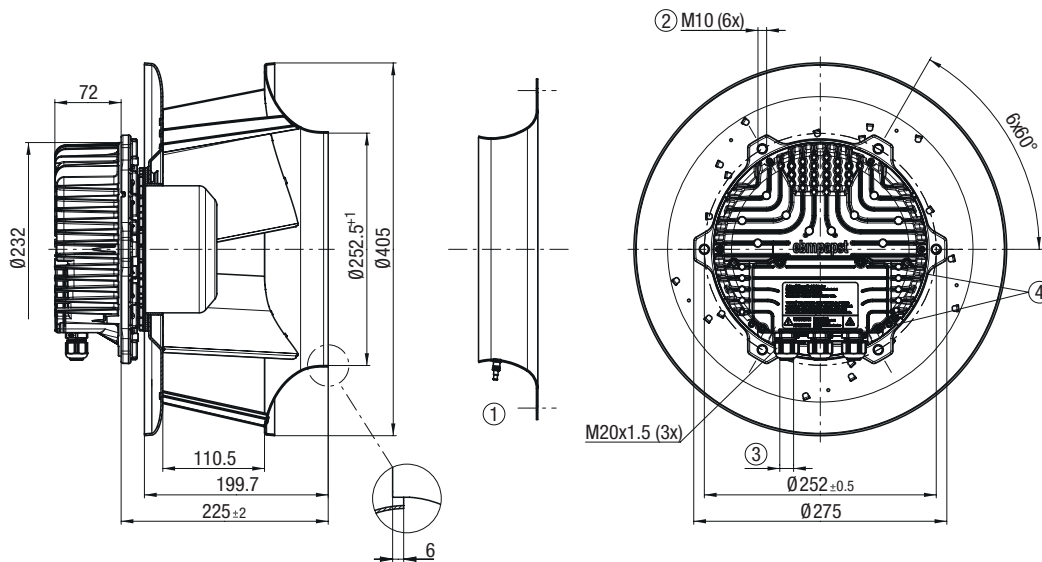

- ① **Accessory part:** Inlet ring 35675-2-4013 with pressure tap (k-factor: 148) not included in scope of delivery (Dimensions: see "Accessories" chapter)
- ② **Max. clearance of screw:** 20 mm
- ③ **Cable gland M20 x 1.5:** Cable diameter min. 4 mm, max. 10 mm, Tightening torque 4 ± 0.6 Nm
- ④ **Tightening torque:** 3.5 ± 0.5 Nm

Pin assignment: (see connection diagram)
Installation position: Shaft horizontal or rotor on bottom, rotor on top on request

B VBH0355PSRHS K3G355PG5422 (EC centrifugal module with support bracket)

Dimensions in mm

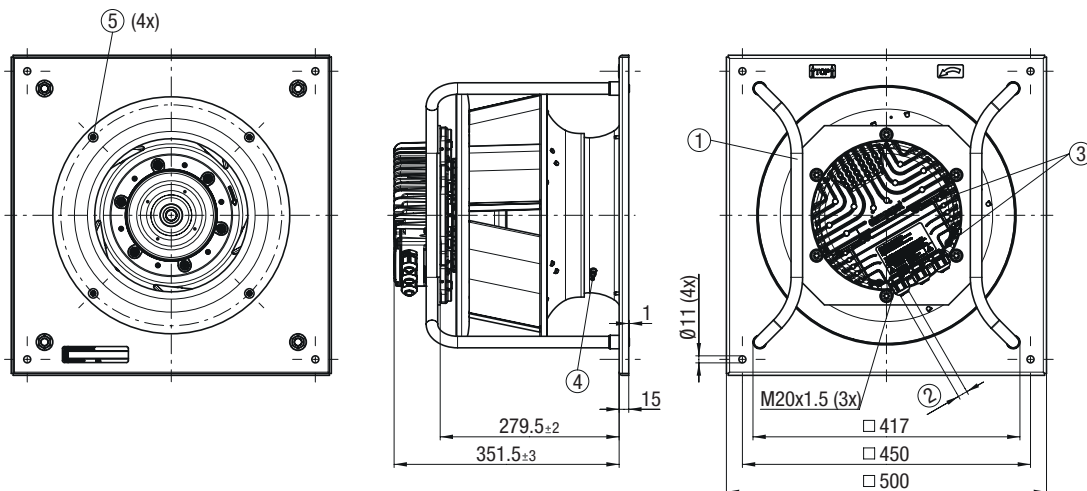

- ① **Installation position:** Shaft horizontal (Install support struts only vertically according to view!) or rotor on bottom, rotor on top on request
- ② **Cable gland M20 x 1.5:** Cable diameter min. 4 mm, max. 10 mm, Tightening torque 4 ± 0.6 Nm
- ③ **Tightening torque:** 3.5 ± 0.5 Nm
- ④ **Inlet ring:** with pressure tap (k-factor: 148)
- ⑤ **Mounting holes:** for FlowGrid

Pin assignment: (see connection diagram)

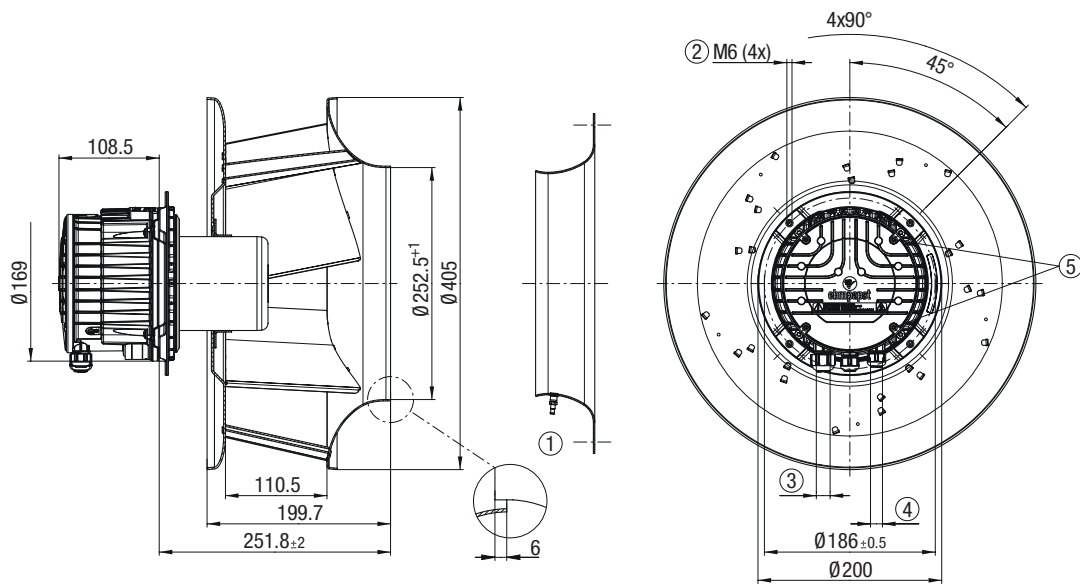

- ① **Accessory part:** Inlet ring 35675-2-4013 with pressure tap (k-factor: 148) not included in scope of delivery (Dimensions: see "Accessories" chapter)
- ② **Max. clearance of screw:** 16 mm
- ③ **Cable gland M20 x 1.5:** Cable diameter min. 8 mm, max. 12 mm, Tightening torque 1.8 ± 0.3 Nm (use must be made of seal provided)
Cable diameter min. 4 mm, max. 10 mm, Tightening torque 1.8 ± 0.3 Nm
- ④ **Cable gland M16 x 1.5 (2x):** Cable diameter min. 6 mm, max. 10 mm, Tightening torque 1.8 ± 0.3 Nm (use must be made of seal provided)
Cable diameter min. 4 mm, max. 7 mm, Tightening torque 1.8 ± 0.3 Nm
- ⑤ **Tightening torque:** 1.5 ± 0.2 Nm

Pin assignment: (see connection diagram)
Installation position: Shaft horizontal or rotor on bottom, rotor on top on request

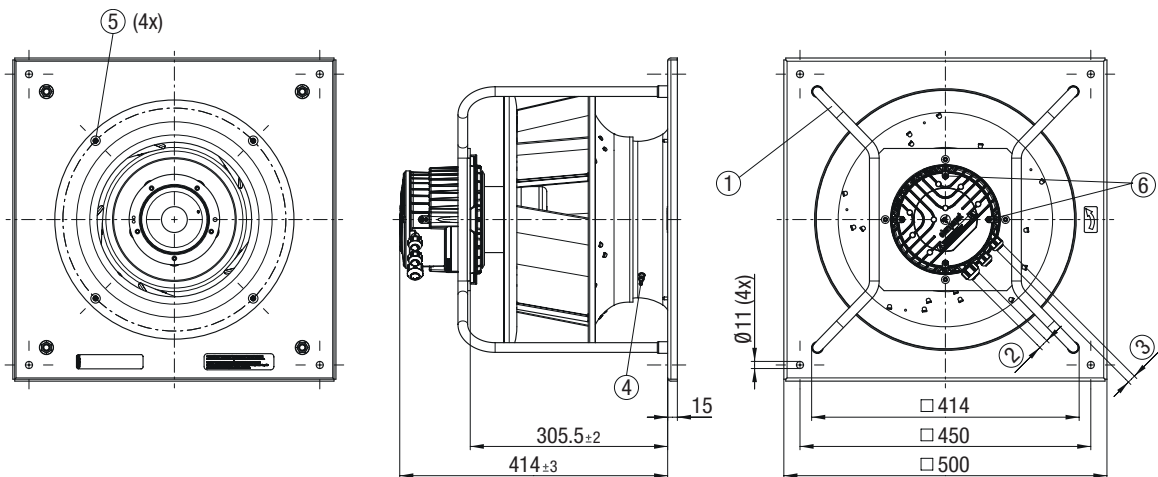

- ① **Installation position:** Shaft horizontal (Install support struts only vertically according to view!) or rotor on bottom, rotor on top on request
- ② **Cable gland M20 x 1.5:** Cable diameter min. 8 mm, max. 12 mm, Tightening torque 1.8 ± 0.3 Nm (use must be made of seal provided)
Cable diameter min. 4 mm, max. 10 mm, Tightening torque 1.8 ± 0.3 Nm
- ③ **Cable gland M16 x 1.5 (2x):** Cable diameter min. 6 mm, max. 10 mm, Tightening torque 1.8 ± 0.3 Nm (use must be made of seal provided)
Cable diameter min. 4 mm, max. 7 mm, Tightening torque 1.8 ± 0.3 Nm
- ④ **Inlet ring:** with pressure tap (k-factor: 148)
- ⑤ **Mounting holes:** for FlowGrid
- ⑥ **Tightening torque:** 1.5 ± 0.2 Nm

Pin assignment: (see connection diagram)

D VBS0355PTRLS R3G355PV7001 (EC centrifugal fan)

Dimensions in mm

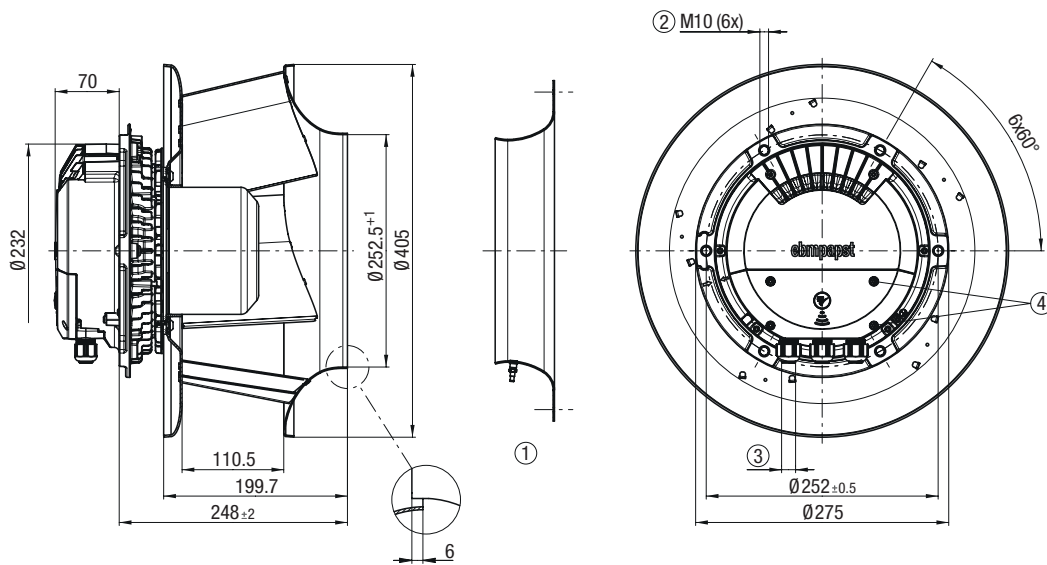

- ① Accessory part: Inlet ring 35675-2-4013 with pressure tap (k-factor: 148) not included in scope of delivery (Dimensions: see "Accessories" chapter)
- ② Max. clearance of screw: 20 mm
- ③ Cable gland M20 x 1.5: Cable diameter min. 4 mm, max. 10 mm, Tightening torque 4 ± 0.6 Nm
- ④ Tightening torque: 1.5 ± 0.2 Nm

Pin assignment: (see connection diagram)
 Installation position: Shaft horizontal or rotor on bottom, rotor on top on request

D VBH0355PTRLS K3G355PV7001 (EC centrifugal module with support bracket)

Dimensions in mm

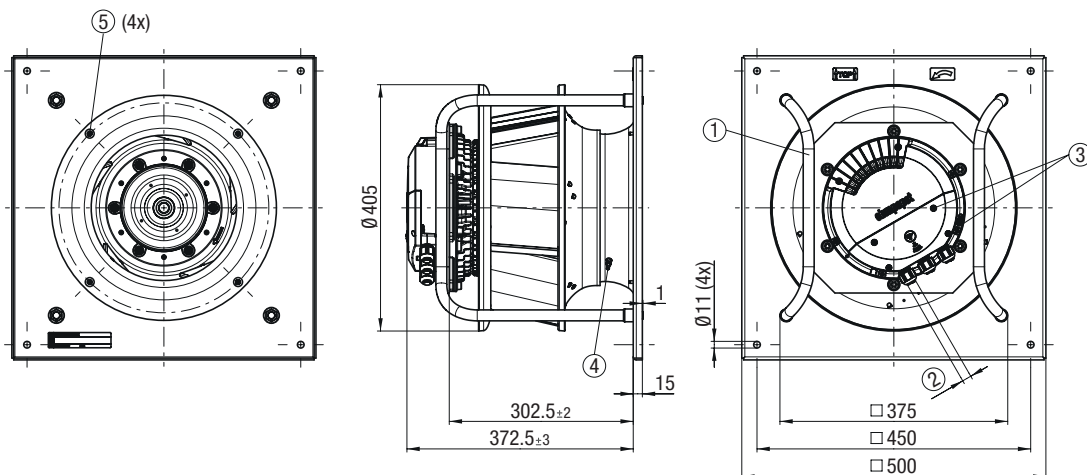

- ① Installation position: Shaft horizontal (Install support struts only vertically according to view!) or rotor on bottom, rotor on top on request
- ② Cable gland M20 x 1.5: Cable diameter min. 4 mm, max. 10 mm, Tightening torque 4 ± 0.6 Nm
- ③ Tightening torque: 1.5 ± 0.2 Nm
- ④ Inlet ring: with pressure tap (k-factor: 148)
- ⑤ Mounting holes: for FlowGrid

Pin assignment: (see connection diagram)

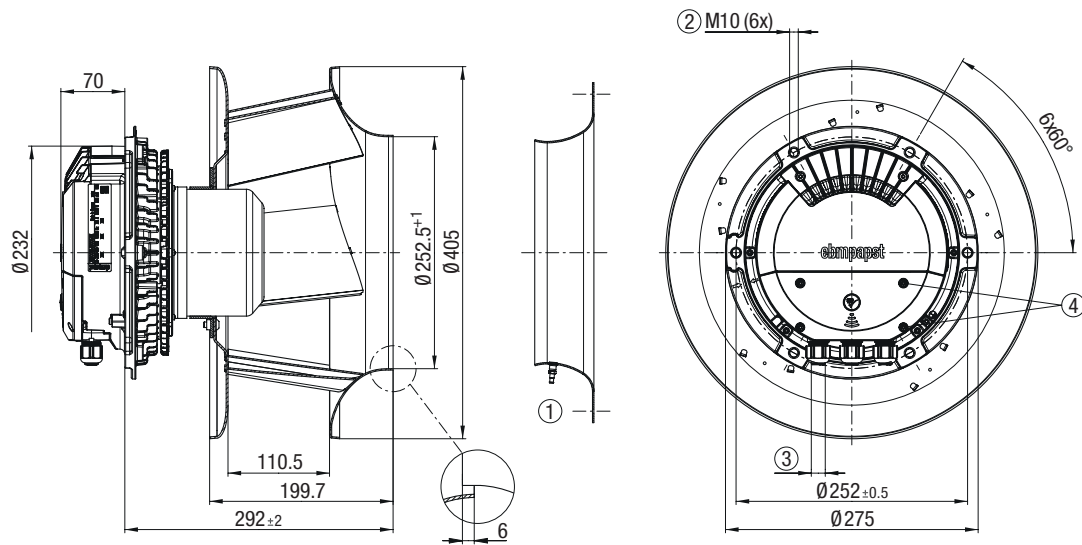

- ① **Accessory part:** Inlet ring 35675-2-4013 with pressure tap (k-factor: 148) not included in scope of delivery (Dimensions: see "Accessories" chapter)
- ② **Max. clearance of screw:** 20 mm
- ③ **Cable gland M20 x 1.5:** Cable diameter min. 4 mm, max. 10 mm, Tightening torque 4 ± 0.6 Nm
- ④ **Tightening torque:** 1.5 ± 0.2 Nm

Pin assignment: (see connection diagram)

Installation position: Shaft horizontal or rotor on bottom, rotor on top on request

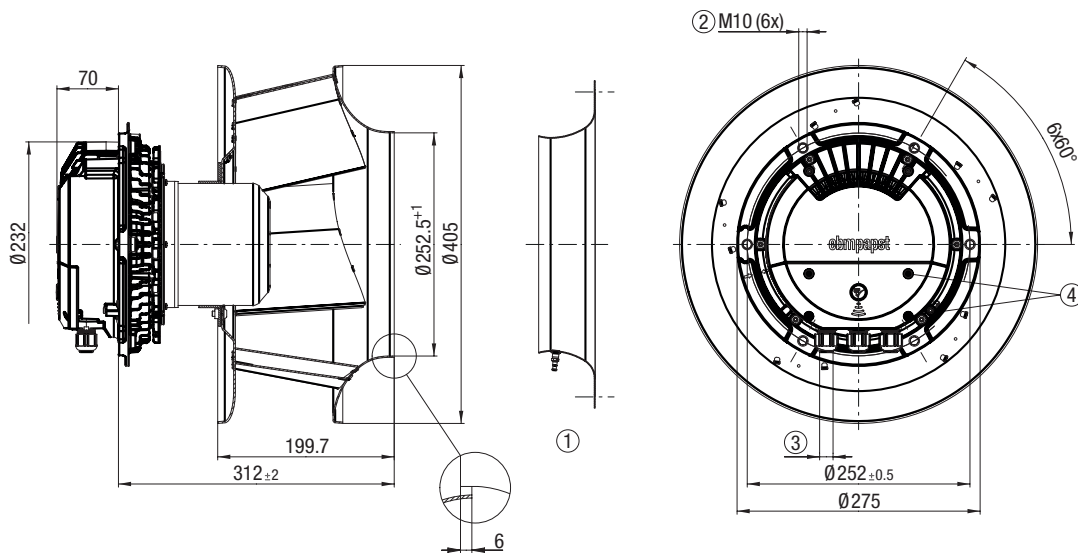

- ① **Accessory part:** Inlet ring 35675-2-4013 with pressure tap (k-factor: 148) not included in scope of delivery (Dimensions: see "Accessories" chapter)
- ② **Max. clearance of screw:** 20 mm
- ③ **Cable gland M20 x 1.5:** Cable diameter min. 4 mm, max. 10 mm, Tightening torque 4 ± 0.6 Nm
- ④ **Tightening torque:** 1.5 ± 0.2 Nm

Pin assignment: (see connection diagram)

Installation position: Shaft horizontal or rotor on bottom, rotor on top on request

RadiPac 400

EC centrifugal fans, backward curved



Material/surface

- Support bracket: Steel, painted black
- Support plate: Sheet steel, galvanized
- Spacer: aluminum
- Inlet ring: Sheet steel, galvanized
- Impeller: Sheet aluminum
- Rotor: Painted black
- Electronics housing: Die-cast aluminum

Mechanical characteristics

- Number of blades: 5
- Direction of rotation: Clockwise viewed toward rotor
- Installation position: See product drawing
- Condensation drainage holes: Rotor side
- Mode: Continuous operation (S1)
- Mounting: Maintenance-free ball bearings

Further Information





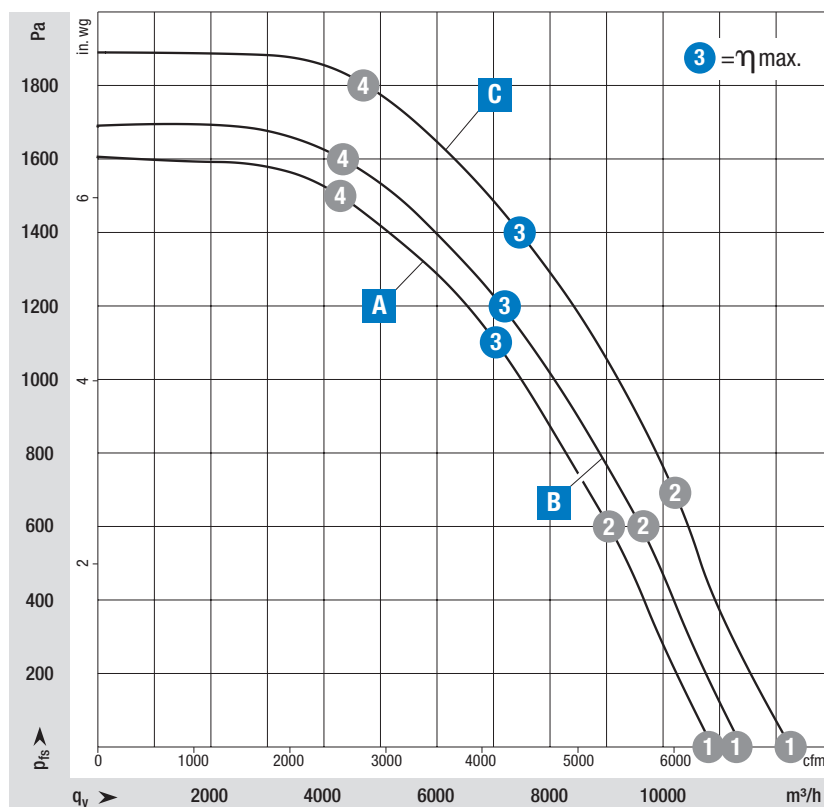

- Information about touch current, electrical connection, degree of protection, insulation class, environmental protection class, EMC standards as well as standards and approvals can be found in the product-specific data sheets.

on Page 56	Drawings
on Page 154	Accessories
on Page 166	Connection diagrams and technical features
on Page 172	Technical parameters & scope
More at	www.ebmpapst.com/worldwide www.ebmpapst.com/radipac



Measuring requirements

Air performance measured according to: ISO 5801, installation category A, with ebm-papst inlet ring without contact protection. Intake-side sound level: L_{wA} according to 13347, L_{wA} measured at 1 m distance from fan axis. The values given are only applicable under the specified measuring conditions and may differ depending on the installation conditions. In the event of deviation from the standard configuration, the parameters must be checked in installed condition.

Curve				Operating point	Nominal voltage	Speed n	Max. Input power P_{in}	Max. Input current I	Sound power level L _{WA}	Perm. ambient temp.	Degree of protection	Conn. diagram	
Nominal voltage range 3-380-480 V AC, 50/60 Hz				VAC	rpm	W	A	dB(A)	°C				
Type	Part number	Fan type											
A	VBS0400PTRNS	R3G400PW0301	Centrifugal fan		① 400	2700	2175	3,38	98	-40..+40	IP 55	RP4)	
				② 400	2700	2980	4,57	90					
				③ 400	2700	3400	5,20	85					
				④ 400	2700	3140	4,81	87					
B	VBS0400PTTLS	R3G400PA2703	Centrifugal fan							-40..+40	IP 55	RP4)	
	VBS0400PTTLS	R3G400PA2765	Centrifugal fan										
					① 400	2800	2290	3,54	98				
					② 400	2800	3220	4,92	91				
					③ 400	2800	3650	5,50	86				
					④ 400	2800	3430	5,23	89				
C	VBS0400PTTLS	R3G400PA2702	Centrifugal fan		① 400	2980	2540	3,92	100	-40..+40	IP 55	RP4)	
				② 400	2980	3800	5,80	91					
				③ 400	2980	4400	6,70	87					
				④ 400	2980	4120	6,29	91					
	---	---	Support bracket										

Subject to change

Values set in blue are nominal data at operating point with maximum load.

RadiPac 400

A VBS0400PTRNS R3G400PW0301 (EC centrifugal fan)

Dimensions in mm

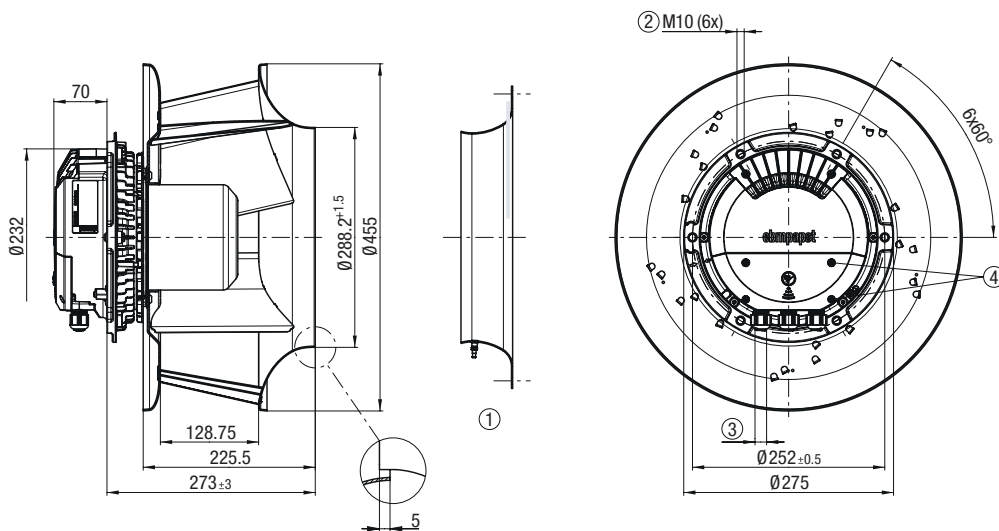

- ① **Accessory part:** Inlet ring 40078-2-4013 with pressure tap (k-factor: 188) not included in scope of delivery (Dimensions: see "Accessories" chapter)
- ② **Max. clearance of screw:** 20 mm
- ③ **Cable gland M20 x 1.5:** Cable diameter min. 4 mm, max. 10 mm, Tightening torque 4 ± 0.6 Nm
- ④ **Tightening torque:** 1.5 ± 0.2 Nm

Pin assignment: (see connection diagram)
Installation position: Shaft horizontal or rotor on bottom, rotor on top on request

A VBK0400PTRNS K3G400PW0301 (EC centrifugal module with support bracket)

Dimensions in mm

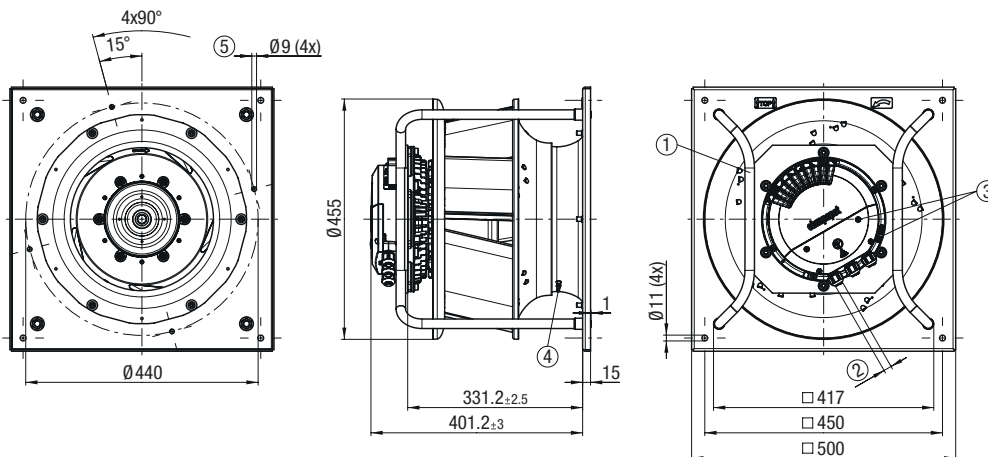

- ① **Installation position:** Shaft horizontal (Install support struts only vertically according to view!) or rotor on bottom, rotor on top on request
- ② **Cable gland M20 x 1.5:** Cable diameter min. 4 mm, max. 10 mm, Tightening torque 4 ± 0.6 Nm
- ③ **Tightening torque:** 1.5 ± 0.2 Nm
- ④ **Inlet ring:** with pressure tap (k-factor: 188)
- ⑤ **Mounting holes:** for FlowGrid

Pin assignment: (see connection diagram)

B VBS0400PTTLS R3G400PA2703 & R3G400PA2765 (EC centrifugal fan)

Dimensions in mm

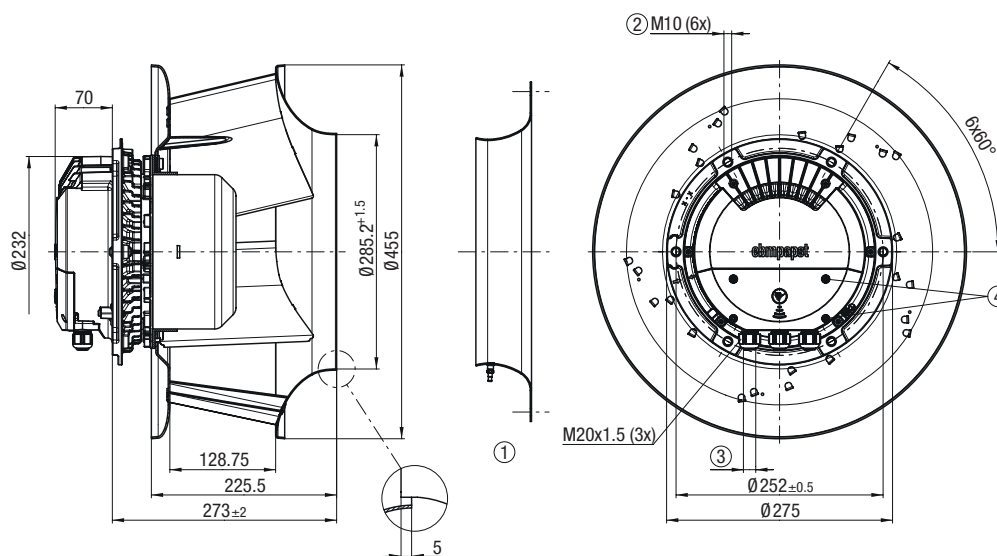

- ① **Accessory part:** Inlet ring 40075-2-4013 with pressure tap (k-factor: 188) not included in scope of delivery (Dimensions: see "Accessories" chapter)
- ② **Max. clearance of screw:** 20 mm
- ③ **Cable gland M20 x 1.5:** Cable diameter min. 4 mm, max. 10 mm, Tightening torque 4 ± 0.6 Nm
- ④ **Tightening torque:** 1.5 ± 0.2 Nm

Pin assignment: (see connection diagram)
Installation position: Shaft horizontal or rotor on bottom, rotor on top on request

B VBH0400PTTLS K3G400PA2703 (EC centrifugal module with support bracket)

Dimensions in mm

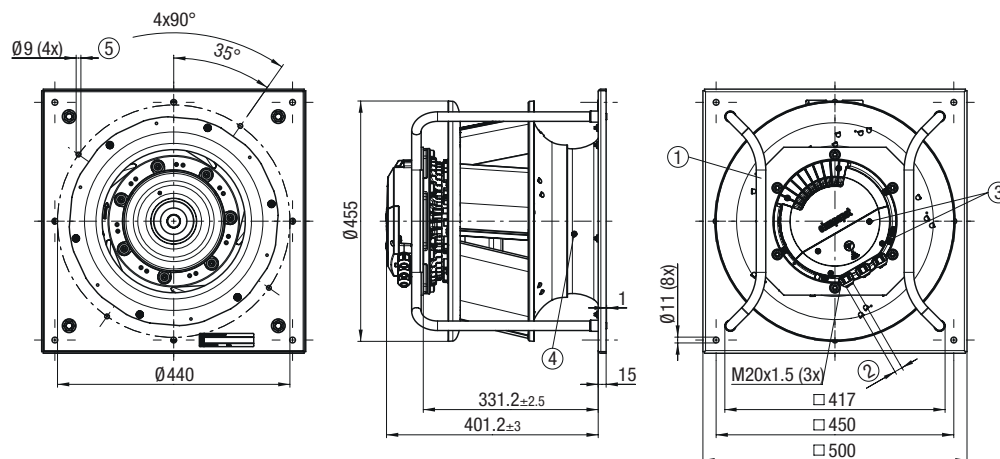

- ① **Installation position:** Shaft horizontal (Install support struts only vertically according to view!) or rotor on bottom, rotor on top on request
- ② **Cable gland M20 x 1.5:** Cable diameter min. 4 mm, max. 10 mm, Tightening torque 4 ± 0.6 Nm
- ③ **Tightening torque:** 1.5 ± 0.2 Nm
- ④ **Inlet ring:** with pressure tap (k-factor: 188)
- ⑤ **Mounting holes:** for FlowGrid

Pin assignment: (see connection diagram)

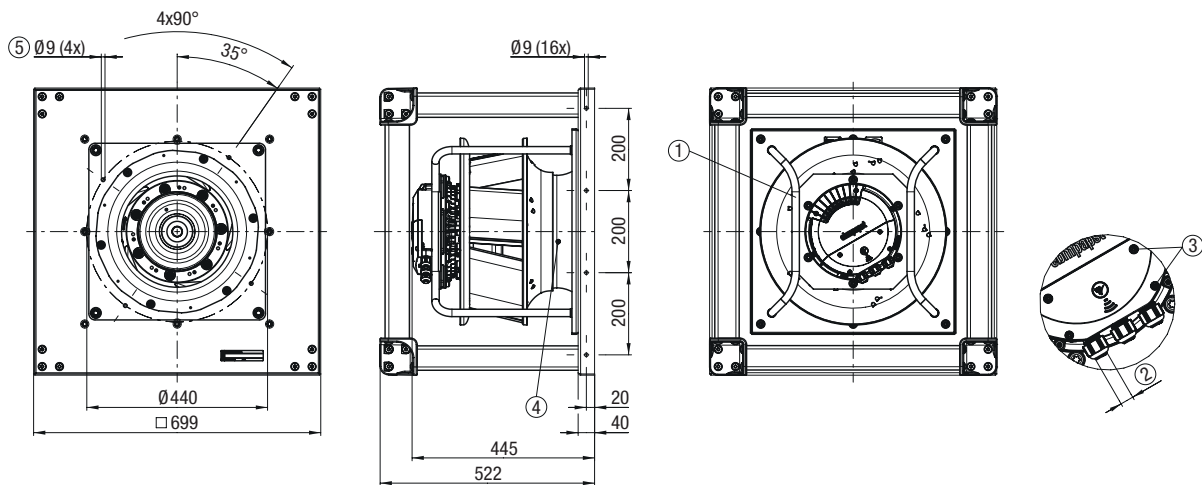

- ① **Installation position:** Shaft horizontal (Install support struts only vertically according to view!)
- ② **Cable gland M20 x 1.5:** Cable diameter min. 4 mm, max. 10 mm, Tightening torque 4 ± 0.6 Nm
- ③ **Tightening torque:** 1.5 ± 0.2 Nm
- ④ **Inlet ring:** with pressure tap (k-factor: 188)
- ⑤ **Mounting holes:** for FlowGrid

Pin assignment: (see connection diagram)

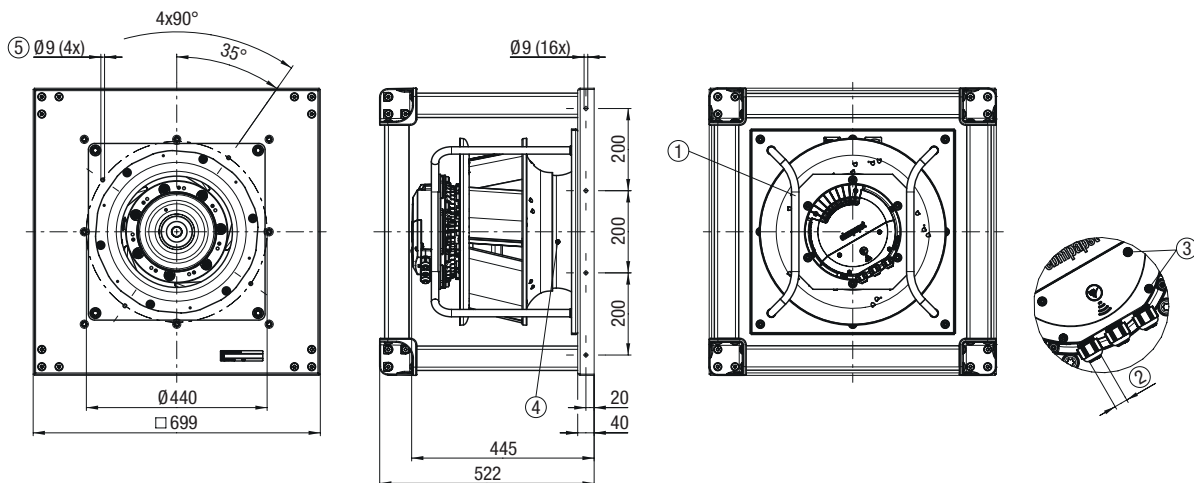

- ① **Installation position:** Shaft horizontal (Install support struts only vertically according to view!)
- ② **Cable gland M20 x 1.5:** Cable diameter min. 4 mm, max. 10 mm, Tightening torque 4 ± 0.6 Nm
- ③ **Tightening torque:** 1.5 ± 0.2 Nm
- ④ **Inlet ring:** with pressure tap (k-factor: 188)
- ⑤ **Mounting holes:** for FlowGrid

Pin assignment: (see connection diagram)

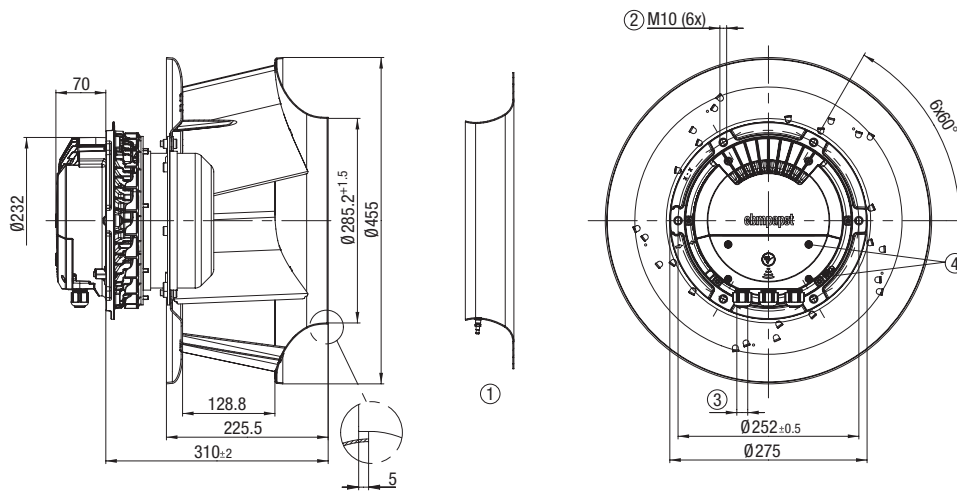

- ① **Accessory part:** Inlet ring 40075-2-4013 with pressure tap (k-factor: 188)
not included in scope of delivery (Dimensions: see "Accessories" chapter)
- ② **Max. clearance of screw:** 20 mm
- ③ **Cable gland M20 x 1.5:** Cable diameter min. 4 mm, max. 10 mm, Tightening torque 4 ± 0.6 Nm
- ④ **Tightening torque:** 1.5 ± 0.2 Nm

Pin assignment: (see connection diagram)

Installation position: Shaft horizontal or
rotor on bottom, rotor on top on request

RadiPac 450

EC centrifugal fans, backward curved



Material/surface

- Support bracket: Steel, painted black
- Support plate: Sheet steel, galvanized
- Spacer: aluminum
- Inlet ring: Sheet steel, galvanized
- Impeller: Sheet aluminum
- Rotor: Painted black
- Electronics housing: Die-cast aluminum

Mechanical characteristics

- Number of blades: 5
- Direction of rotation: Clockwise viewed toward rotor
- Installation position: See product drawing
- Condensation drainage holes: Rotor side
- Mode: Continuous operation (S1)
- Mounting: Maintenance-free ball bearings

Further Information





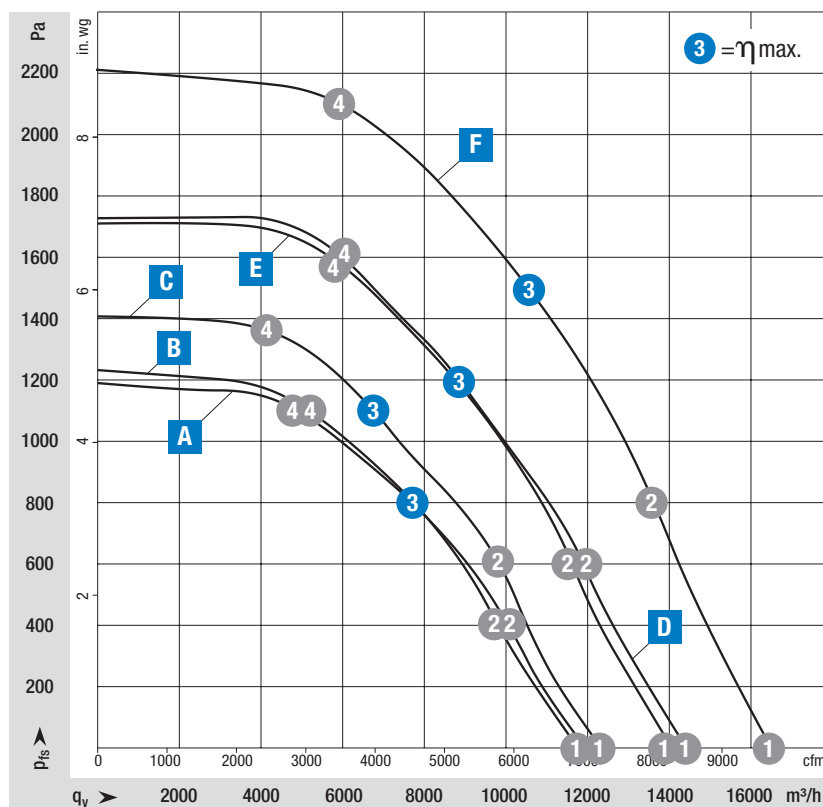









- Information about touch current, electrical connection, degree of protection, insulation class, environmental protection class, EMC standards as well as standards and approvals can be found in the product-specific data sheets.

on Page 62	Drawings
on Page 154	Accessories
on Page 166	Connection diagrams and technical features
on Page 172	Technical parameters & scope
More at	www.ebmpapst.com/worldwide www.ebmpapst.com/radipac



Measuring requirements

Air performance measured according to: ISO 5801, installation category A, with ebm-papst inlet ring without contact protection. Intake-side sound level: L_{wA} according to 13347, L_{wA} measured at 1 m distance from fan axis. The values given are only applicable under the specified measuring conditions and may differ depending on the installation conditions. In the event of deviation from the standard configuration, the parameters must be checked in installed condition.

Curve				Operating point	Nominal voltage	Speed n	Max. Input power P_{id}	Max. Input current I	Sound power level L _{WA}	Perm. ambient temp.	Degree of protection	Conn. diagram		
Nominal voltage range 3-380-480 V AC, 50/60 Hz				VAC	rpm	W	A	dB(A)	°C					
Type	Part number	Fan type												
A	VBS0450PTRNS	R3G450PW1202	Centrifugal fan		①	400	2040	1515	2,42	93	-40..+40	IP 55	RP4)	
					②	400	2040	2160	3,36	86				
	③	400	2040	2650	4,10	79								
	④	400	2040	2530	3,90	85								
---	---	Support bracket												
B	VBS0450PTRNS	R3G450PW1201	Centrifugal fan		①	400	2040	1625	2,58	95	-40..+40	IP 55	RP4)	
					②	400	2040	2210	3,43	87				
	③	400	2040	2650	4,10	80								
	④	400	2040	2585	3,99	84								
VBH0450PTRNS	K3G450PW1201	Support bracket												
C	VBS0450PTTLS	R3G450PA21C1	Centrifugal fan		PFC active	①	400	2200	1960	2,84	96	-25..+40	IP 55	RP1)
						②	400	2200	2915	4,20	88			
	③	400	2200	3190	4,60	87								
	④	400	2200	3000	4,33	90								
VBH0450PTTLS	K3G450PA21C1	Support bracket		PFC active										
D	VBS0450PTTLS	R3G450PA3102	Centrifugal fan		①	400	2480	2775	4,26	99	-40..+40	IP 55	RP4)	
					②	400	2480	3895	5,93	91				
	③	400	2480	4450	6,80	85								
	④	400	2480	4450	6,80	89								
---	---	Support bracket												
E	VBS0450PTTLS	R3G450PA3103	Centrifugal fan											
	VBS0450PTTLS	R3G450PA3165	Centrifugal fan											
	VBH0450PTTLS	K3G450PA3103	Support bracket		Resonance-sensor	①	400	2480	2775	4,26	99	-40..+45	IP 55	RP4)
						②	400	2480	3925	5,98	92			
	③	400	2480	4450	6,80	85								
	④	400	2480	4415	6,71	89								
VBH0450PTTLS	K3G450PA31W3	Cube (FanGrid)												
VBH0450PTTLS	K3G450PA31W5	Cube (FanGrid)		Resonance-sensor										
F	VBS0450PTTPS	R3G450PB29L1	Centrifugal fan		Resonance-sensor	①	400	2800	3945	6,06	102	-40..+40	IP 55	RP4)
						②	400	2800	5685	8,65	95			
	③	400	2800	6800	10,3	88								
	④	400	2800	6130	9,32	93								
VBH0450PTTPS	K3G450PB29L1	Support bracket		Resonance-sensor										
VBH0450PTTPS	K3G450PB29N3	Cube (FanGrid)		Resonance-sensor										

Subject to change

Values set in blue are nominal data at operating point with maximum load.

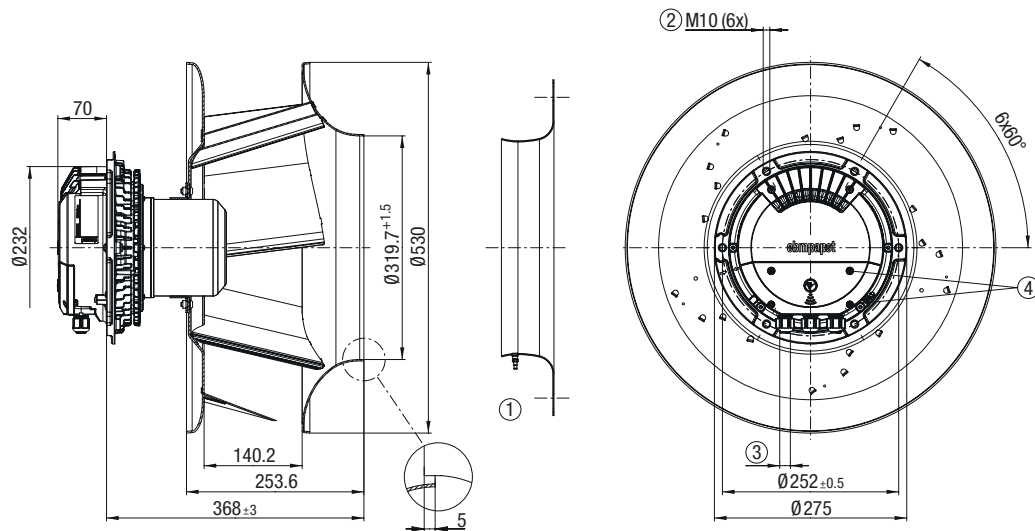

- ① **Accessory part:** Inlet ring 45075-2-4013 with pressure tap (k-factor: 240) not included in scope of delivery (Dimensions: see "Accessories" chapter)
- ② **Max. clearance of screw:** 20 mm
- ③ **Cable diameter:** min. 4 mm, max. 10 mm, Tightening torque 4±0,6 Nm
- ④ **Tightening torque:** 1,5±0,2 Nm

Pin assignment: (see connection diagram)

Installation position: Shaft horizontal or rotor on bottom, rotor on top on request

B VBS0450PTRNS R3G450PW1201 (EC centrifugal fan)

Dimensions in mm

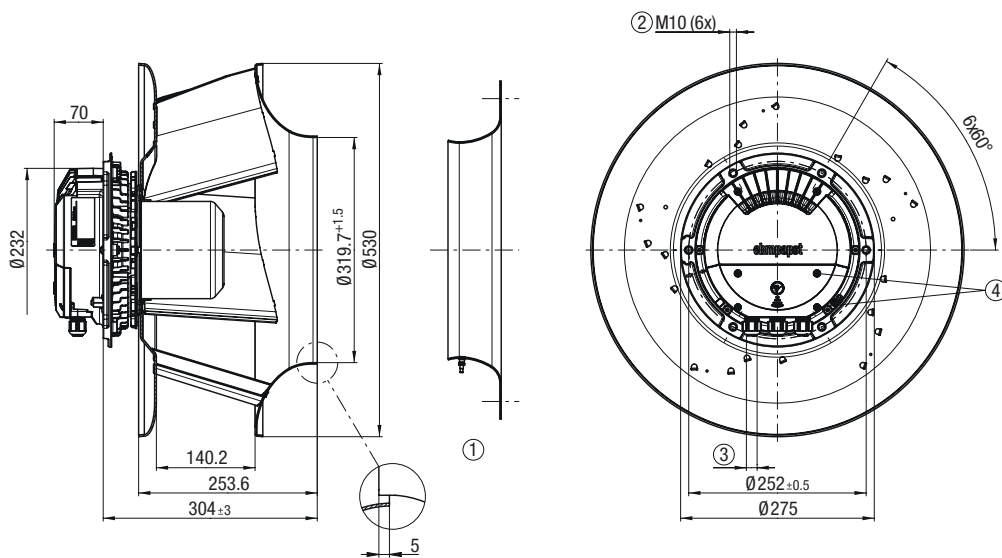

- ① **Accessory part:** Inlet ring 45075-2-4013 with pressure tap (k-factor: 240) not included in scope of delivery (Dimensions: see "Accessories" chapter)
- ② **Max. clearance of screw:** 20 mm
- ③ **Cable diameter:** min. 4 mm, max. 10 mm, Tightening torque $4 \pm 0,6$ Nm
- ④ **Tightening torque:** $1,5 \pm 0,2$ Nm

Pin assignment: (see connection diagram)

Installation position: Shaft horizontal or rotor on bottom, rotor on top on request

B VBH0450PTRNS K3G450PW1201 (EC centrifugal module with support bracket)

Dimensions in mm

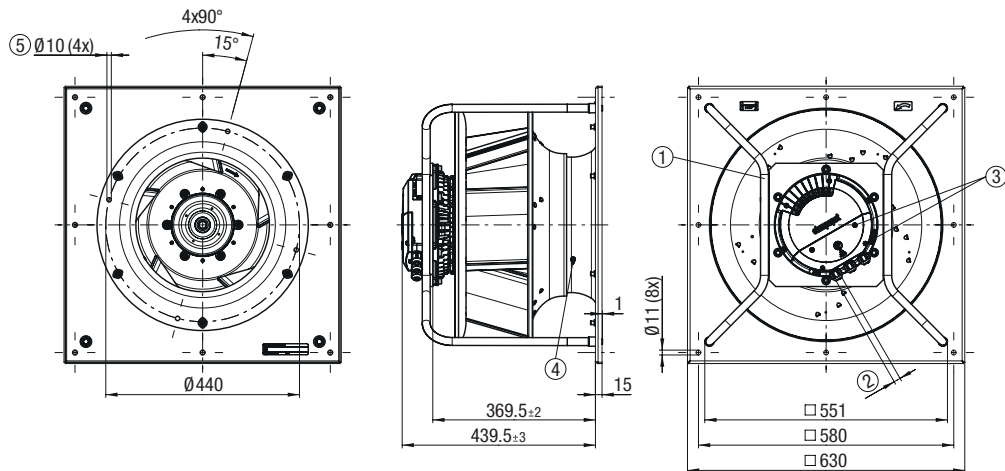

- ① **Installation position:** Shaft horizontal (Install support struts only vertically according to view!) or rotor on bottom, rotor on top on request
- ② **Cable diameter:** min. 4 mm, max. 10 mm, Tightening torque $4 \pm 0,6$ Nm
- ③ **Tightening torque:** $1,5 \pm 0,2$ Nm
- ④ **Inlet ring:** with pressure tap (k-factor: 240)
- ⑤ **Mounting holes:** for FlowGrid

Pin assignment: (see connection diagram)

RadiPac 450

C VBS0450PTTLS R3G450PA21C1 (EC centrifugal fan and PFC, active)

Dimensions in mm

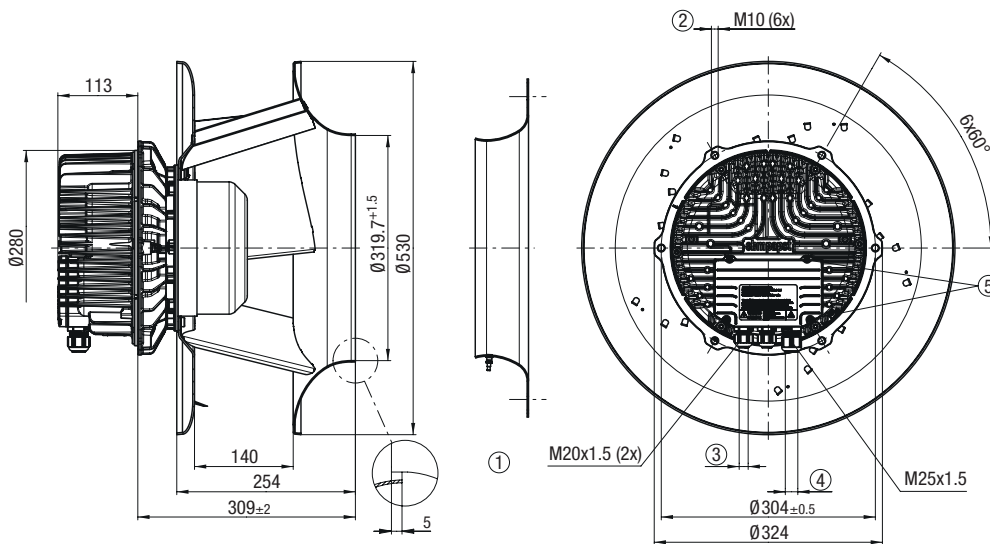

- ① **Accessory part:** Inlet ring 45075-2-4013 with pressure tap (k-factor: 240) not included in scope of delivery (Dimensions: see "Accessories" chapter)
- ② **Max. clearance of screw:** 20 mm
- ③ **Cable diameter:** min. 4 mm, max. 10 mm, Tightening torque $4 \pm 0,6$ Nm
- ④ **Cable diameter:** min. 9 mm, max. 16 mm, Tightening torque $6 \pm 0,9$ Nm
- ⑤ **Tightening torque:** $3,5 \pm 0,5$ Nm

Pin assignment: (see connection diagram)
Installation position: Shaft horizontal or rotor on bottom, rotor on top on request

C VBH0450PTTLS K3G450PA21C1 (EC centrifugal module with support bracket and PFC, active)

Dimensions in mm

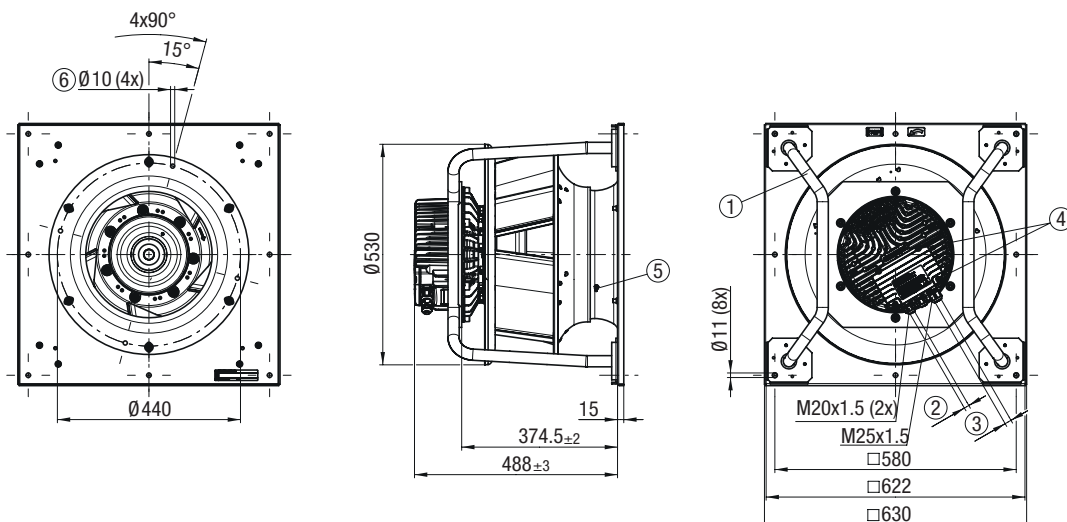

- ① **Installation position:** Shaft horizontal (Install support struts only vertically according to view!) or rotor on bottom, rotor on top on request
- ② **Cable diameter:** min. 4 mm, max. 10 mm, Tightening torque $4 \pm 0,6$ Nm
- ③ **Cable diameter:** min. 9 mm, max. 16 mm, Tightening torque $6 \pm 0,9$ Nm
- ④ **Tightening torque:** $3,5 \pm 0,5$ Nm
- ⑤ **Inlet ring:** with pressure tap (k-factor: 240)
- ⑥ **Mounting holes:** for FlowGrid

Pin assignment: (see connection diagram)

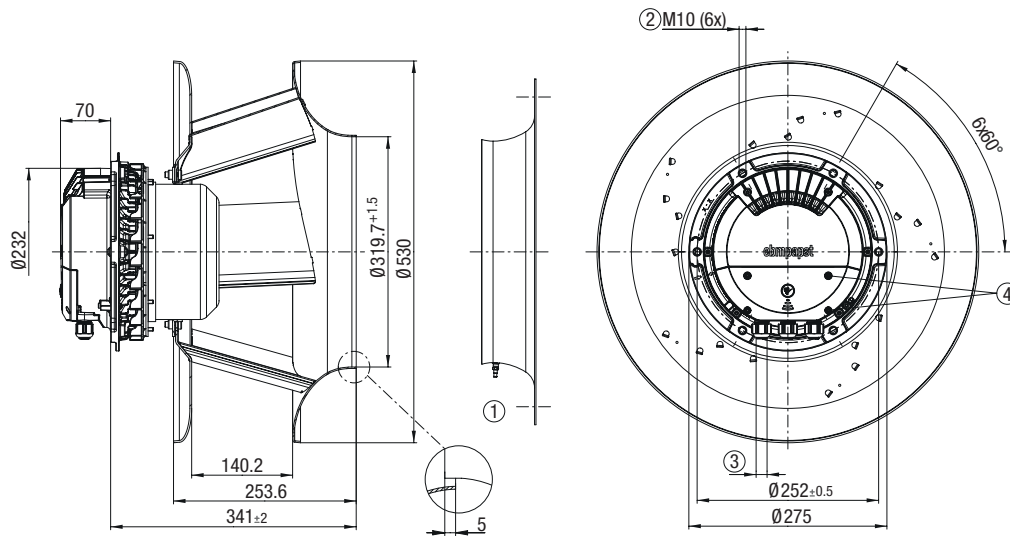

- ① **Accessory part:** Inlet ring 45075-2-4013 with pressure tap (k-factor: 240) not included in scope of delivery (Dimensions: see "Accessories" chapter)
- ② **Max. clearance of screw:** 20 mm
- ③ **Cable diameter:** min. 4 mm, max. 10 mm, Tightening torque $4 \pm 0,6$ Nm
- ④ **Tightening torque:** $1,5 \pm 0,2$ Nm

Pin assignment: (see connection diagram)

Installation position: Shaft horizontal or rotor on bottom, rotor on top on request

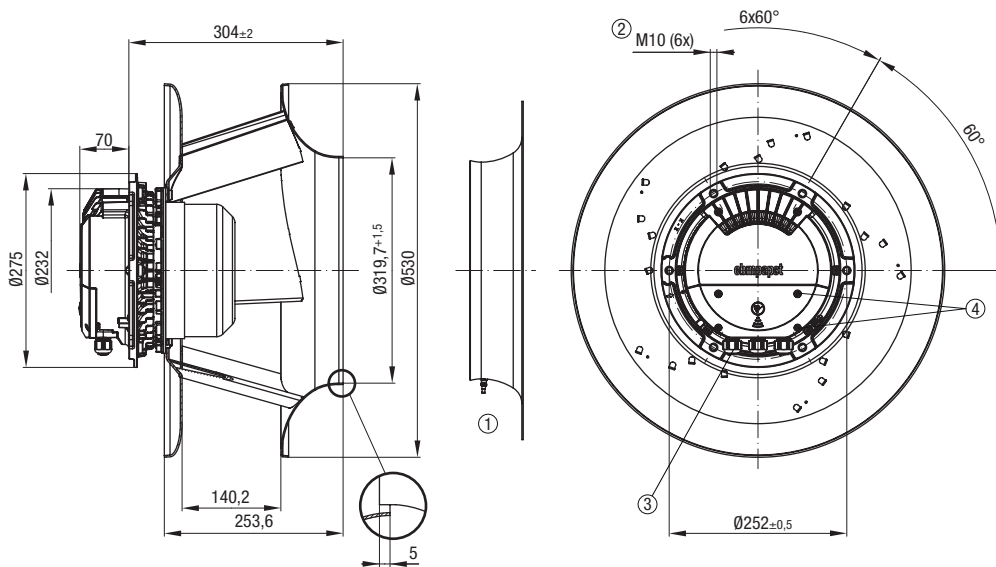

- ① **Accessory part:** Inlet ring 45075-2-4013 with pressure tap (k-factor: 240) not included in scope of delivery (Dimensions: see "Accessories" chapter)
- ② **Max. clearance of screw:** 20 mm
- ③ **Cable diameter:** min. 4 mm, max. 10 mm, Tightening torque 4±0,6 Nm
- ④ **Tightening torque:** 1,5±0,2 Nm

Pin assignment: (see connection diagram)
Installation position: Shaft horizontal or rotor on bottom, rotor on top on request

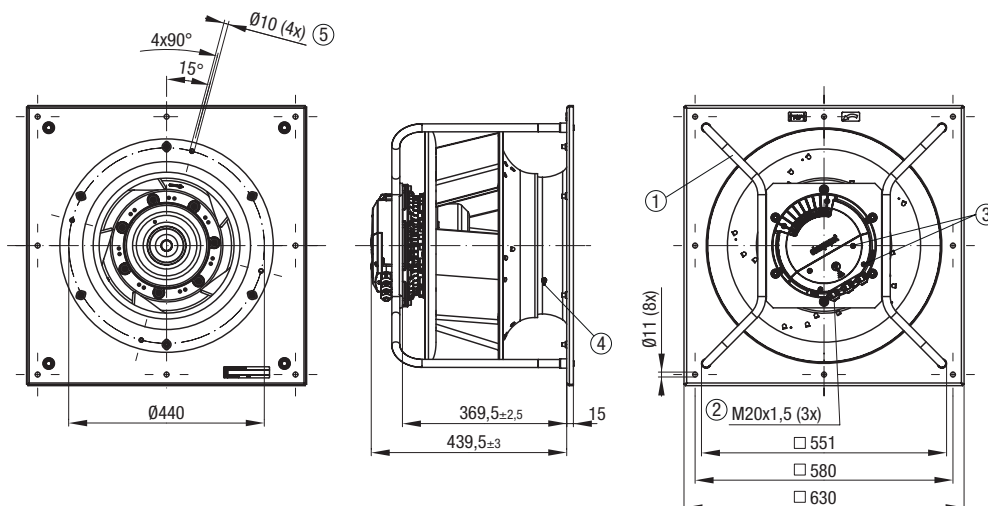

- ① **Installation position:** Shaft horizontal (Install support struts only vertically according to view!) or rotor on bottom, rotor on top on request
- ② **Cable diameter:** min. 4 mm, max. 10 mm, Tightening torque 4±0,6 Nm
- ③ **Tightening torque:** 1,5±0,2 Nm
- ④ **Inlet ring:** with pressure tap (k-factor: 240)
- ⑤ **Mounting holes:** for FlowGrid

Pin assignment: (see connection diagram)

E VBH0450PTTLS K3G450PA31W3 (EC centrifugal module with cube design / FanGrid)

Dimensions in mm

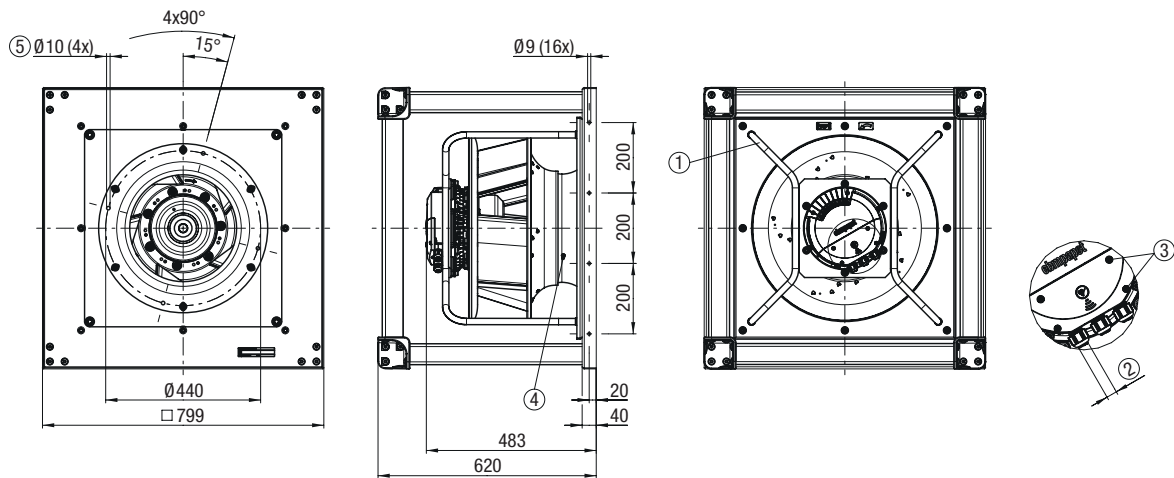

- ① **Installation position:** Shaft horizontal (Install support struts only vertically according to view!)
- ② **Cable gland M20 x 1.5:** Cable diameter min. 4 mm, max. 10 mm, Tightening torque 4 ± 0.6 Nm
- ③ **Tightening torque:** 1.5 ± 0.2 Nm
- ④ **Inlet ring:** with pressure tap (k-factor: 240)
- ⑤ **Mounting holes:** for FlowGrid

Pin assignment: (see connection diagram)

E VBH0450PTTLS K3G450PA31W5 (EC centrifugal module with cube design / FanGrid)

Dimensions in mm

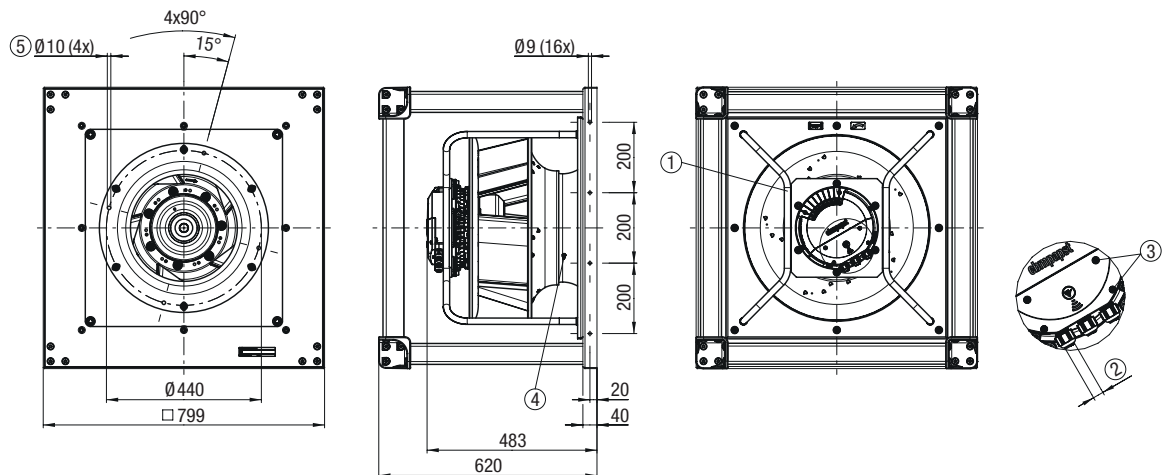

- ① **Installation position:** Shaft horizontal (Install support struts only vertically according to view!)
- ② **Cable gland M20 x 1.5:** Cable diameter min. 4 mm, max. 10 mm, Tightening torque 4 ± 0.6 Nm
- ③ **Tightening torque:** 1.5 ± 0.2 Nm
- ④ **Inlet ring:** with pressure tap (k-factor: 240)
- ⑤ **Mounting holes:** for FlowGrid

Pin assignment: (see connection diagram)

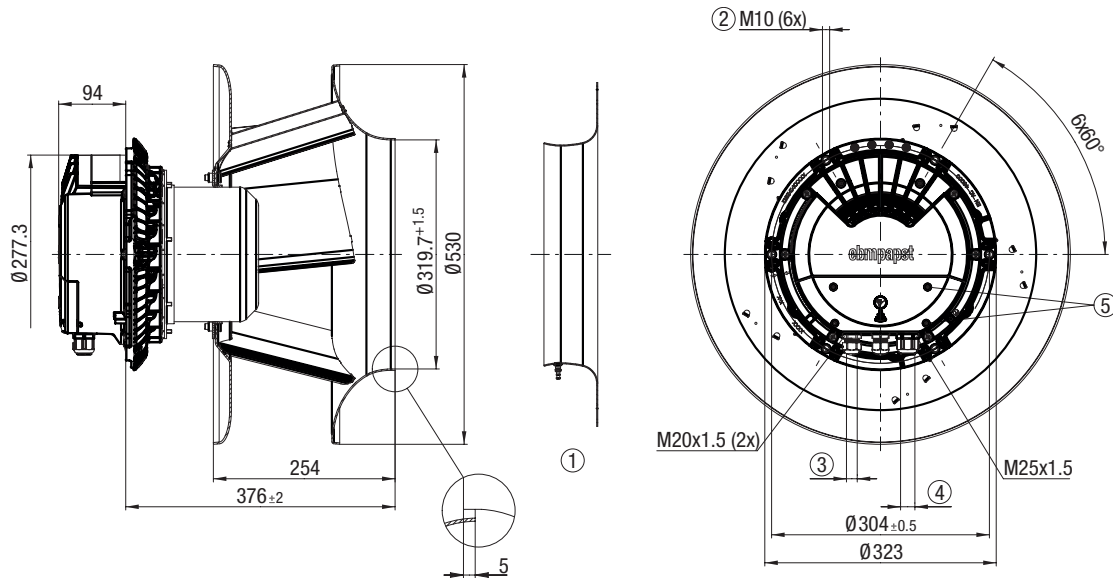

- ① **Accessory part:** Inlet ring 45075-2-4013 with pressure tap (k-factor: 240) not included in scope of delivery (Dimensions: see "Accessories" chapter)
- ② **Max. clearance of screw:** 20 mm
- ③ **Cable diameter:** min. 4 mm, max. 10 mm, Tightening torque 4±0,6 Nm
- ④ **Cable diameter:** min. 5 mm, max. 14 mm, Tightening torque 6±0,9 Nm
- ⑤ **Tightening torque:** 2,8±0,3 Nm

Pin assignment: (see connection diagram)
Installation position: Shaft horizontal or rotor on bottom, rotor on top on request

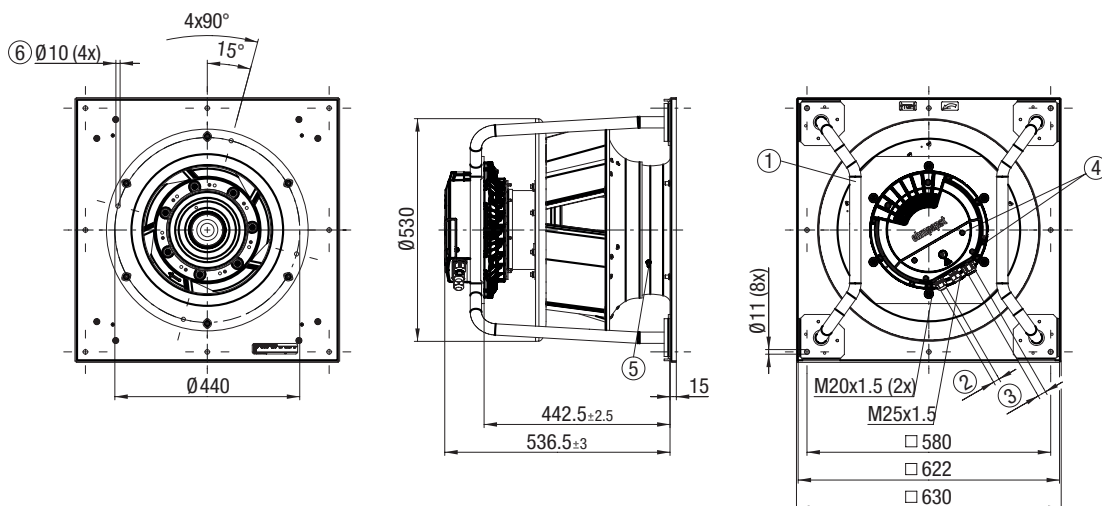

- ① **Installation position:** Shaft horizontal (Install support struts only vertically according to view!) or rotor on bottom, rotor on top on request
- ② **Cable diameter:** min. 4 mm, max. 10 mm, Tightening torque 4±0,6 Nm
- ③ **Cable diameter:** min. 5 mm, max. 14 mm, Tightening torque 6±0,9 Nm
- ④ **Tightening torque:** 2,8±0,3 Nm
- ⑤ **Inlet ring:** with pressure tap (k-factor: 240)
- ⑥ **Mounting holes:** for FlowGrid

Pin assignment: (see connection diagram)

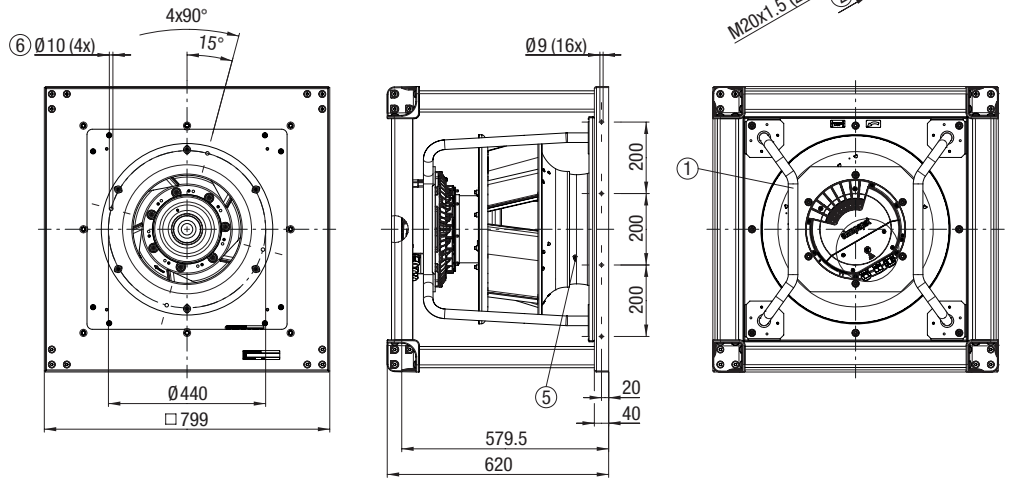

- ① Installation position: Shaft horizontal (Install support struts only vertically according to view!)
- ② Cable diameter: min. 4 mm, max. 10 mm, Tightening torque $4 \pm 0,6$ Nm
- ③ Cable diameter: min. 5 mm, max. 14 mm, Tightening torque $6 \pm 0,9$ Nm
- ④ Tightening torque: $2,8 \pm 0,3$ Nm
- ⑤ Inlet ring: with pressure tap (k-factor: 240)
- ⑥ Mounting holes: for FlowGrid

Pin assignment: (see connection diagram)

RadiPac 500

EC centrifugal fans, backward curved



Material/surface

- Support bracket: Steel, painted black
- Support plate: Sheet steel, galvanized
- Spacer: aluminum
- Inlet ring: Sheet steel, galvanized
- Impeller: Sheet aluminum
- Rotor: Painted black
- Electronics housing: Die-cast aluminum

Mechanical characteristics

- Number of blades: 5
- Direction of rotation: Clockwise viewed toward rotor
- Installation position: See product drawing
- Condensation drainage holes: Rotor side
- Mode: Continuous operation (S1)
- Mounting: Maintenance-free ball bearings

Further Information





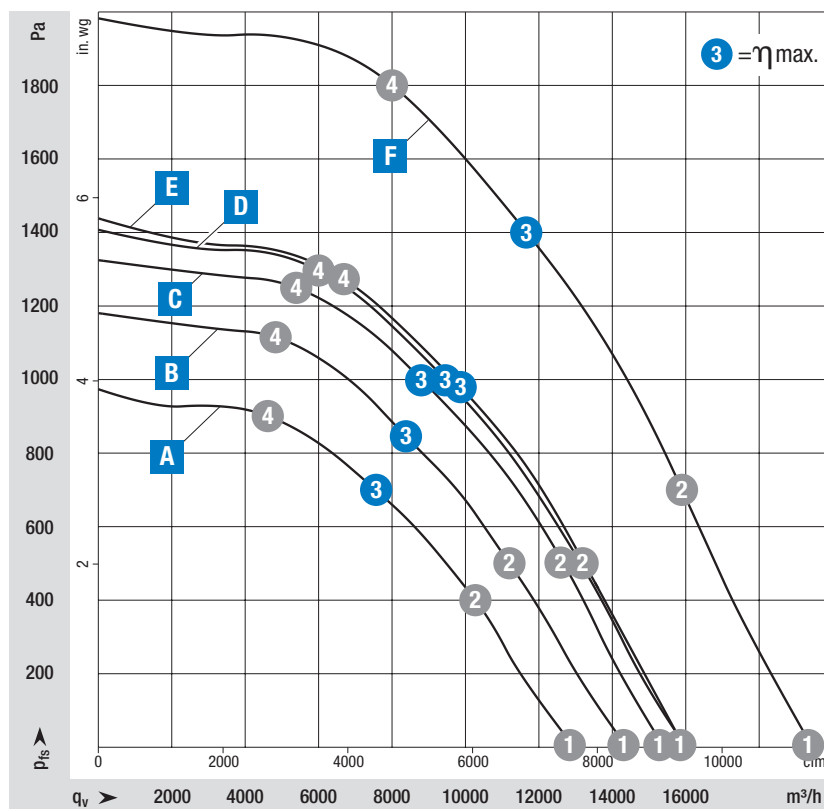









- Information about touch current, electrical connection, degree of protection, insulation class, environmental protection class, EMC standards as well as standards and approvals can be found in the product-specific data sheets.

on Page 72	Drawings
on Page 154	Accessories
on Page 166	Connection diagrams and technical features
on Page 172	Technical parameters & scope
More at	www.ebmpapst.com/worldwide www.ebmpapst.com/radipac



Measuring requirements

Air performance measured according to: ISO 5801, installation category A, with ebm-papst inlet ring without contact protection. Intake-side sound level: L_{pA} according to 13347, L_{pA} measured at 1 m distance from fan axis. The values given are only applicable under the specified measuring conditions and may differ depending on the installation conditions. In the event of deviation from the standard configuration, the parameters must be checked in installed condition.

Curve				Operating point	Nominal voltage	Speed n	Max. Input power P_{id}	Max. Input current I	Sound power level L _{WA}	Perm. ambient temp.	Degree of protection	Conn. diagram			
Nominal voltage range 3-380-480 V AC, 50/60 Hz				VAC	rpm	W	A	dB(A)	°C						
Type	Part number	Fan type													
A	VBS0500PTRNS	R3G500PW0901	Centrifugal fan		①	400	1670	1340	2,17	100	-40..+40	IP 55	RP4)		
					②	400	1670	2020	3,16	89					
	③	400	1670	2350	3,60	80									
	④	400	1670	2175	3,39	83									
VBH0500PTRNS	K3G500PW0901	Support bracket			①	400	1670	1340	2,17	100					
					②	400	1670	2020	3,16	89					
B	VBS0500PTTLS	R3G500PA26C1	Centrifugal fan		PFC active	①	400	1810	1800	2,60	102	-25..+40	IP 55	RP1)	
						②	400	1810	2700	3,90	91				
	③	400	1810	3100	4,50	82									
	④	400	1810	2850	4,10	86									
VBH0500PTTLS	K3G500PA26C1	Support bracket			PFC active	①	400	1810	1800	2,60	102				
						②	400	1810	2700	3,90	91				
C	VBS0500PTTLS	R3G500PA2803	Centrifugal fan			①	400	1890	2020	3,16	101	-40..+40	IP 55	RP4)	
						②	400	1890	2950	4,53	92				
	③	400	1890	3350	5,20	85									
	④	400	1890	3165	4,85	87									
VBH0500PTTLS	K3G500PA2803	Support bracket				①	400	1890	2020	3,16	101				
						②	400	1890	2950	4,53	92				
D	VBS0500PTTPS	R3G500PB2402	Centrifugal fan			①	400	2000	2290	3,55	103	-40..+45	IP 55	RP4)	
						②	400	2000	3290	5,03	94				
	③	400	2000	3900	6,00	86									
	④	400	2000	3725	5,68	89									
...	...	Support bracket				①	400	2000	2290	3,55	103				
						②	400	2000	3290	5,03	94				
E	VBS0500PTTPS	R3G500PB2403	Centrifugal fan			①	400	2000	2290	3,55	103	-40..+45	IP 55	RP4)	
						②	400	2000	3290	5,03	94				
	③	400	2000	3900	6,00	86									
	④	400	2000	3750	5,71	88									
	VBH0500PTTPS	K3G500PB2403	Support bracket			Resonance-sensor	①	400	2000	2410	3,73				101
							②	400	2000	3375	5,15				93
VBH0500PTTPS	K3G500PB24W3	Cube (FanGrid)			Resonance-sensor	③	400	2000	3900	6,00	86				
						④	400	2000	3750	5,71	88				
F	VBS0500PTTRS	R3G500PC16L1	Centrifugal fan		Resonance-sensor	①	400	2400	3920	6,15	108	-40..+40	IP 55	RP4)	
						②	400	2400	5760	8,86	100				
	③	400	2400	7000	10,7	90									
	④	400	2400	6665	10,2	92									
	VBH0500PTTRS	K3G500PC16L1	Support bracket			Resonance-sensor	①	400	2400	3920	6,15				108
							②	400	2400	5760	8,86				100
VBF0500PTTRS	K3G500PC16N3	Cube (FanGrid)			Resonance-sensor	③	400	2400	7000	10,7	90				
						④	400	2400	6665	10,2	92				

Subject to change

Values set in blue are nominal data at operating point with maximum load.

RadiPac 500

A VBS0500PTRNS R3G500PW0901 (EC centrifugal fan)

Dimensions in mm

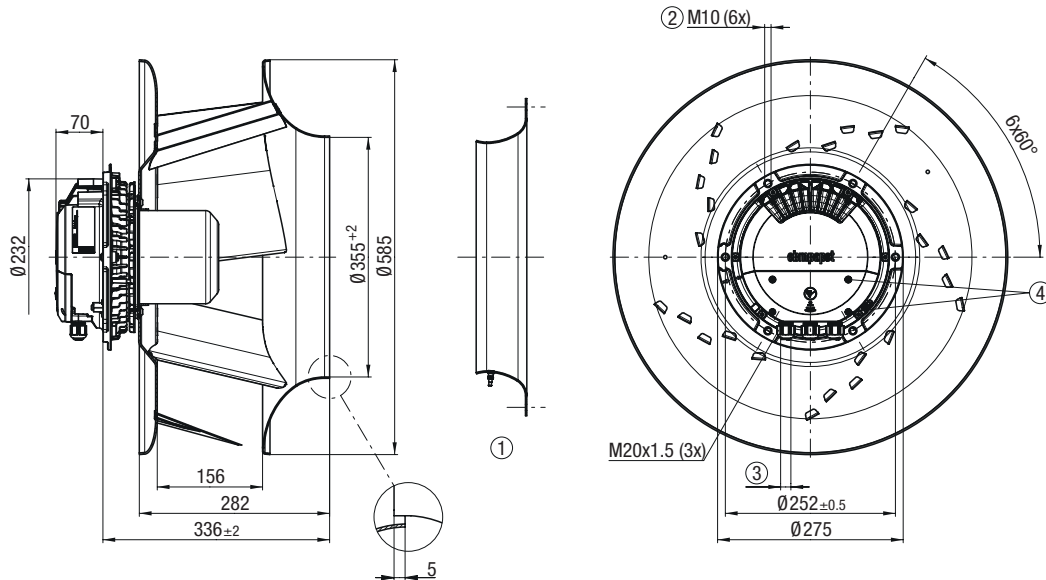

- ① **Accessory part:** Inlet ring 64025-2-4013 with pressure tap (k-factor: 281) not included in scope of delivery (Dimensions: see "Accessories" chapter)
- ② **Max. clearance of screw:** 20 mm
- ③ **Cable diameter:** min. 4 mm, max. 10 mm, Tightening torque $4 \pm 0,6$ Nm
- ④ **Tightening torque:** $1,5 \pm 0,2$ Nm

Pin assignment: (see connection diagram)
Installation position: Shaft horizontal or rotor on bottom, rotor on top on request

A VBH0500PTRNS K3G500PW0901 (EC centrifugal module with support bracket)

Dimensions in mm

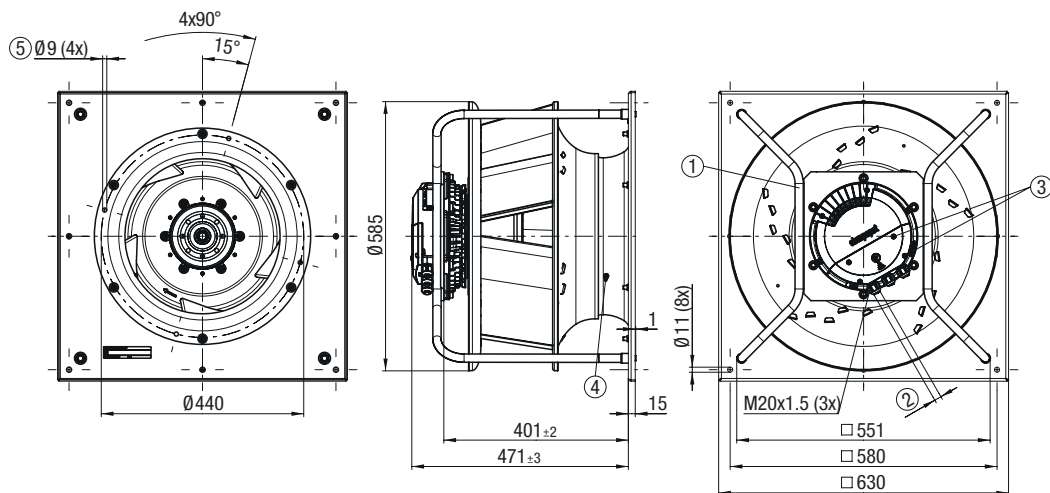

- ① **Installation position:** Shaft horizontal (Install support struts only vertically according to view!) or rotor on bottom, rotor on top on request
- ② **Cable diameter:** min. 4 mm, max. 10 mm, Tightening torque $4 \pm 0,6$ Nm
- ③ **Tightening torque:** $1,5 \pm 0,2$ Nm
- ④ **Inlet ring:** with pressure tap (k-factor: 281)
- ⑤ **Mounting holes:** for FlowGrid

Pin assignment: (see connection diagram)

B VBS0500PTTLS R3G500PA26C1 (EC centrifugal fan with PFC, active)

Dimensions in mm

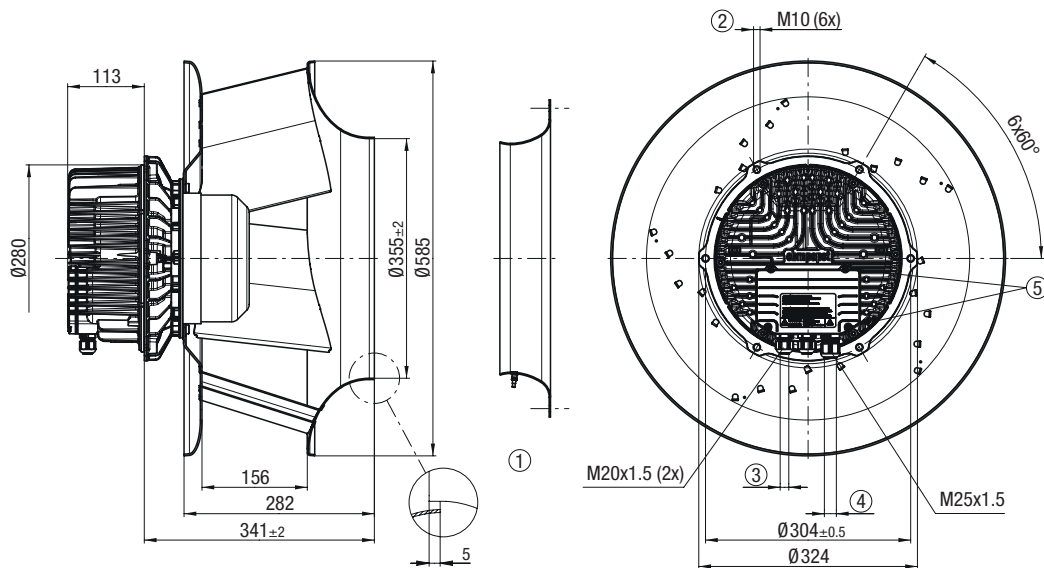

- ① **Accessory part:** Inlet ring 64025-2-4013 with pressure tap (k-factor: 281) not included in scope of delivery (Dimensions: see "Accessories" chapter)
- ② **Max. clearance of screw:** 20 mm
- ③ **Cable diameter:** min. 4 mm, max. 10 mm, Tightening torque $4\pm0,6$ Nm
- ④ **Cable diameter:** min. 9 mm, max. 16 mm, Tightening torque $6\pm0,9$ Nm
- ⑤ **Tightening torque:** $3,5\pm0,5$ Nm

Pin assignment: (see connection diagram)

Installation position: Shaft horizontal or rotor on bottom, rotor on top on request

B VBH0500PTTLS K3G500PA26C1 (EC centrifugal module with support bracket and PFC, active)

Dimensions in mm

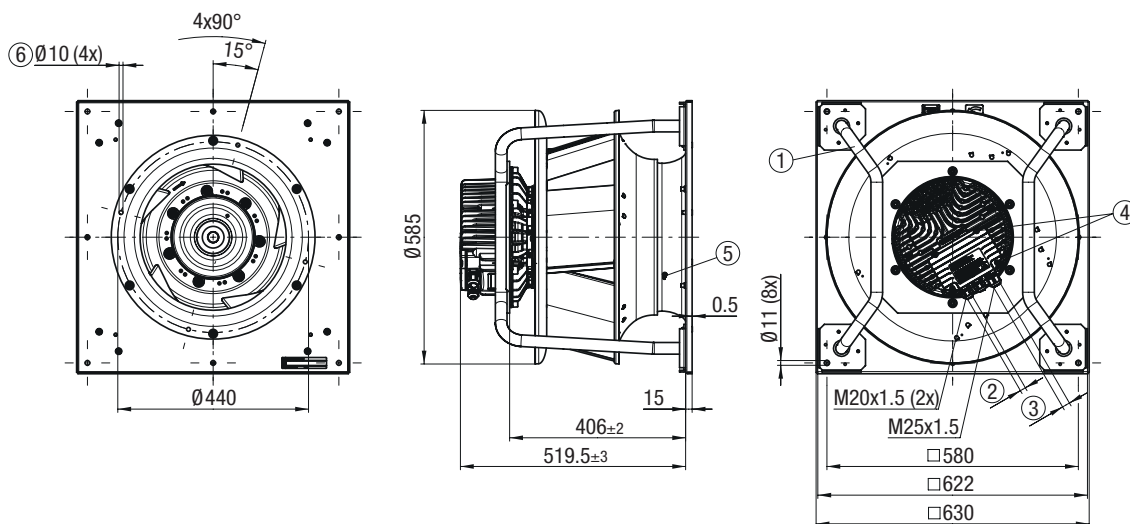

- ① **Installation position:** Shaft horizontal (Install support struts only vertically according to view!) or rotor on bottom, rotor on top on request
- ② **Cable diameter:** min. 4 mm, max. 10 mm, Tightening torque $4\pm0,6$ Nm
- ③ **Cable diameter:** min. 9 mm, max. 16 mm, Tightening torque $6\pm0,9$ Nm
- ④ **Tightening torque:** $3,5\pm0,5$ Nm
- ⑤ **Inlet ring:** with pressure tap (k-factor: 281)
- ⑥ **Mounting holes:** for FlowGrid

Pin assignment: (see connection diagram)

RadiPac 500

C VBS0500PTTLS R3G500PA2803 (EC centrifugal fan)

Dimensions in mm

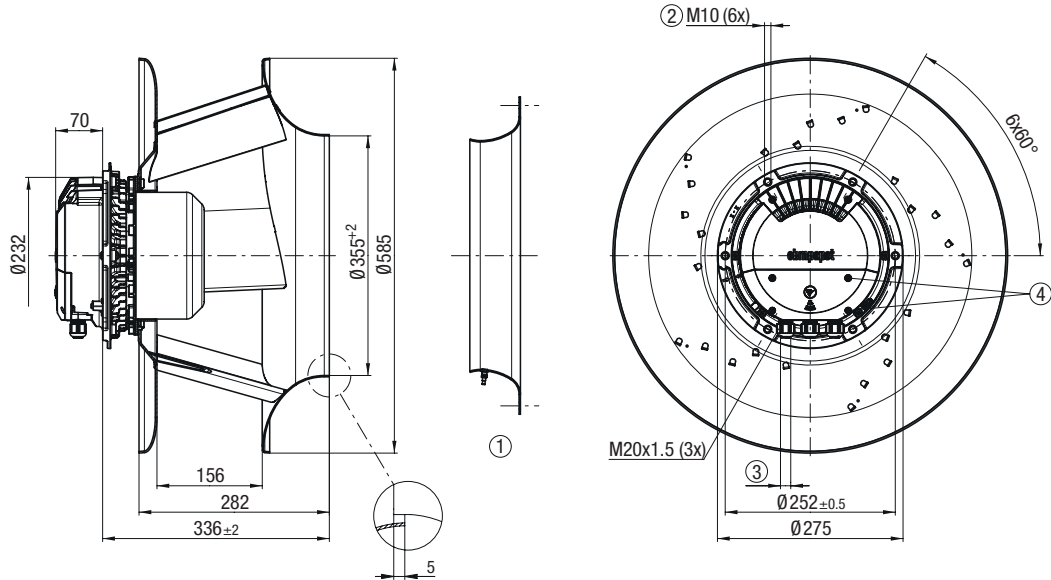

- ① Accessory part: Inlet ring 64025-2-4013 with pressure tap (k-factor: 281) not included in scope of delivery (Dimensions: see "Accessories" chapter)
- ② Max. clearance of screw: 20 mm
- ③ Cable diameter: min. 4 mm, max. 10 mm, Tightening torque $4 \pm 0,6$ Nm
- ④ Tightening torque: $1,5 \pm 0,2$ Nm

Pin assignment: (see connection diagram)

Installation position: Shaft horizontal or rotor on bottom, rotor on top on request

C VBH0500PTTLS K3G500PA2803 (EC centrifugal module with support bracket)

Dimensions in mm

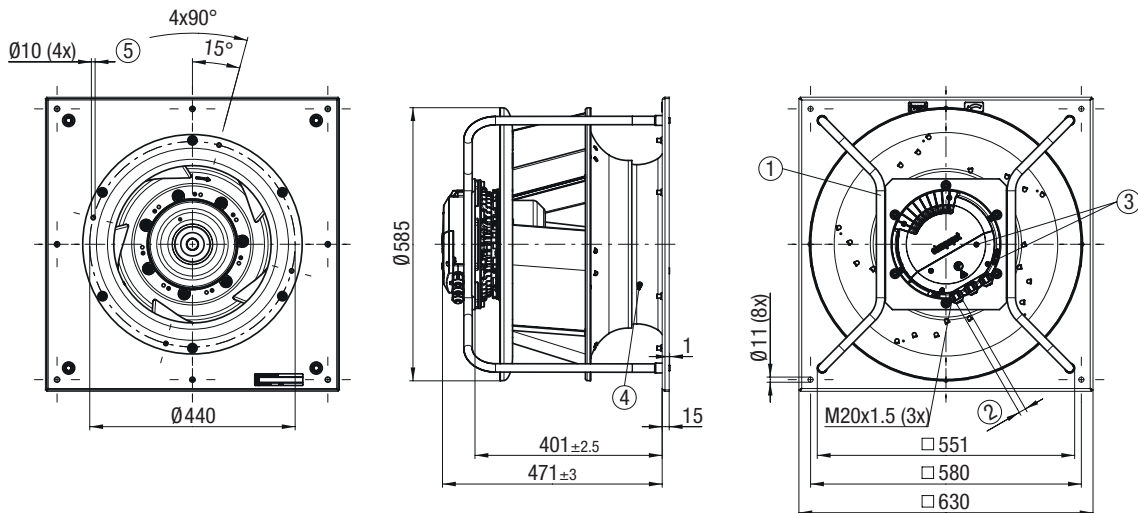

- ① Installation position: Shaft horizontal (Install support struts only vertically according to view!) or rotor on bottom, rotor on top on request
- ② Cable diameter: min. 4 mm, max. 10 mm, Tightening torque $4 \pm 0,6$ Nm
- ③ Tightening torque: $1,5 \pm 0,2$ Nm
- ④ Inlet ring: with pressure tap (k-factor: 281)
- ⑤ Mounting holes: for FlowGrid

Pin assignment: (see connection diagram)

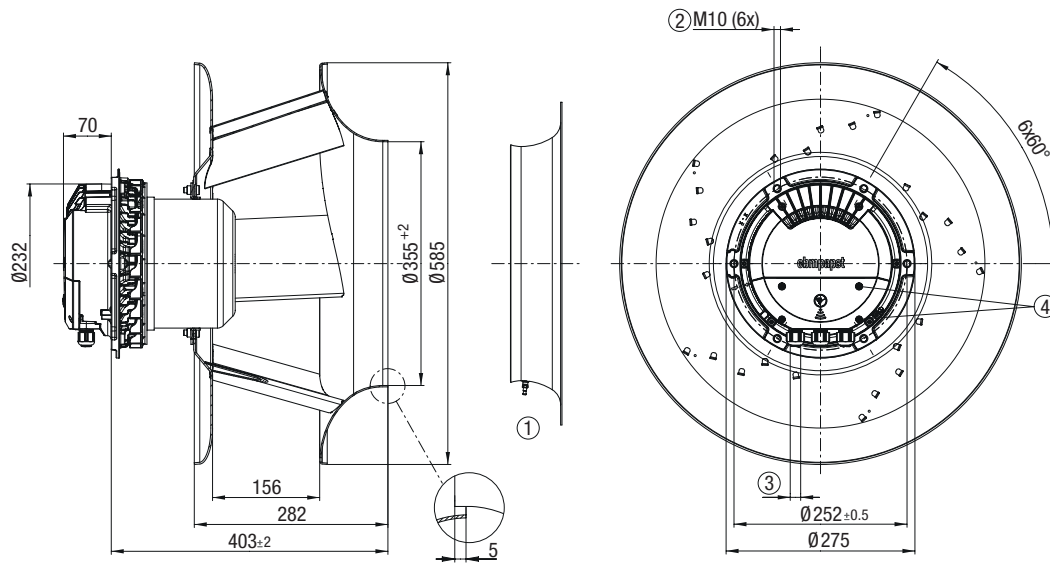

- ① **Accessory part:** Inlet ring 64025-2-4013 with pressure tap (k-factor: 281) not included in scope of delivery (Dimensions: see "Accessories" chapter)
- ② **Max. clearance of screw:** 20 mm
- ③ **Cable diameter:** min. 4 mm, max. 10 mm, Tightening torque $4 \pm 0,6$ Nm
- ④ **Tightening torque:** $1,5 \pm 0,2$ Nm

Pin assignment: (see connection diagram)

Installation position: Shaft horizontal or rotor on bottom, rotor on top on request

RadiPac 500

E VBS0500PTTTPS R3G500PB2403 & R3G500PB2465 (EC centrifugal fan)

Dimensions in mm

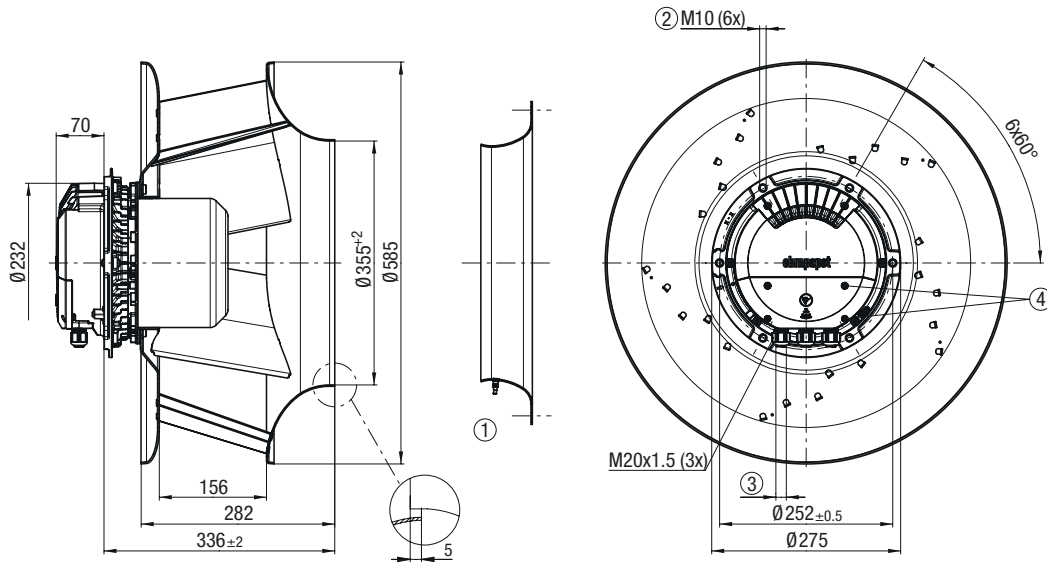

- ① **Accessory part:** Inlet ring 64025-2-4013 with pressure tap (k-factor: 281) not included in scope of delivery (Dimensions: see "Accessories" chapter)
- ② **Max. clearance of screw:** 20 mm
- ③ **Cable diameter:** min. 4 mm, max. 10 mm, Tightening torque 4±0,6 Nm
- ④ **Tightening torque:** 1,5±0,2 Nm

Pin assignment: (see connection diagram)
Installation position: Shaft horizontal or rotor on bottom, rotor on top on request

E VBH0500PTTTPS K3G500PB2403 (EC centrifugal module with support bracket)

Dimensions in mm

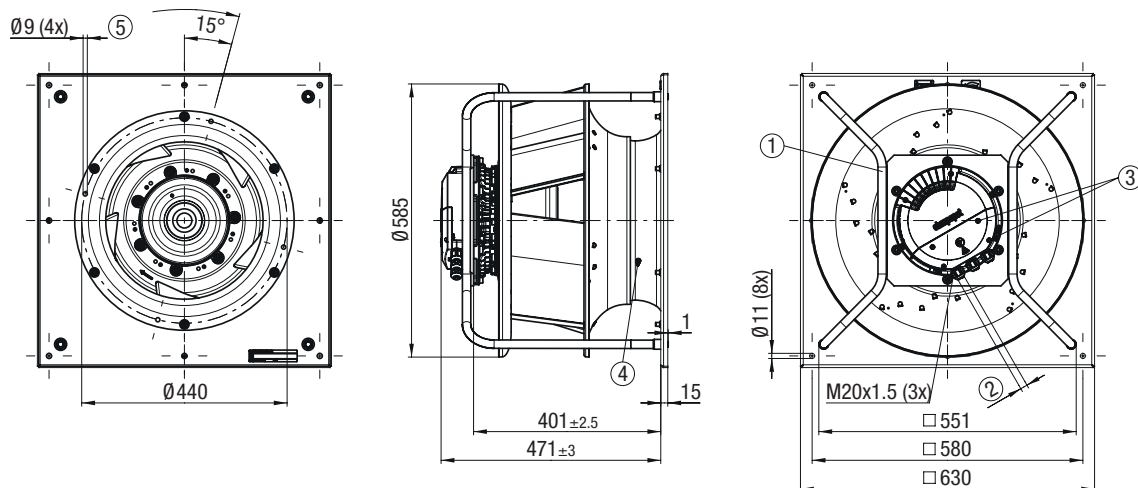

- ① **Installation position:** Shaft horizontal (Install support struts only vertically according to view!) or rotor on bottom, rotor on top on request
- ② **Cable diameter:** min. 4 mm, max. 10 mm, Tightening torque 4±0,6 Nm
- ③ **Tightening torque:** 1,5±0,2 Nm
- ④ **Inlet ring:** with pressure tap (k-factor: 281)
- ⑤ **Mounting holes:** for FlowGrid

Pin assignment: (see connection diagram)

E VBH0500PTTPS K3G500PB24W3 (EC centrifugal module with cube design / FanGrid)

Dimensions in mm

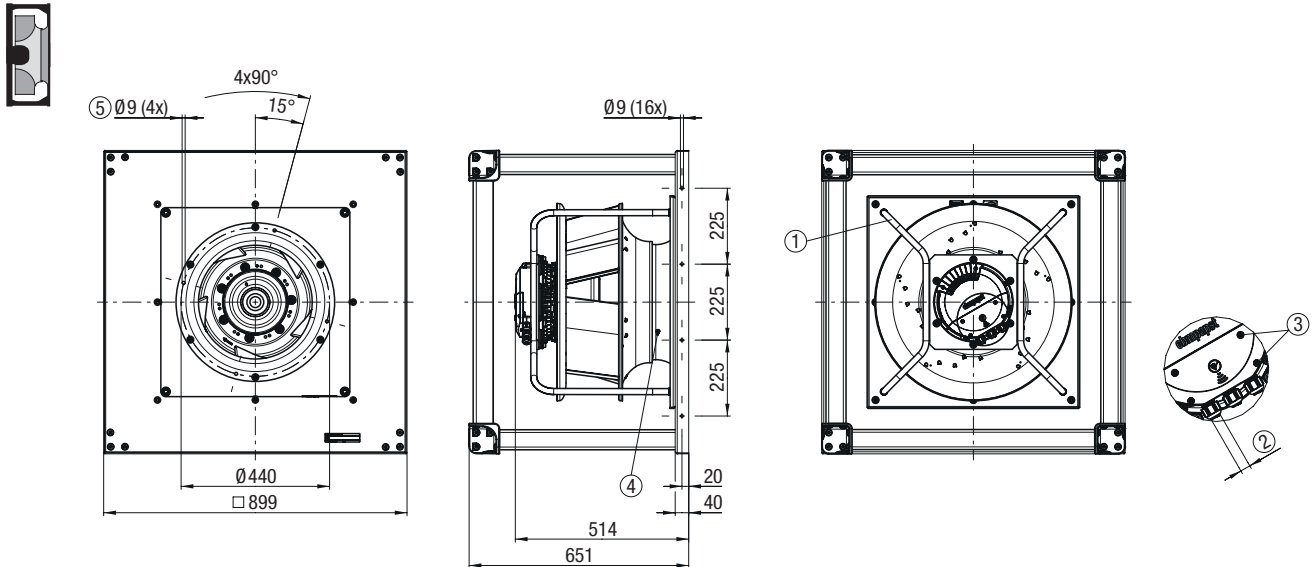

- ① **Installation position:** Shaft horizontal (Install support struts only vertically according to view!)
- ② **Cable gland M20 x 1.5:** Cable diameter min. 4 mm, max. 10 mm, Tightening torque 4 ± 0.6 Nm
- ③ **Tightening torque:** 1.5 ± 0.2 Nm
- ④ **Inlet ring:** with pressure tap (k-factor: 281)
- ⑤ **Mounting holes:** for FlowGrid

Pin assignment: (see connection diagram)

E VBH0500PTTPS K3G500PB24W5 (EC centrifugal module with cube design / FanGrid)

Dimensions in mm

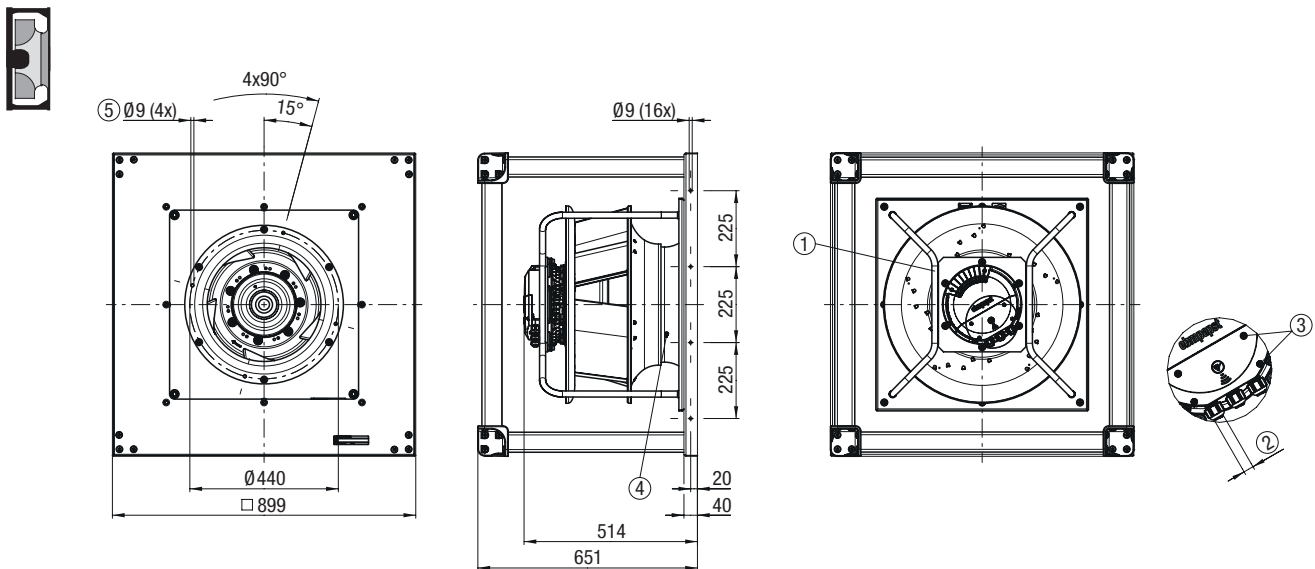

- ① **Installation position:** Shaft horizontal (Install support struts only vertically according to view!)
- ② **Cable gland M20 x 1.5:** Cable diameter min. 4 mm, max. 10 mm, Tightening torque 4 ± 0.6 Nm
- ③ **Tightening torque:** 1.5 ± 0.2 Nm
- ④ **Inlet ring:** with pressure tap (k-factor: 281)
- ⑤ **Mounting holes:** for FlowGrid

Pin assignment: (see connection diagram)

RadiPac 500

F VBS0500PTTRS R3G500PC16L1 (EC centrifugal fan)

Dimensions in mm

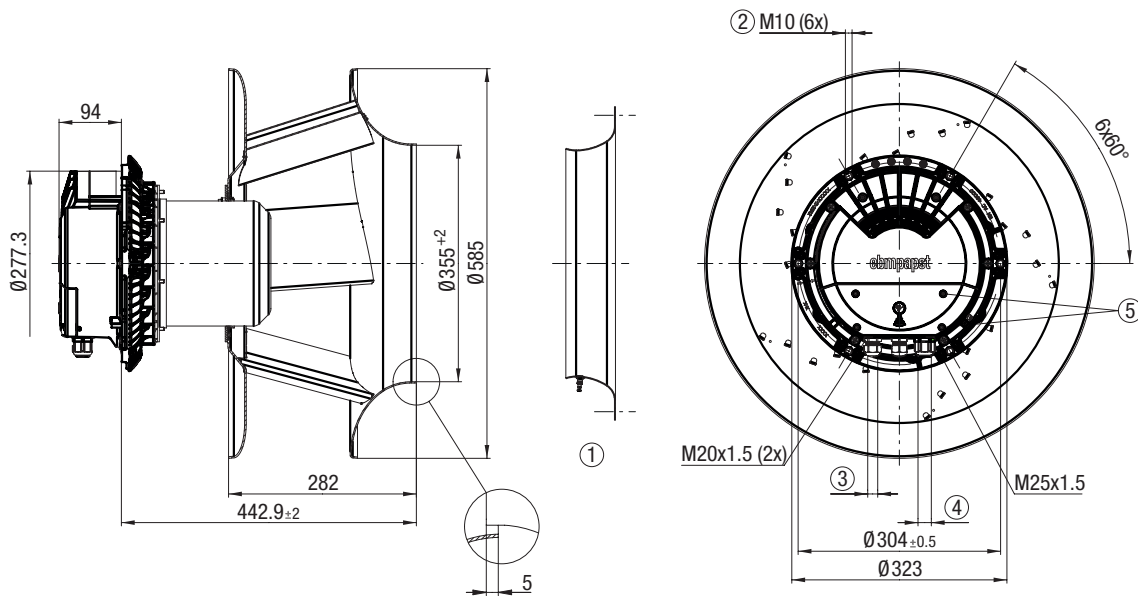

- ① Accessory part: Inlet ring 64025-2-4013 with pressure tap (k-factor: 281) not included in scope of delivery (Dimensions: see "Accessories" chapter)
- ② Max. clearance of screw: 20 mm
- ③ Cable diameter: min. 4 mm, max. 10 mm, Tightening torque $4 \pm 0,6$ Nm
- ④ Cable diameter: min. 5 mm, max. 14 mm, Tightening torque $6 \pm 0,9$ Nm
- ⑤ Tightening torque: $2,8 \pm 0,3$ Nm

Pin assignment: (see connection diagram)

Installation position: Shaft horizontal or rotor on bottom, rotor on top on request

F VBH0500PTTRS K3G500PC16L1 (EC centrifugal module with support bracket)

Dimensions in mm

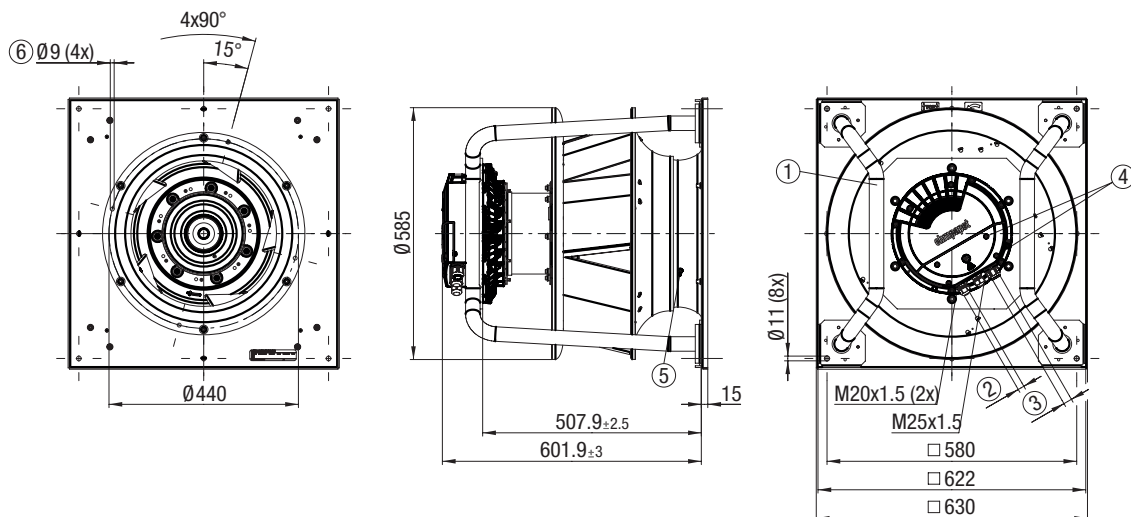

- ① Installation position: Shaft horizontal (Install support struts only vertically according to view!) or rotor on bottom, rotor on top on request
- ② Cable diameter: min. 4 mm, max. 10 mm, Tightening torque $4 \pm 0,6$ Nm
- ③ Cable diameter: min. 5 mm, max. 14 mm, Tightening torque $6 \pm 0,9$ Nm
- ④ Tightening torque: $2,8 \pm 0,3$ Nm
- ⑤ Inlet ring: with pressure tap (k-factor: 281)
- ⑥ Mounting holes: for FlowGrid

Pin assignment: (see connection diagram)

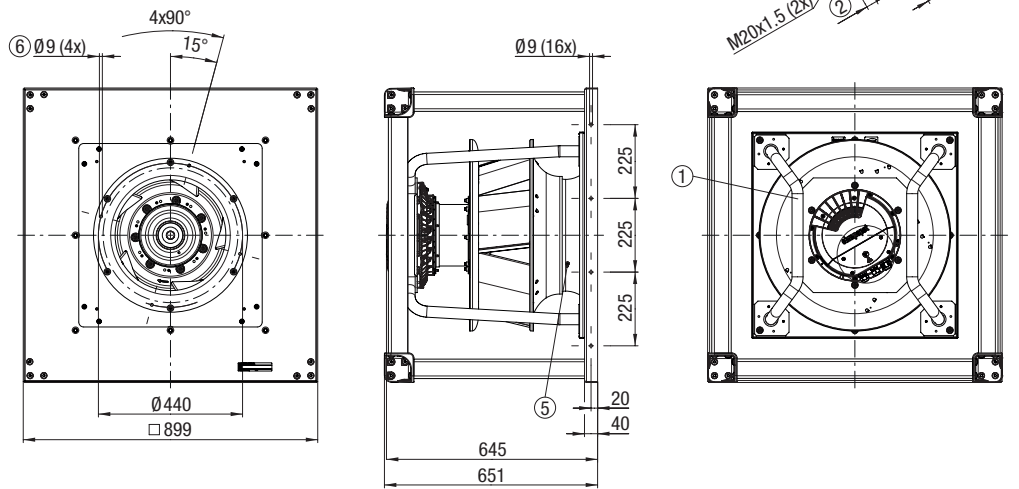

- ① **Installation position:** Shaft horizontal (Install support struts only vertically according to view!)
- ② **Cable diameter:** min. 4 mm, max. 10 mm, Tightening torque $4 \pm 0,6$ Nm
- ③ **Cable diameter:** min. 5 mm, max. 14 mm, Tightening torque $6 \pm 0,9$ Nm
- ④ **Tightening torque:** $2,8 \pm 0,3$ Nm
- ⑤ **Inlet ring:** with pressure tap (k-factor: 281)
- ⑥ **Mounting holes:** for FlowGrid

Pin assignment: (see connection diagram)

RadiPac 560

EC centrifugal fans, backward curved

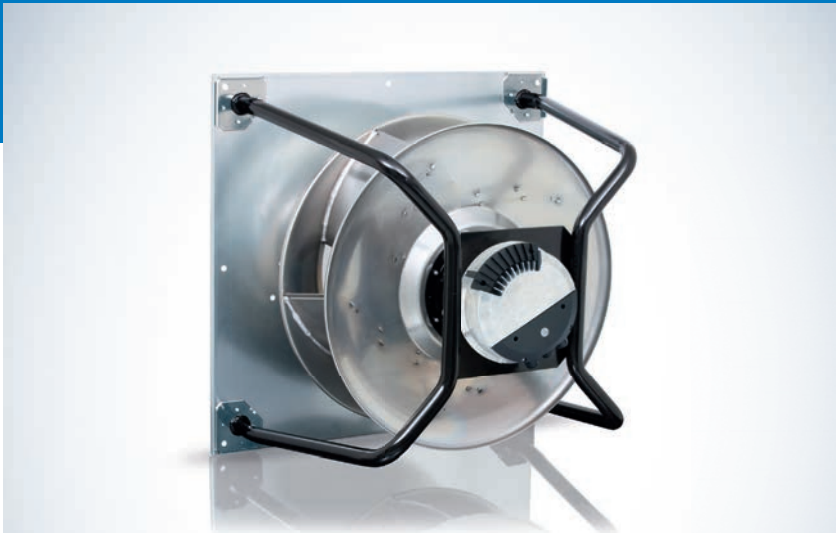

Material/surface

- Support bracket: Steel, painted black
- Support plate: Sheet steel, galvanized
- Spacer: aluminum
- Inlet ring: Sheet steel, galvanized
- Impeller: Sheet aluminum
- Rotor: Painted black
- Electronics housing: Die-cast aluminum

Mechanical characteristics

- Number of blades: 5
- Direction of rotation: Clockwise viewed toward rotor
- Installation position: See product drawing
- Condensation drainage holes: Rotor side
- Mode: Continuous operation (S1)
- Mounting: Maintenance-free ball bearings

Further Information





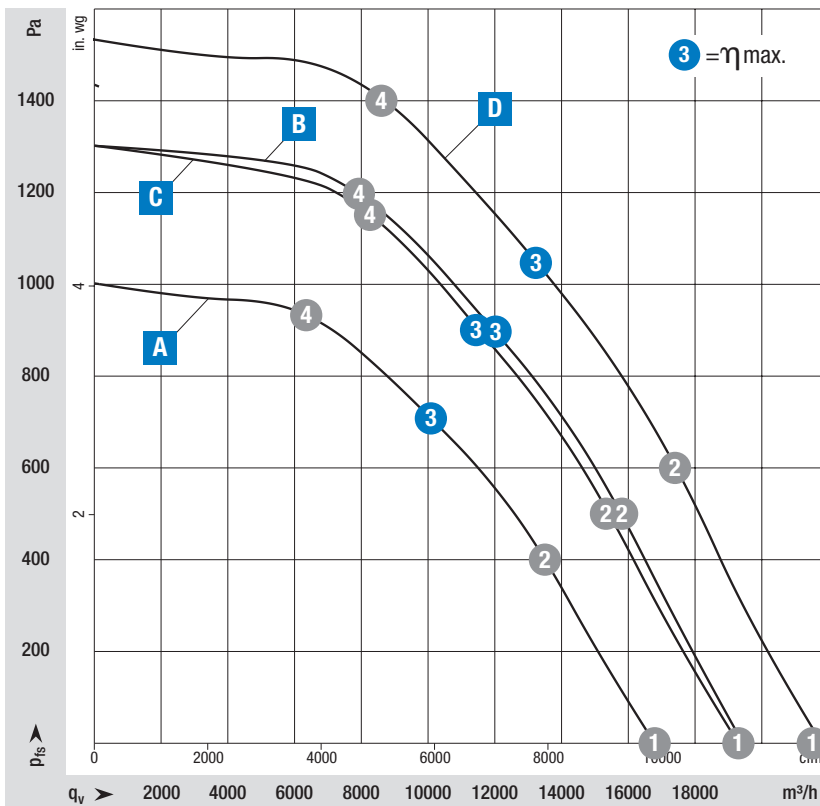







- Information about touch current, electrical connection, degree of protection, insulation class, environmental protection class, EMC standards as well as standards and approvals can be found in the product-specific data sheets.

on Page 82	Drawings
on Page 154	Accessories
on Page 166	Connection diagrams and technical features
on Page 172	Technical parameters & scope
More at	www.ebmpapst.com/worldwide www.ebmpapst.com/radipac



Measuring requirements

Air performance measured according to: ISO 5801, installation category A, with ebm-papst inlet ring without contact protection. Intake-side sound level: L_{wA} according to 13347, L_{wA} measured at 1 m distance from fan axis. The values given are only applicable under the specified measuring conditions and may differ depending on the installation conditions. In the event of deviation from the standard configuration, the parameters must be checked in installed condition.

Curve				Operating point	Nominal voltage	Speed n	Max. Input power P_{in}	Max. Input current I	Sound power level L _{WA}	Perm. ambient temp.	Degree of protection	Conn. diagram	
Nominal voltage range 3-380-480 V AC, 50/60 Hz				VAC	rpm	W	A	dB(A)	°C				
Type	Part number	Fan type											
A	VBS0560PTTPS	R3G560PB22C1	Centrifugal fan		PFC active	①	400	1470	1800	2,60	-25..+40	IP 55	RP1)
						②	400	1470	2710	3,94			
	③	400	1470	3060	4,40	79							
	④	400	1470	2830	4,10	83							
VBH0560PTTPS	K3G560PB22C1	Support bracket		PFC active									
B	VBS0560PTTPS	R3G560PB3102	Centrifugal fan			①	400	1700	2520	3,89	-40..+40	IP 55	RP4)
						②	400	1700	3830	5,84			
	③	400	1700	4400	6,60	84							
	④	400	1700	4270	6,50	87							
---	---	Support bracket											
C	VBS0560PTTPS	R3G560PB3103	Centrifugal fan										
	VBS0560PTTPS	R3G560PB3165	Centrifugal fan		Reso-nance-sensor								
	VBH0560PTTPS	K3G560PB3103	Support bracket			①	400	1700	2500	3,86	-40..+40	IP 55	RP4)
						②	400	1700	3765	5,74			
	③	400	1700	4250	6,50	82							
	④	400	1700	4070	6,20	85							
VBH0560PTTPS	K3G560PB31W3	Cube (FanGrid)											
VBH0560PTTPS	K3G560PB31W5	Cube (FanGrid)		Reso-nance-sensor									
D	VBS0560PTTRS	R3G560PC10L1	Centrifugal fan		Reso-nance-sensor								
	VBH0560PTTRS	K3G560PC10L1	Support bracket		Reso-nance-sensor	①	400	1860	3305	5,27	-40..+40	IP 55	RP4)
						②	400	1860	5135	7,95			
	③	400	1860	5950	9,20	86							
④	400	1860	5620	8,67	90								
VBH0560PTTRS	K3G560PC10N3	Cube (FanGrid)		Reso-nance-sensor									

Subject to change

Values set in blue are nominal data at operating point with maximum load.

RadiPac 560

A VBS0560PTTPS R3G560PB22C1 (EC centrifugal fan with PFC, active)

Dimensions in mm

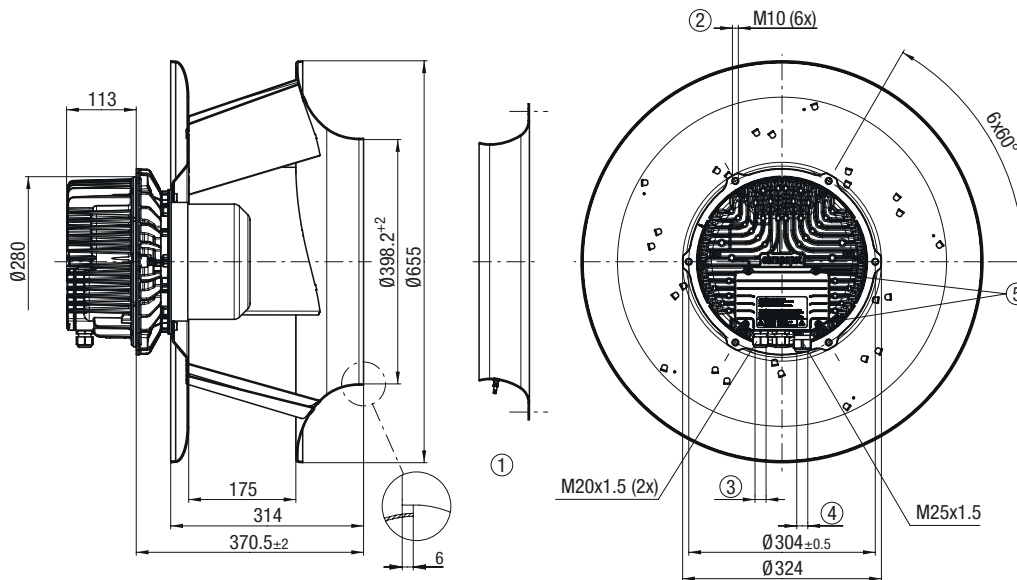

- ① **Accessory part:** Inlet ring 64030-2-4013 with pressure tap (k-factor: 348) not included in scope of delivery (Dimensions: see "Accessories" chapter)
- ② **Max. clearance of screw:** 20 mm
- ③ **Cable diameter:** min. 4 mm, max. 10 mm, Tightening torque $4 \pm 0,6$ Nm
- ④ **Cable diameter:** min. 9 mm, max. 16 mm, Tightening torque $6 \pm 0,9$ Nm
- ⑤ **Tightening torque:** $3,5 \pm 0,5$ Nm

Pin assignment: (see connection diagram)

Installation position: Shaft horizontal or rotor on bottom, rotor on top on request

A VBH0560PTTPS K3G560PB22C1 (EC centrifugal module with support bracket and PFC, active)

Dimensions in mm

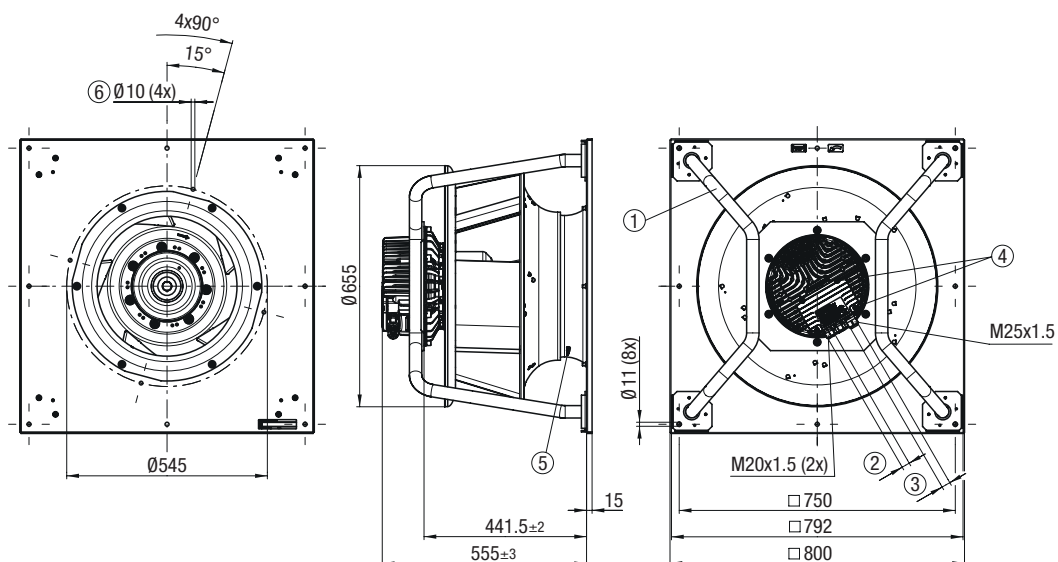

- ① **Installation position:** Shaft horizontal (Install support struts only vertically according to view!) or rotor on bottom, rotor on top on request
- ② **Cable diameter:** min. 4 mm, max. 10 mm, Tightening torque $4 \pm 0,6$ Nm
- ③ **Cable diameter:** min. 9 mm, max. 16 mm, Tightening torque $6 \pm 0,9$ Nm
- ④ **Tightening torque:** $3,5 \pm 0,5$ Nm
- ⑤ **Inlet ring:** with pressure tap (k-factor: 348)
- ⑥ **Mounting holes:** for FlowGrid

Pin assignment: (see connection diagram)

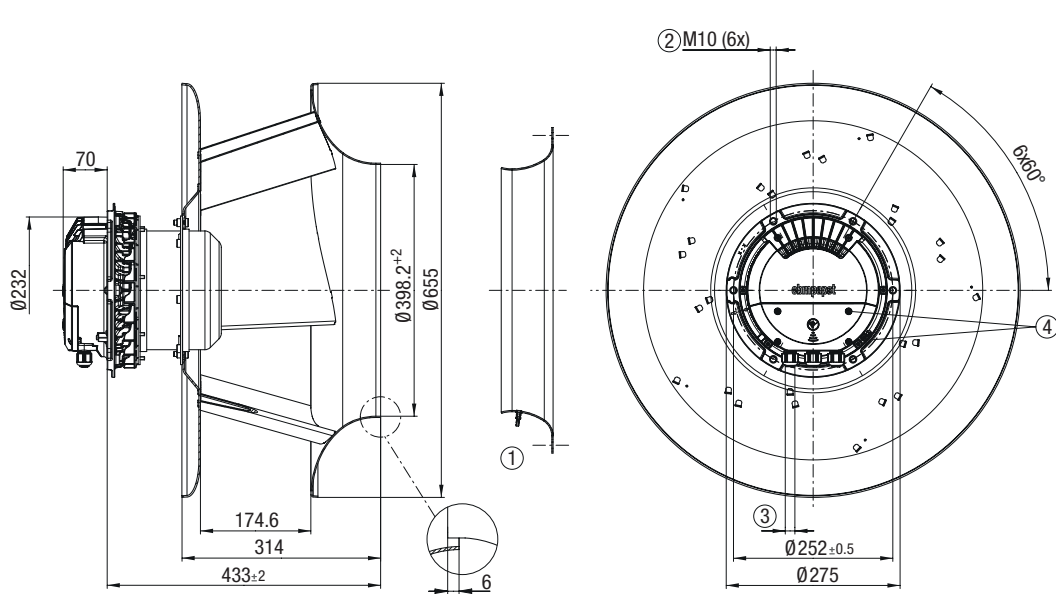

- ① **Accessory part:** Inlet ring 64030-2-4013 with pressure tap (k-factor: 348) not included in scope of delivery (Dimensions: see "Accessories" chapter)
- ② **Max. clearance of screw:** 20 mm
- ③ **Cable diameter:** min. 4 mm, max. 10 mm, Tightening torque $4 \pm 0,6$ Nm
- ④ **Tightening torque:** $1,5 \pm 0,2$ Nm

Pin assignment: (see connection diagram)

Installation position: Shaft horizontal or rotor on bottom, rotor on top on request

RadiPac 560

C VBS0560PTTPS R3G560PB3103 & R3G560PB3165 (EC centrifugal fan)

Dimensions in mm

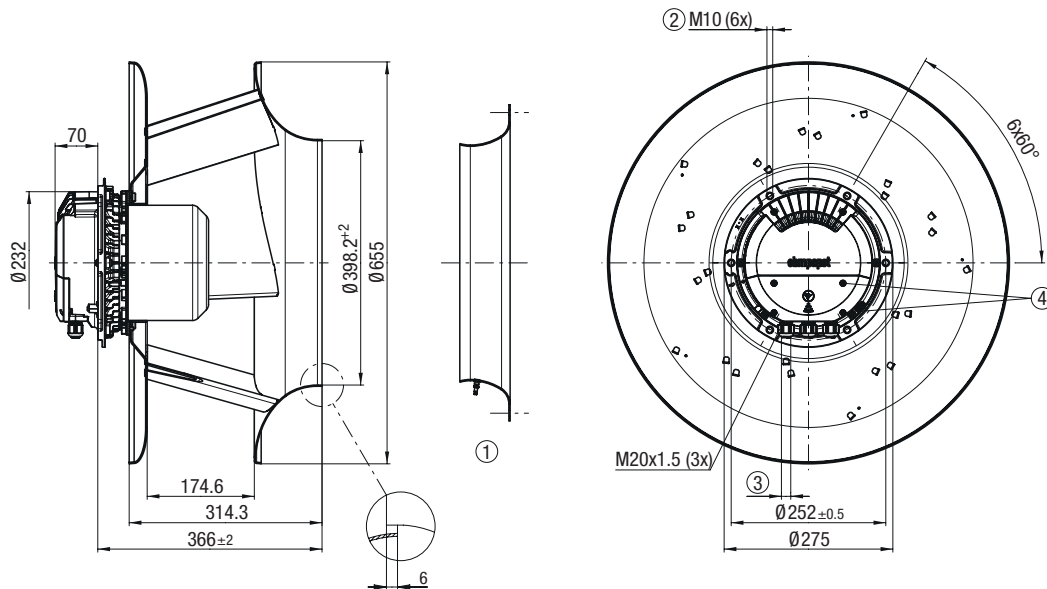

- ① **Accessory part:** Inlet ring 64030-2-4013 with pressure tap (k-factor: 348) not included in scope of delivery (Dimensions: see "Accessories" chapter)
- ② **Max. clearance of screw:** 20 mm
- ③ **Cable diameter:** min. 4 mm, max. 10 mm, Tightening torque 4±0,6 Nm
- ④ **Tightening torque:** 1,5±0,2 Nm

Pin assignment: (see connection diagram)
Installation position: Shaft horizontal or rotor on bottom, rotor on top on request

C VBH0560PTTPS K3G560PB3103 (EC centrifugal module with support bracket)

Dimensions in mm

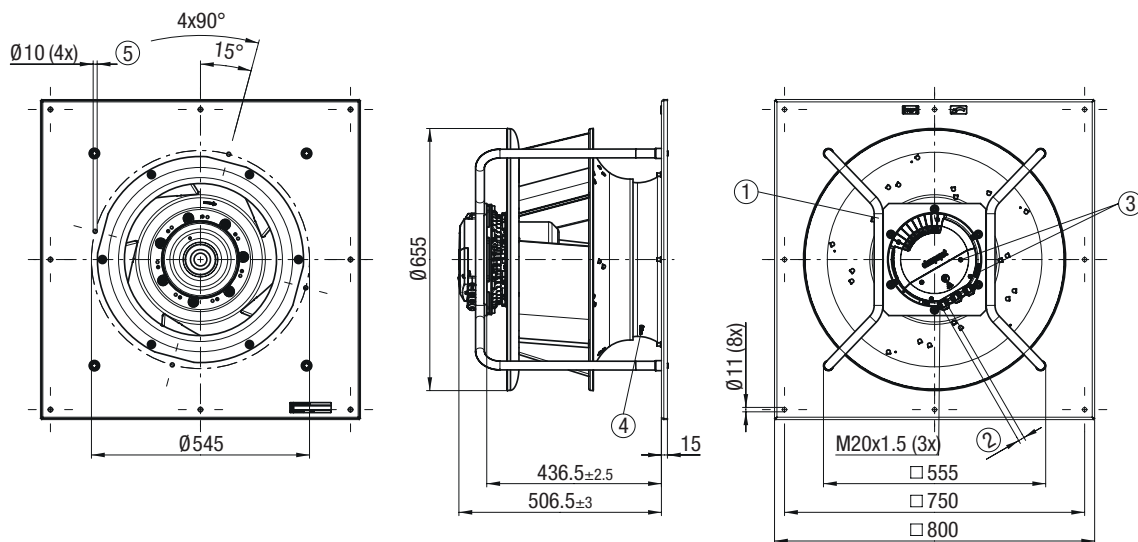

- ① **Installation position:** Shaft horizontal (Install support struts only vertically according to view!) or rotor on bottom, rotor on top on request
- ② **Cable diameter:** min. 4 mm, max. 10 mm, Tightening torque 4±0,6 Nm
- ③ **Tightening torque:** 1,5±0,2 Nm
- ④ **Inlet ring:** with pressure tap (k-factor: 348)
- ⑤ **Mounting holes:** for FlowGrid

Pin assignment: (see connection diagram)

C VBH0560PTTPS K3G560PB31W3 (EC centrifugal module with cube design / FanGrid)

Dimensions in mm

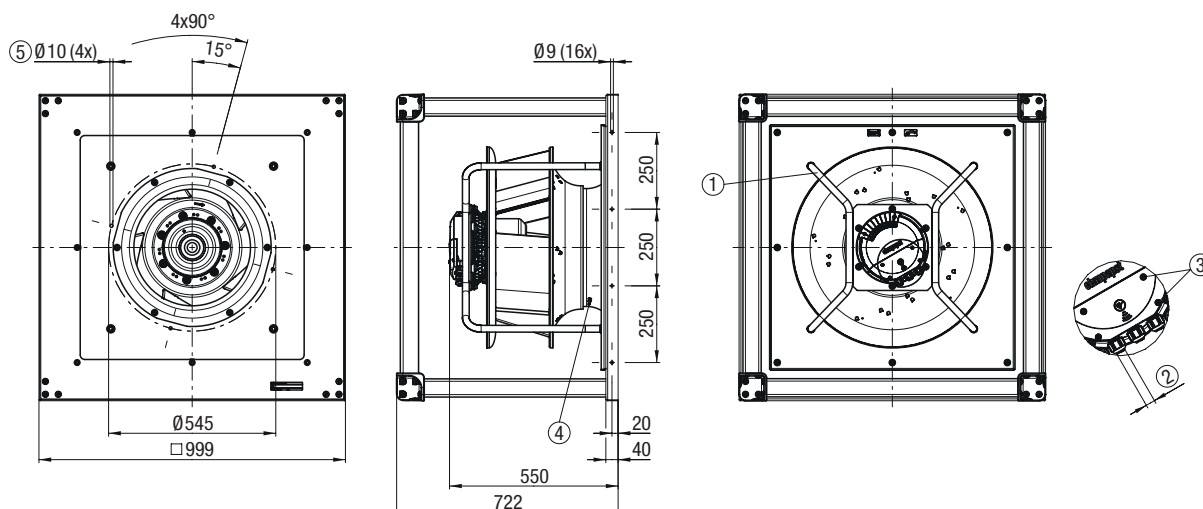

- ① **Installation position:** Shaft horizontal (Install support struts only vertically according to view!)
- ② **Cable gland M20 x 1.5:** Cable diameter min. 4 mm, max. 10 mm, Tightening torque 4 ± 0.6 Nm
- ③ **Tightening torque:** 1.5 ± 0.2 Nm
- ④ **Inlet ring:** with pressure tap (k-factor: 348)
- ⑤ **Mounting holes:** for FlowGrid

Pin assignment: (see connection diagram)

C VBH0560PTTPS K3G560PB31W5 (EC centrifugal module with cube design / FanGrid)

Dimensions in mm

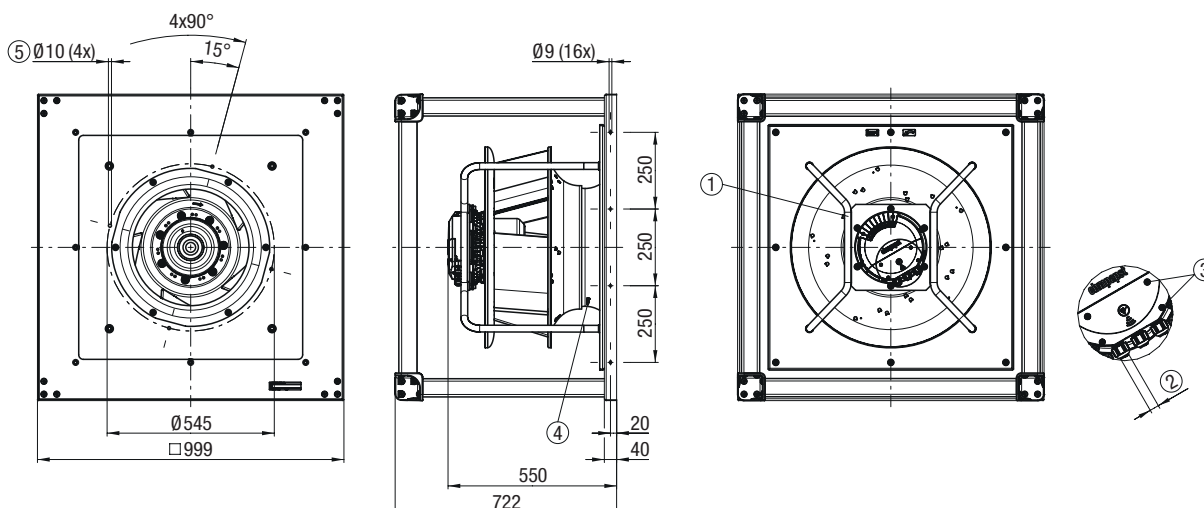

- ① **Installation position:** Shaft horizontal (Install support struts only vertically according to view!)
- ② **Cable gland M20 x 1.5:** Cable diameter min. 4 mm, max. 10 mm, Tightening torque 4 ± 0.6 Nm
- ③ **Tightening torque:** 1.5 ± 0.2 Nm
- ④ **Inlet ring:** with pressure tap (k-factor: 348)
- ⑤ **Mounting holes:** for FlowGrid

Pin assignment: (see connection diagram)

RadiPac 560

D VBS0560PTTRS R3G560PC10L1 (EC centrifugal fan)

Dimensions in mm

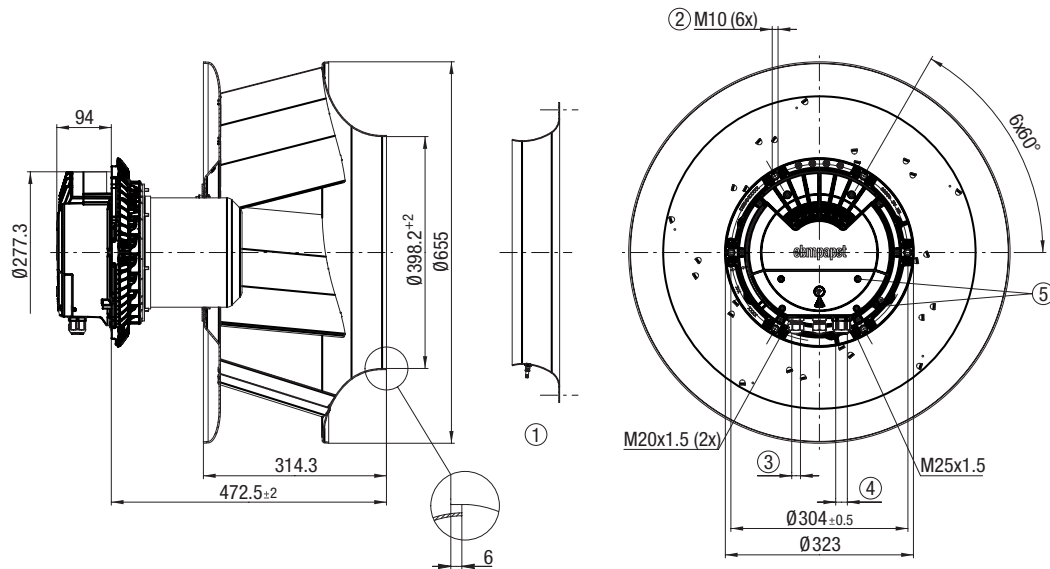

- ① **Accessory part:** Inlet ring 64030-2-4013 with pressure tap (k-factor: 348) not included in scope of delivery (Dimensions: see "Accessories" chapter)
- ② **Max. clearance of screw:** 20 mm
- ③ **Cable diameter:** min. 4 mm, max. 10 mm, Tightening torque 4±0,6 Nm
- ④ **Cable diameter:** min. 5 mm, max. 14 mm, Tightening torque 6±0,9 Nm
- ⑤ **Tightening torque:** 2,8±0,3 Nm

Pin assignment: (see connection diagram)
Installation position: Shaft horizontal or rotor on bottom, rotor on top on request

D VBH0560PTTRS K3G560PC10L1 (EC centrifugal module with support bracket)

Dimensions in mm

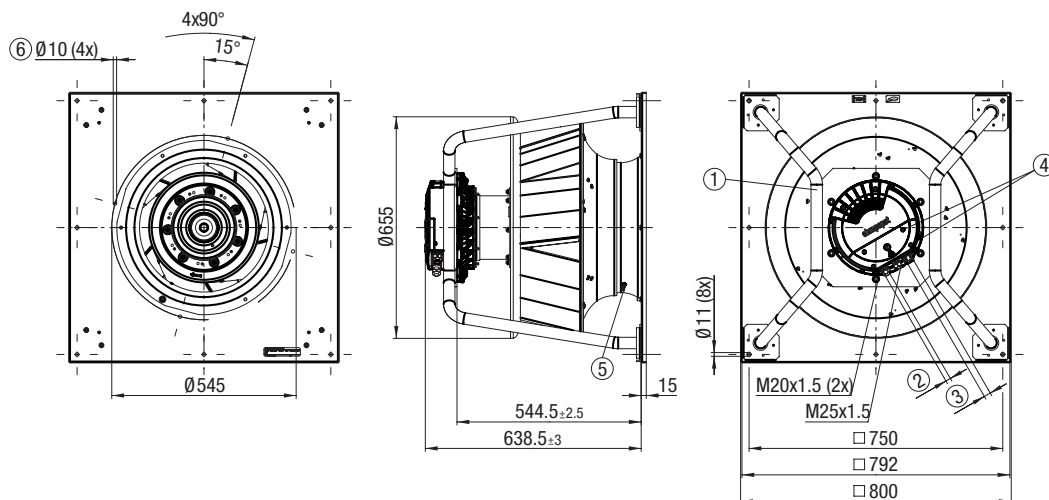

- ① **Installation position:** Shaft horizontal (Install support struts only vertically according to view!) or rotor on bottom, rotor on top on request
- ② **Cable diameter:** min. 4 mm, max. 10 mm, Tightening torque 4±0,6 Nm
- ③ **Cable diameter:** min. 5 mm, max. 14 mm, Tightening torque 6±0,9 Nm
- ④ **Tightening torque:** 2,8±0,3 Nm
- ⑤ **Inlet ring:** with pressure tap (k-factor: 348)
- ⑥ **Mounting holes:** for FlowGrid

Pin assignment: (see connection diagram)

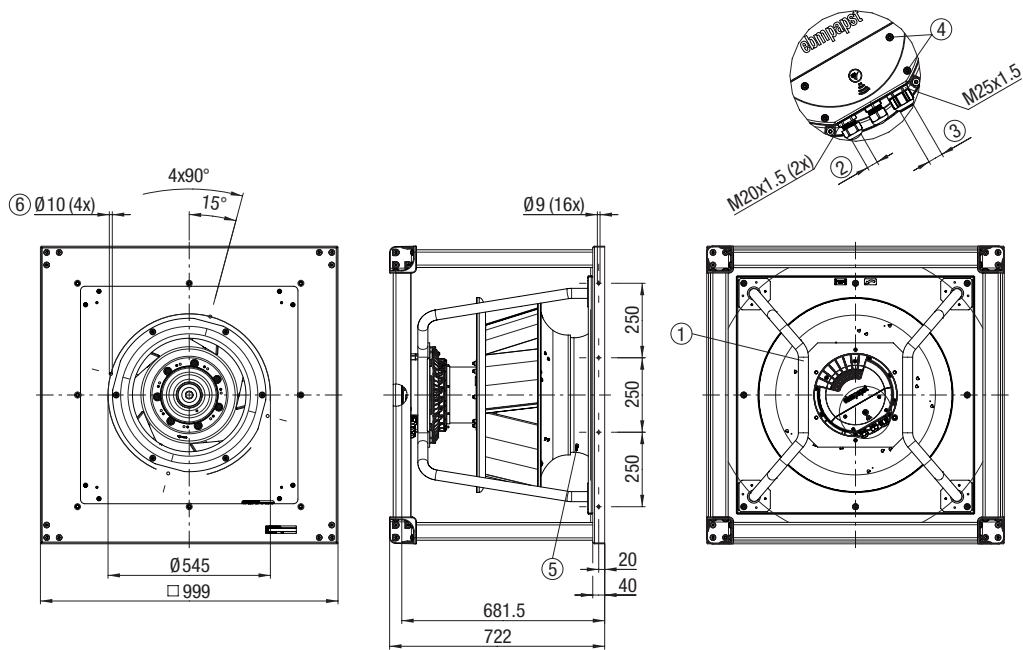

- ① **Installation position:** Shaft horizontal (Install support struts only vertically according to view!)
- ② **Cable diameter:** min. 4 mm, max. 10 mm, Tightening torque $4 \pm 0,6$ Nm
- ③ **Cable diameter:** min. 5 mm, max. 14 mm, Tightening torque $6 \pm 0,9$ Nm
- ④ **Tightening torque:** $2,8 \pm 0,3$ Nm
- ⑤ **Inlet ring:** with pressure tap (k-factor: 348)
- ⑥ **Mounting holes:** for FlowGrid

Pin assignment: (see connection diagram)

RadiPac 630

EC centrifugal fans, backward curved



Material/surface

- Support bracket: Steel, painted black
- Support plate: Sheet steel, galvanized
- Spacer: aluminum
- Inlet ring: Sheet steel, galvanized
- Impeller: Sheet aluminum
- Rotor: Painted black
- Electronics housing: Die-cast aluminum

Mechanical characteristics

- Number of blades: 5
- Direction of rotation: Clockwise viewed toward rotor
- Installation position: See product drawing
- Condensation drainage holes: Rotor side
- Mode: Continuous operation (S1)
- Mounting: Maintenance-free ball bearings

Further Information





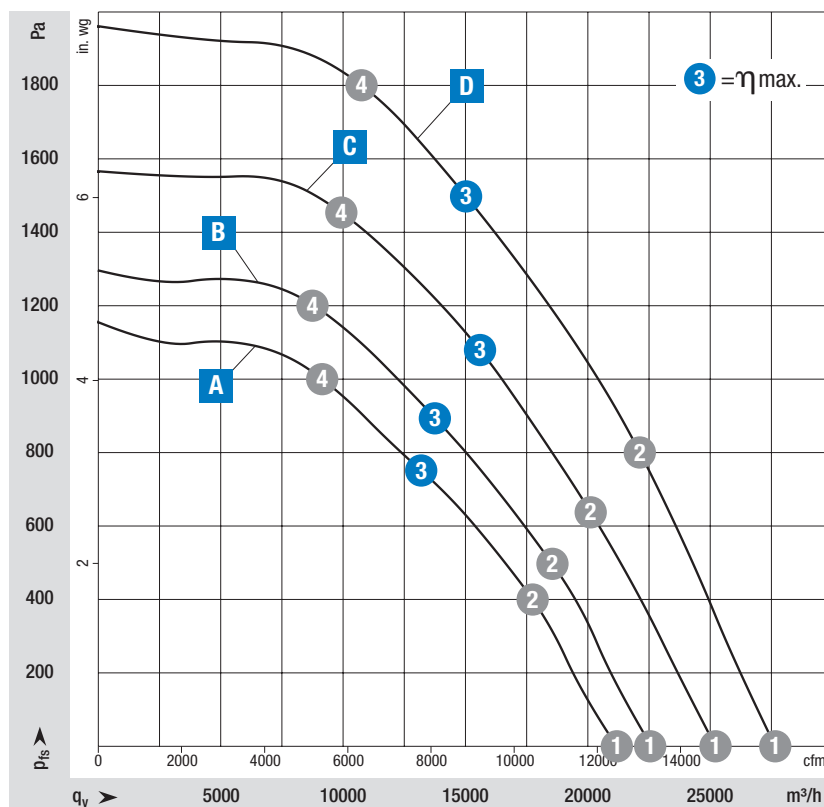

- Information about touch current, electrical connection, degree of protection, insulation class, environmental protection class, EMC standards as well as standards and approvals can be found in the product-specific data sheets.

on Page 90	Drawings
on Page 154	Accessories
on Page 166	Connection diagrams and technical features
on Page 172	Technical parameters & scope
More at	www.ebmpapst.com/worldwide www.ebmpapst.com/radipac



Measuring requirements

Air performance measured according to: ISO 5801, installation category A, with ebm-papst inlet ring without contact protection. Intake-side sound level: L_{wA} according to 13347, L_{wA} measured at 1 m distance from fan axis. The values given are only applicable under the specified measuring conditions and may differ depending on the installation conditions. In the event of deviation from the standard configuration, the parameters must be checked in installed condition.

Curve				Operating point	Nominal voltage	Speed n	Max. Input power P _{in}	Max. Input current I	Sound power level L _{WA}	Perm. ambient temp.	Degree of protection	Conn. diagram		
Nominal voltage range 3-380-480 V AC, 50/60 Hz													VAC	rpm
Type	Part number	Fan type												
A	VBS0630PTTRS	R3G630PC0803	Centrifugal fan		①	400	1500	2295	3,65	93	-40..+40	IP 55	RP4)	
					②	400	1500	3520	5,38	86				
	③	400	1500	4250	6,50	82								
	④	400	1500	4165	6,33	84								
B	VBS0630PTTRS	R3G630PC04L1	Centrifugal fan		Reso-nance-sensor	①	400	1610	2770	4,50	93	-40..+40	IP 55	RP4)
						②	400	1610	4405	6,88	86			
	③	400	1610	5250	8,10	83								
	④	400	1610	5030	7,80	87								
C	---	---	Centrifugal fan			①	400	1750	3735	5,89	99	-40..+40	IP 55	RP1)
						②	400	1750	6000	9,22	90			
	③	400	1750	7060	10,80	86								
	④	400	1750	6900	10,55	89								
D	---	---	Centrifugal fan			①	400	1950	5080	8,40	105	-40..+40	IP 55	RP1)
						②	400	1950	8400	13,19	96			
	③	400	1950	9780	15,20	89								
	④	400	1950	9330	14,55	94								
	VBF0630PTVNS	K3G630PV0401	Cube			③	400	1750	7060	10,80	86	-40..+40	IP 55	RP1)
						④	400	1750	6900	10,55	89			
	VBF0630PTVQS	K3G630PW0401	Cube			③	400	1950	9780	15,20	89	-40..+40	IP 55	RP1)
						④	400	1950	9330	14,55	94			

Subject to change

Values set in blue are nominal data at operating point with maximum load.

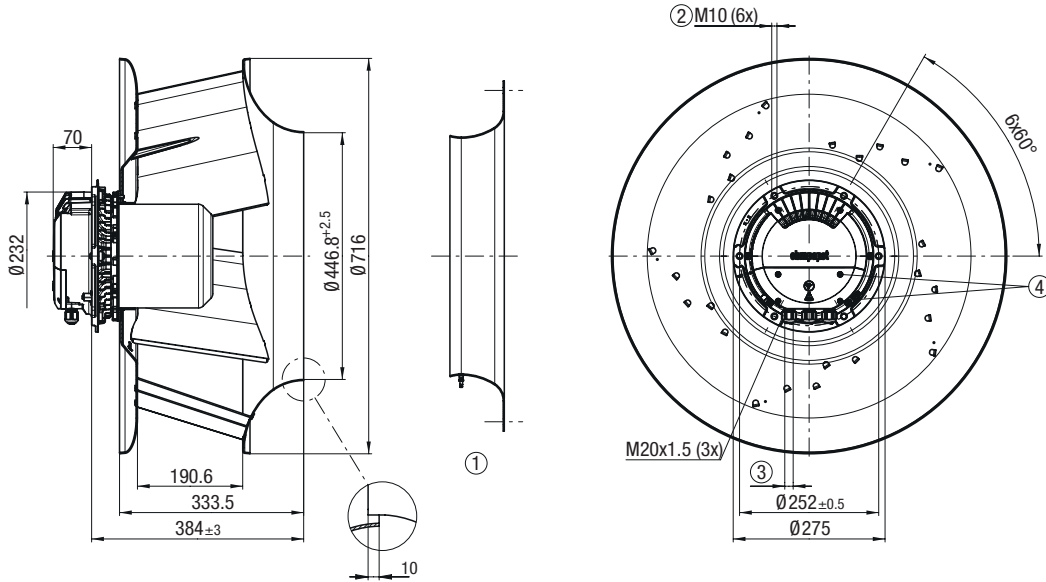

- ① Accessory part: Inlet ring 64045-2-4013 with pressure tap (k-factor: 438) not included in scope of delivery (Dimensions: see "Accessories" chapter)
- ② Max. clearance of screw: 20 mm
- ③ Cable diameter: min. 4 mm, max. 10 mm, Tightening torque $4 \pm 0,6$ Nm
- ④ Tightening torque: $1,5 \pm 0,2$ Nm

Pin assignment: (see connection diagram)

Installation position: Shaft horizontal or rotor on bottom, rotor on top on request

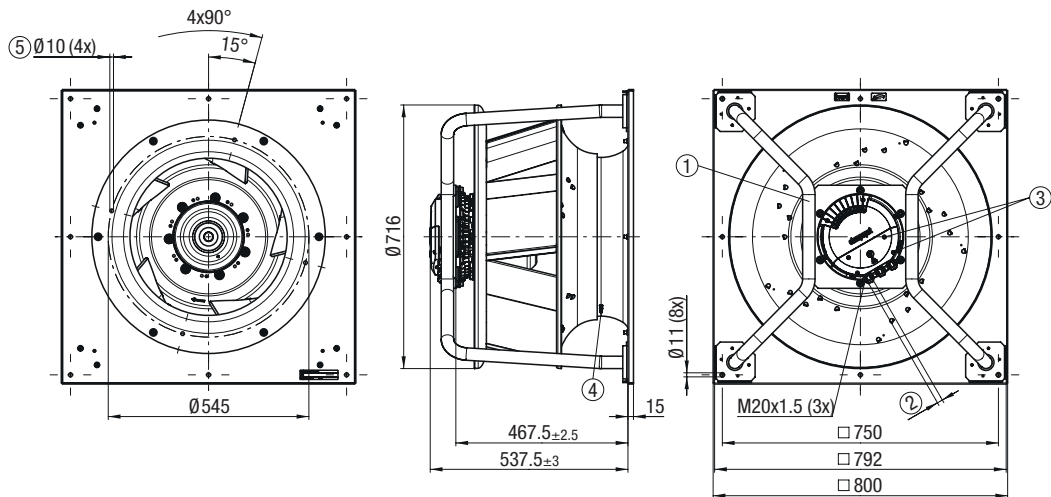

- ① Installation position: Shaft horizontal (Install support struts only vertically according to view!) or rotor on bottom, rotor on top on request
- ② Cable diameter: min. 4 mm, max. 10 mm, Tightening torque $4 \pm 0,6$ Nm
- ③ Tightening torque: $1,5 \pm 0,2$ Nm
- ④ Inlet ring: with pressure tap (k-factor: 438)
- ⑤ Mounting holes: for FlowGrid

Pin assignment: (see connection diagram)

B VBS0630PTTRS R3G630PC04L1 (EC centrifugal fan)

Dimensions in mm

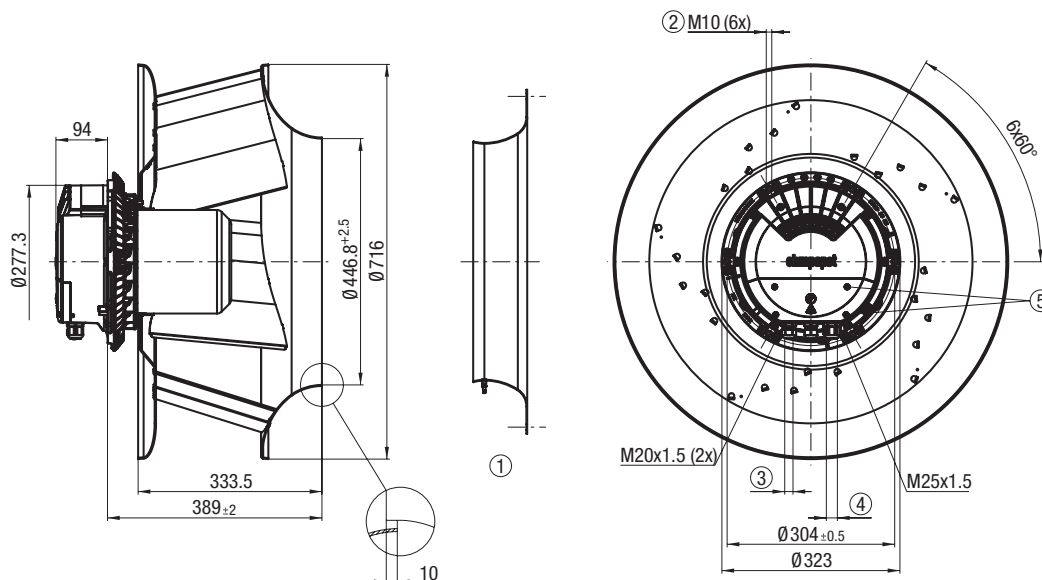

- ① **Accessory part:** Inlet ring 64040-2-4013 with pressure tap (k-factor: 438) not included in scope of delivery (Dimensions: see "Accessories" chapter)
- ② **Max. clearance of screw:** 20 mm
- ③ **Cable diameter:** min. 4 mm, max. 10 mm, Tightening torque $4 \pm 0,6$ Nm
- ④ **Cable diameter:** min. 5 mm, max. 14 mm, Tightening torque $6 \pm 0,9$ Nm
- ⑤ **Tightening torque:** $2,8 \pm 0,3$ Nm

Pin assignment: (see connection diagram)
Installation position: Shaft horizontal or rotor on bottom, rotor on top on request

B VBH0630PTTRS K3G630PC04L1 (EC centrifugal module with support bracket)

Dimensions in mm

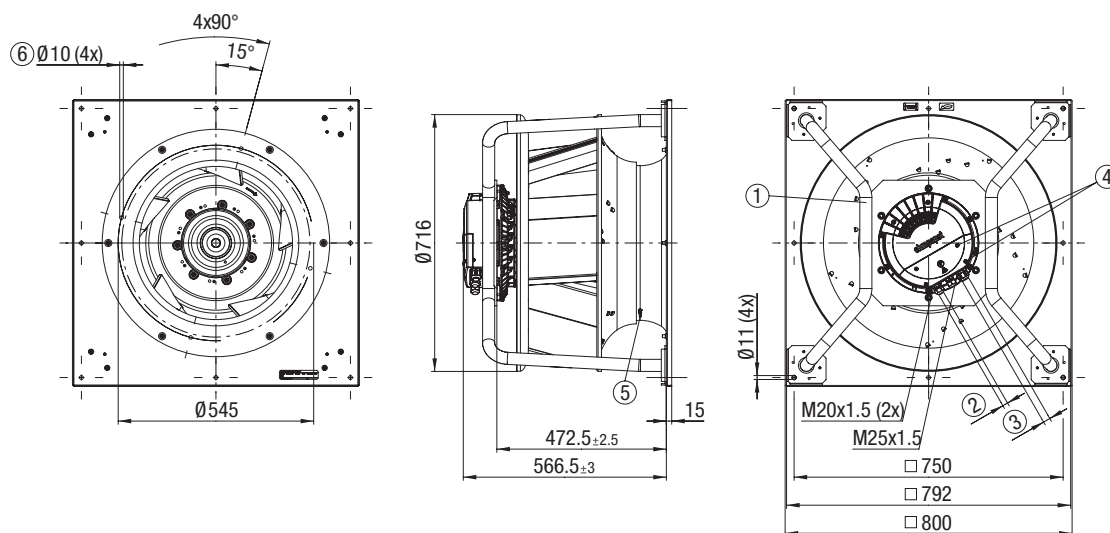

- ① **Installation position:** Shaft horizontal (Install support struts only vertically according to view!) or rotor on bottom, rotor on top on request
- ② **Cable diameter:** min. 4 mm, max. 10 mm, Tightening torque $4 \pm 0,6$ Nm
- ③ **Cable diameter:** min. 5 mm, max. 14 mm, Tightening torque $6 \pm 0,9$ Nm
- ④ **Tightening torque:** $2,8 \pm 0,3$ Nm
- ⑤ **Inlet ring:** with pressure tap (k-factor: 438)
- ⑥ **Mounting holes:** for FlowGrid

Pin assignment: (see connection diagram)

RadiPac 630

C VBF0630PTVNS K3G630PV0401 (EC centrifugal module with cube design)

Dimensions in mm

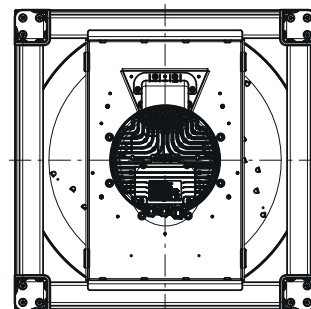
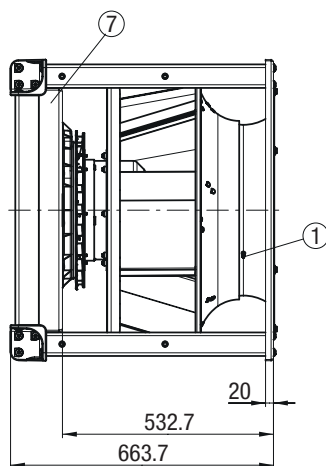
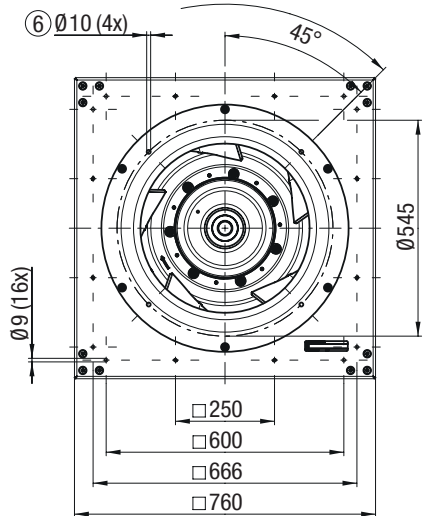
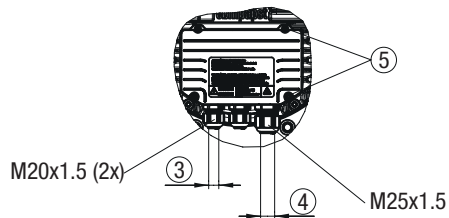
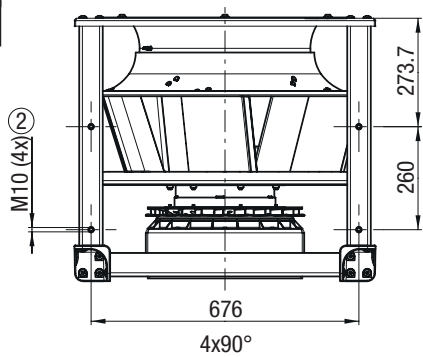

- ① Inlet ring: with pressure tap (k-factor: 438)
- ② Mounting position for vibration-absorbing elements: Tightening torque 40 Nm
- ③ Cable gland: Cable diameter min. 5 mm, max. 13 mm, Tightening torque 4 ± 0.6 Nm
- ④ Cable gland: Cable diameter min. 16 mm, max. 20.5 mm, Tightening torque 6 ± 0.9 Nm
- ⑤ Tightening torque: 3.5 ± 0.5 Nm
- ⑥ Mounting holes: for FlowGrid
- ⑦ Installation position: Shaft horizontal (motor support plate must stand upright!) or rotor on bottom, rotor on top on request!

Pin assignment: (see connection diagram)

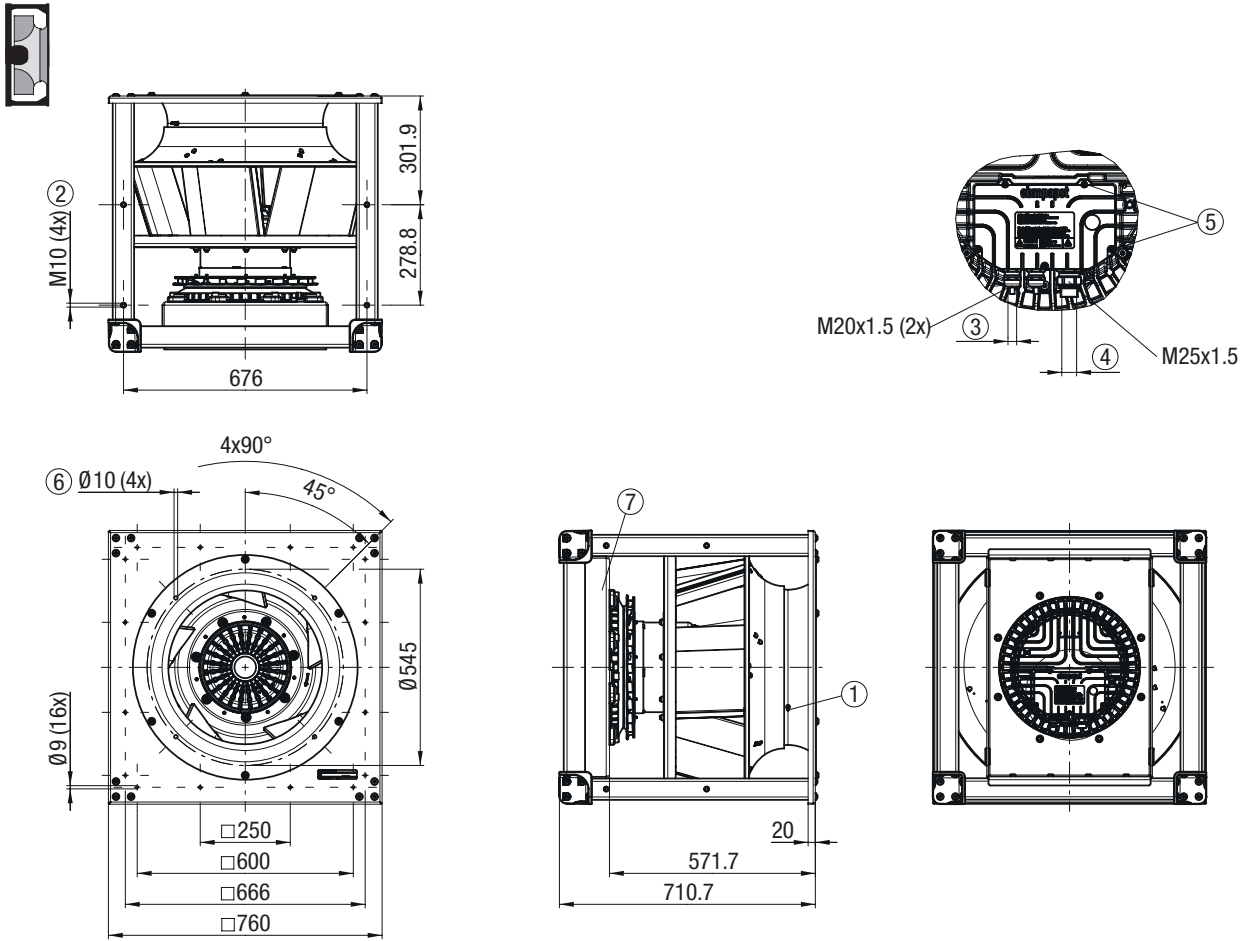

- ① Inlet ring: with pressure tap (k-factor: 438)
- ② Mounting position for vibration-absorbing elements: Tightening torque 40 Nm
- ③ Cable gland: Cable diameter min. 5 mm, max. 13 mm, Tightening torque 6 ± 0.9 Nm
- ④ Cable gland: Cable diameter min. 16 mm, max. 20.5 mm, Tightening torque 6 ± 0.9 Nm
- ⑤ Tightening torque: 3.5 ± 0.5 Nm
- ⑥ Mounting holes: for FlowGrid
- ⑦ Installation position: Shaft horizontal (motor support plate must stand upright!) or rotor on bottom, rotor on top on request!

Pin assignment: (see connection diagram)

RadiPac 710

EC centrifugal fans, backward curved



Material/surface

- Support bracket: Steel, painted black
- Support plate: Sheet steel, galvanized
- Spacer: aluminum
- Inlet ring: Sheet steel, galvanized
- Impeller: Sheet aluminum
- Rotor: Painted black
- Electronics housing: Die-cast aluminum

Mechanical characteristics

- Number of blades: 5
- Direction of rotation: Clockwise viewed toward rotor
- Installation position: See product drawing
- Condensation drainage holes: Rotor side
- Mode: Continuous operation (S1)
- Mounting: Maintenance-free ball bearings

Further Information



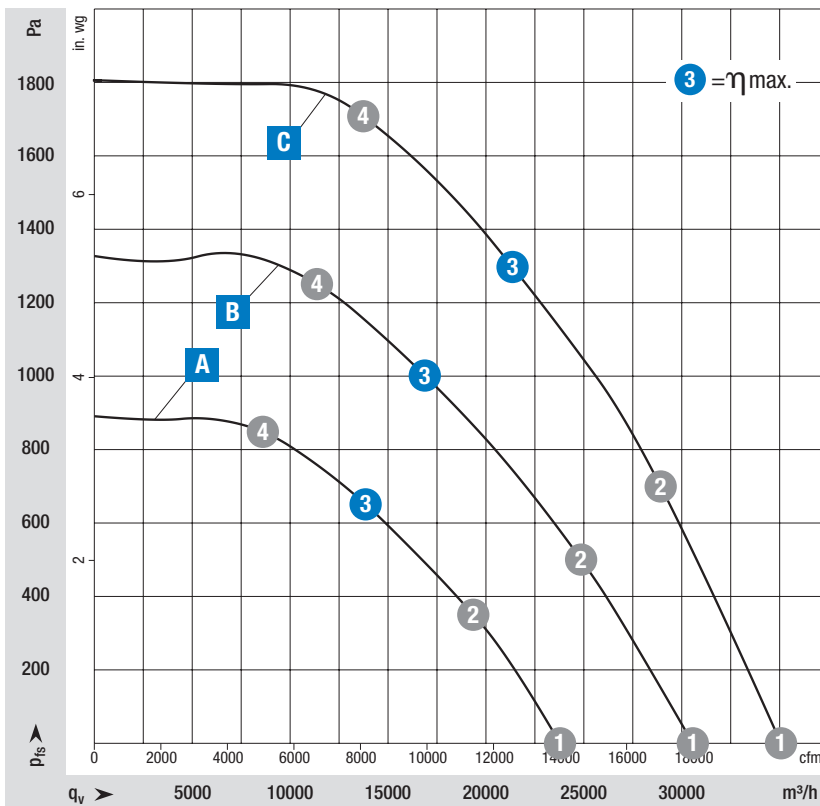

- Information about touch current, electrical connection, degree of protection, insulation class, environmental protection class, EMC standards as well as standards and approvals can be found in the product-specific data sheets.

on Page 96	Drawings
on Page 154	Accessories
on Page 166	Connection diagrams and technical features
on Page 172	Technical parameters & scope
More at	www.ebmpapst.com/worldwide www.ebmpapst.com/radipac



Measuring requirements

Air performance measured according to: ISO 5801, installation category A, with ebm-papst inlet ring without contact protection. Intake-side sound level: L_{wA} according to 13347, L_{wA} measured at 1 m distance from fan axis. The values given are only applicable under the specified measuring conditions and may differ depending on the installation conditions. In the event of deviation from the standard configuration, the parameters must be checked in installed condition.

Curve				Operating point	Nominal voltage	Speed n	Max. Input power P_{in}	Max. Input current I	Sound power level L _{WA}	Perm. ambient temp.	Degree of protection	Conn. diagram
Nominal voltage range 3-380-480 V AC, 50/60 Hz												
Type	Part number	Fan type		1	2	3	4					
A	VBS0710PTTRS	R3G710PC0503	Centrifugal fan	400	1150	1950	3,05	83	-40..+40	IP 55	RP4)	
	VBH0710PTTRS	K3G710PC0503	Support bracket	400	1150	3195	4,90	81				
				400	1150	3750	5,70	78				
				400	1150	3485	5,33	81				
B	---	---	Centrifugal fan	400	1430	3730	5,88	89	-40..+40	IP 55	RP1)	
				400	1430	5785	8,90	86				
	VBF0710PTVQS	K3G710PV0501	Cube	400	1430	7050	10,70	84				
				400	1430	6765	10,35	86				
C	---	---	Centrifugal fan	400	1680	5995	9,70	91	-40..+40	IP 55	RP1)	
				400	1680	9630	15,00	87				
	VBF0710PTVTS	K3G710PW0601	Cube	400	1680	11450	17,70	85				
				400	1680	10745	16,65	89				

Subject to change

Values set in blue are nominal data at operating point with maximum load.

RadiPac 710

A VBS0710PTTRS R3G710PC0503 (EC centrifugal fan)

Dimensions in mm

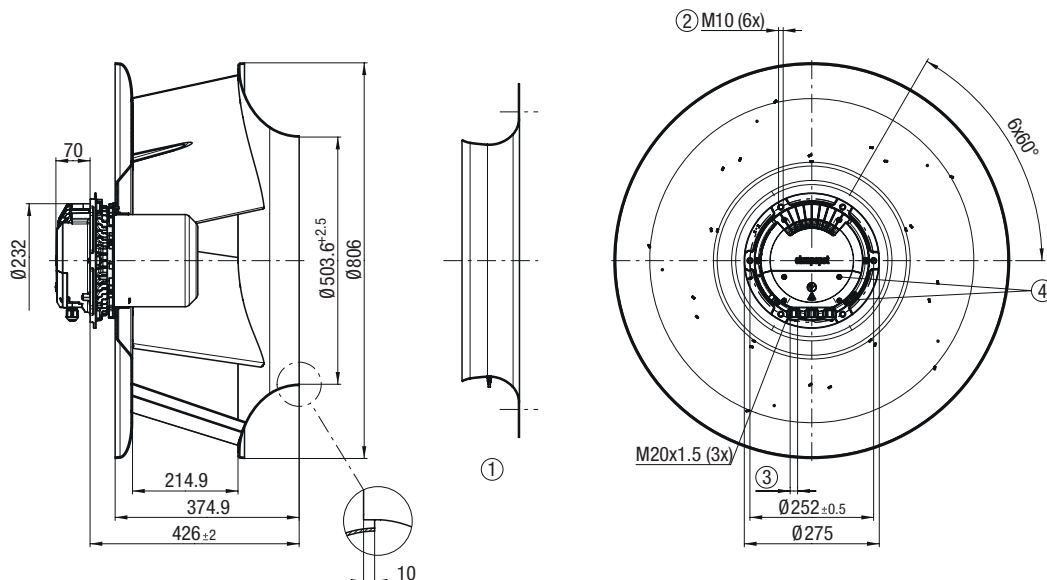

- ① **Accessory part:** Inlet ring 71075-2-4013 with pressure tap (k-factor: 545) not included in scope of delivery (Dimensions: see "Accessories" chapter)
- ② **Max. clearance of screw:** 20 mm
- ③ **Cable diameter:** min. 4 mm, max. 10 mm, Tightening torque 2±0,3 Nm
- ④ **Tightening torque:** 1,5±0,2 Nm

Pin assignment: (see connection diagram)
Installation position: Shaft horizontal or rotor on bottom, rotor on top on request

A VBH0710PTTRS K3G710PC0503 (EC centrifugal module with support bracket)

Dimensions in mm

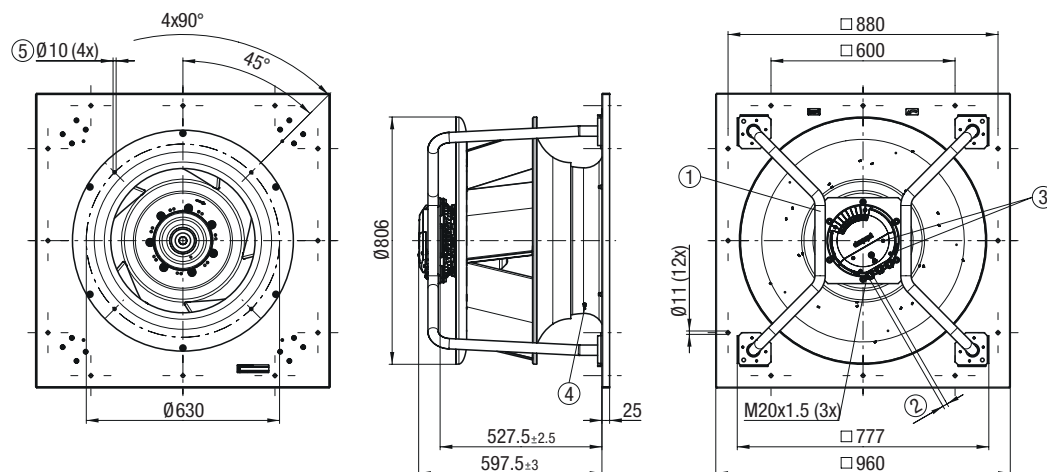

- ① **Installation position:** Shaft horizontal (Install support struts only vertically according to view!) or rotor on bottom, rotor on top on request
- ② **Cable diameter:** min. 4 mm, max. 10 mm, Tightening torque 2±0,3 Nm
- ③ **Tightening torque:** 1,5±0,2 Nm
- ④ **Inlet ring:** with pressure tap (k-factor: 545)
- ⑤ **Mounting holes:** for FlowGrid

Pin assignment: (see connection diagram)

RadiPac 710

B VBF0710PTVQS K3G710PV0501 (EC centrifugal module with cube design)

Dimensions in mm

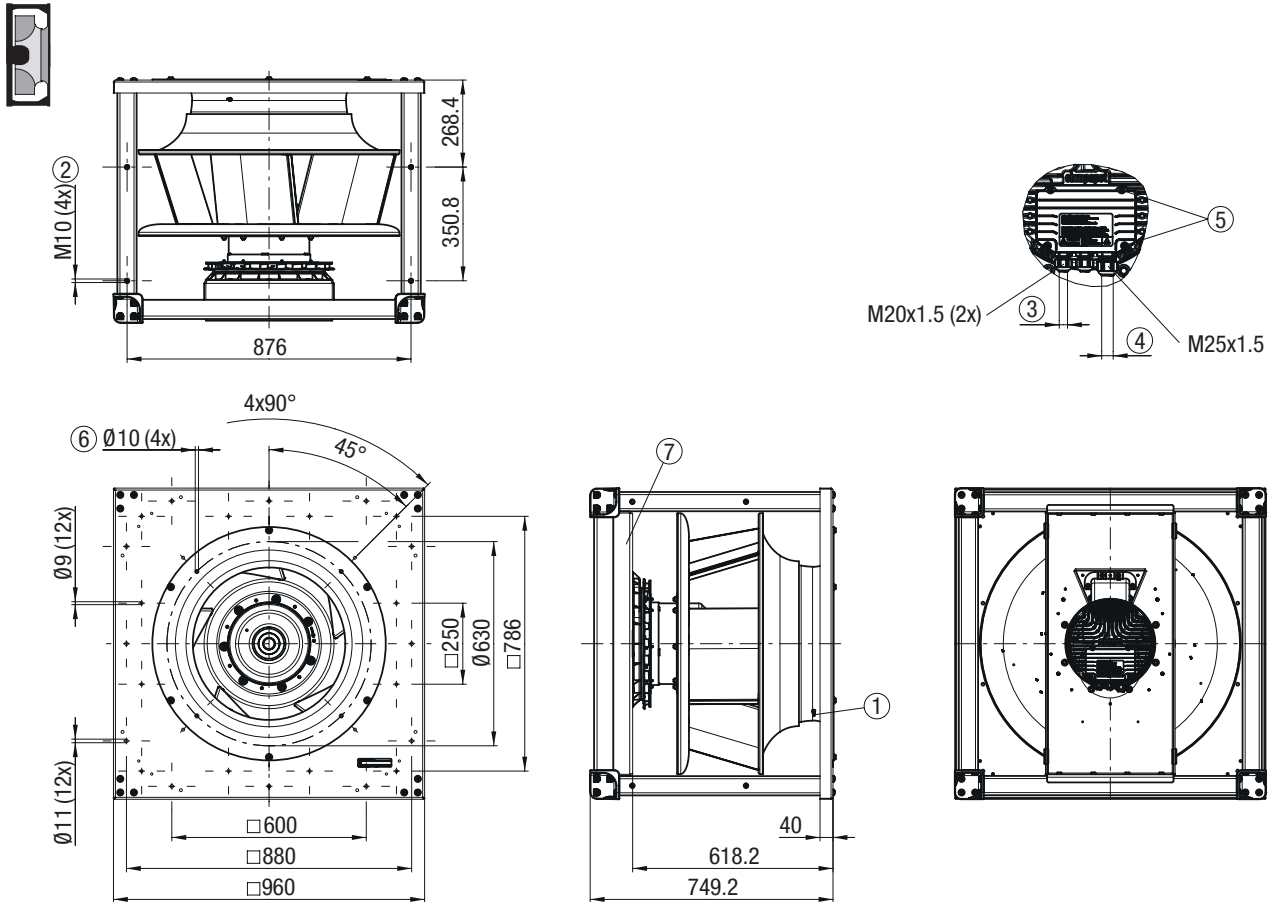

- ① Inlet ring: with pressure tap (k-factor: 545)
- ② Mounting position for vibration-absorbing elements: Tightening torque 40 Nm
- ③ Cable gland: Cable diameter min. 5 mm, max. 13 mm, Tightening torque 4 ± 0.6 Nm
- ④ Cable gland: Cable diameter min. 16 mm, max. 20.5 mm, Tightening torque 6 ± 0.9 Nm
- ⑤ Tightening torque: 3.5 ± 0.5 Nm
- ⑥ Mounting holes: for FlowGrid
- ⑦ Installation position: Shaft horizontal (motor support plate must stand upright!) or rotor on bottom, rotor on top on request!

Pin assignment: (see connection diagram)

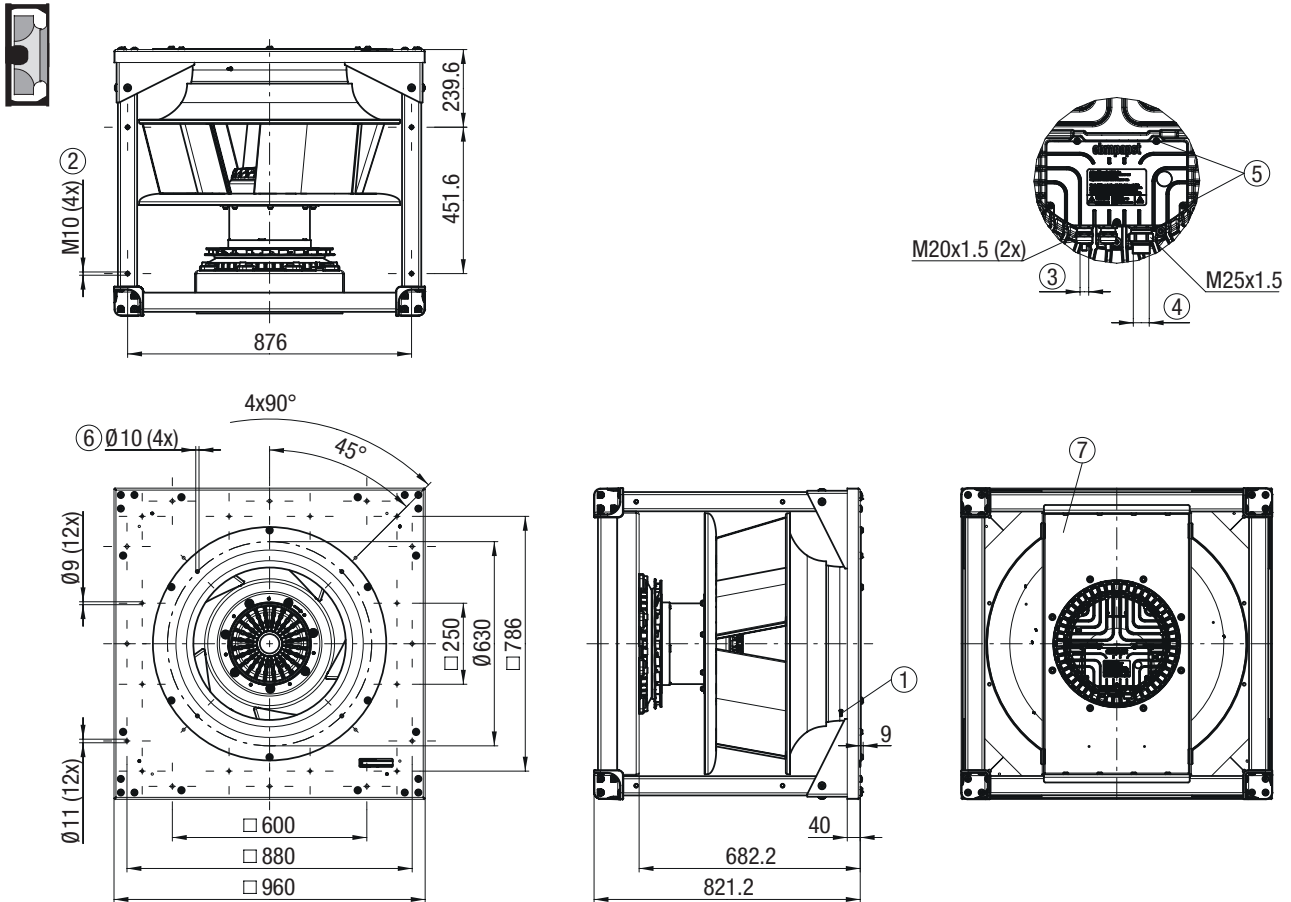

- ① Inlet ring: with pressure tap (k-factor: 545)
- ② Mounting position for vibration-absorbing elements: Tightening torque 40 Nm
- ③ Cable gland: Cable diameter min. 5 mm, max. 13 mm, Tightening torque 6 ± 0.9 Nm
- ④ Cable gland: Cable diameter min. 16 mm, max. 20.5 mm, Tightening torque 6 ± 0.9 Nm
- ⑤ Tightening torque: 3.5 ± 0.5 Nm
- ⑥ Mounting holes: for FlowGrid
- ⑦ Installation position: Shaft horizontal (motor support plate must stand upright!) or rotor on bottom, rotor on top on request!

Pin assignment: (see connection diagram)

RadiPac 800

EC centrifugal fans, backward curved



Material/surface

- Support bracket: Steel, painted black
- Support plate: Sheet steel, galvanized
- Spacer: aluminum
- Inlet ring: Sheet steel, galvanized
- Impeller: Sheet aluminum
- Rotor: Painted black
- Electronics housing: Die-cast aluminum

Mechanical characteristics

- Number of blades: 5
- Direction of rotation: Clockwise viewed toward rotor
- Installation position: See product drawing
- Condensation drainage holes: Rotor side
- Mode: Continuous operation (S1)
- Mounting: Maintenance-free ball bearings

Further Information





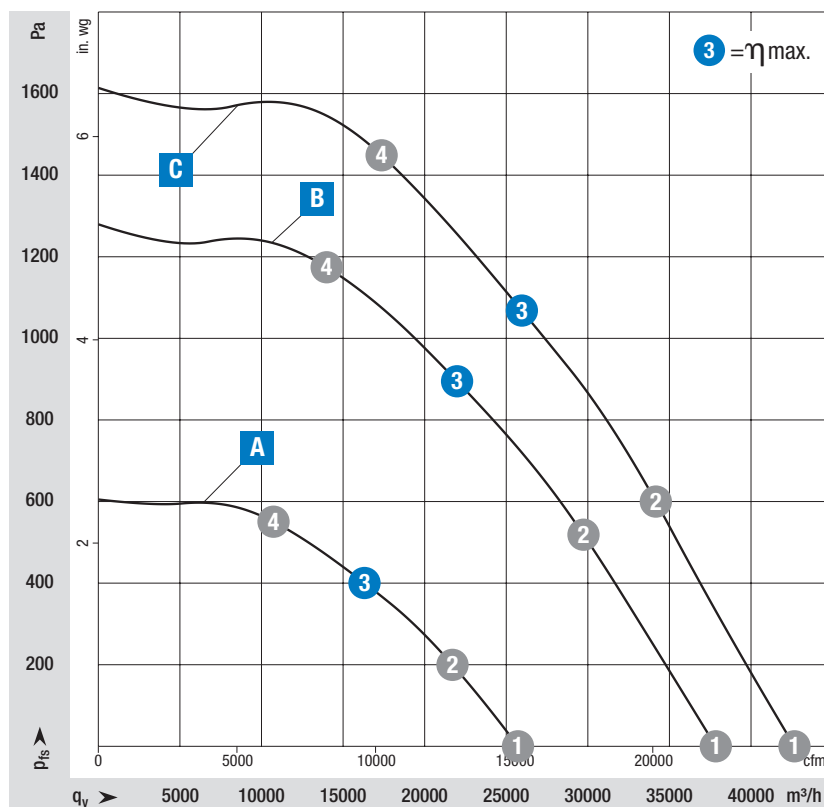







- Information about touch current, electrical connection, degree of protection, insulation class, environmental protection class, EMC standards as well as standards and approvals can be found in the product-specific data sheets.

on Page 102	Drawings
on Page 154	Accessories
on Page 166	Connection diagrams and technical features
on Page 172	Technical parameters & scope
More at	www.ebmpapst.com/worldwide www.ebmpapst.com/radipac



Measuring requirements

Air performance measured according to: ISO 5801, installation category A, with ebm-papst inlet ring without contact protection. Intake-side sound level: L_{wA} according to 13347, L_{wA} measured at 1 m distance from fan axis. The values given are only applicable under the specified measuring conditions and may differ depending on the installation conditions. In the event of deviation from the standard configuration, the parameters must be checked in installed condition.

Curve				Operating point	Nominal voltage	Speed n	Max. Input power P_{in}	Max. Input current I	Sound power level LWA	Perm. ambient temp.	Degree of protection	Conn. diagram
Nominal voltage range 3-380-480 V AC, 50/60 Hz												
Type	Part number	Fan type		1	2	3	4					
A	VBS0800PTTRS	R3G800PC0203	Centrifugal fan		400	845	1520	2,42	80	-40..+40	IP 55	RP4)
					400	845	2235	3,47	77			
	VBH0800PTTRS	K3G800PC0203	Support bracket		400	845	2800	4,30	74			
					400	845	2680	4,13	76			
B	---	---	Centrifugal fan		400	1215	4250	6,64	89	-25..+40	IP 55	RP1)
					400	1215	6890	10,55	85			
	VPF0800PTVTS	K3G800PV1301	Cube		400	1215	7950	12,10	83			
					400	1215	7530	11,51	86			
C	---	---	Centrifugal fan		400	1370	6370	10,26	91	-25..+40	IP 55	RP1)
					400	1370	9600	14,99	88			
	VBT0800PTVTS	K3G800PW0701	Cube		400	1370	11300	17,50	85			
					400	1370	10990	17,04	88			

Subject to change

Values set in blue are nominal data at operating point with maximum load.

RadiPac 800

A VBS0800PTTRS R3G800PC0203 (EC centrifugal fan)

Dimensions in mm

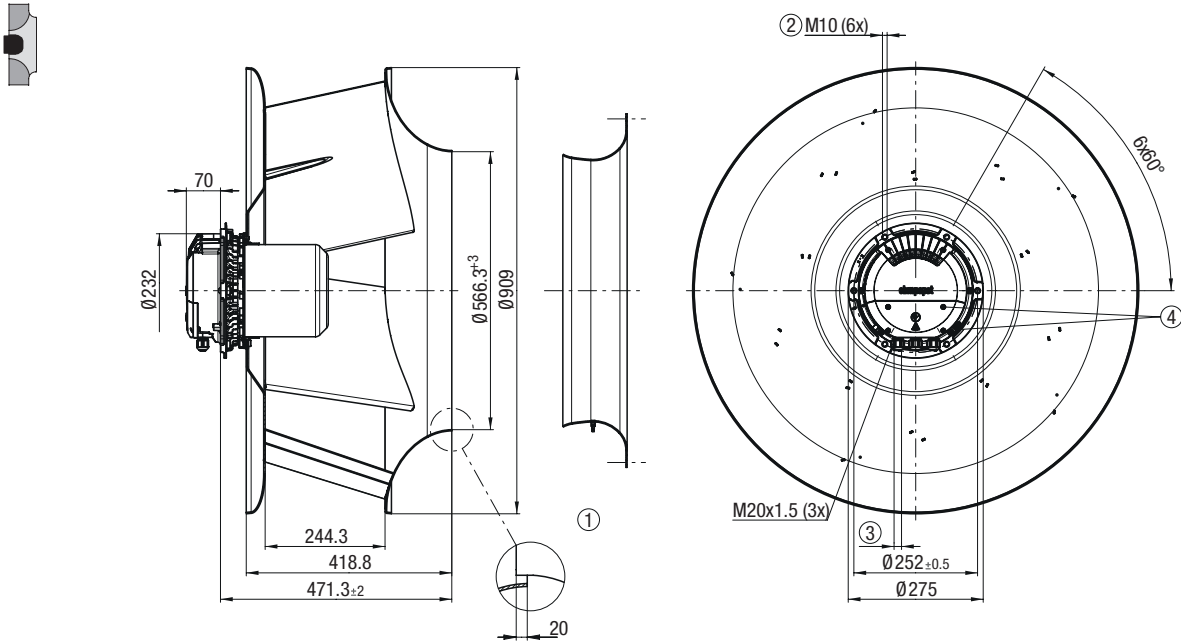

- ① Accessory part: Inlet ring 80075-2-4013 with pressure tap (k-factor: 695) not included in scope of delivery (Dimensions: see "Accessories" chapter)
- ② Max. clearance of screw: 20 mm
- ③ Cable diameter: min. 4 mm, max. 10 mm, Tightening torque 4±0,6 Nm
- ④ Tightening torque: 1,5±0,2 Nm

Pin assignment: (see connection diagram)

Installation position: Shaft horizontal or rotor on bottom, rotor on top on request

A VBH0800PTTRS K3G800PC0203 (EC centrifugal module with support bracket)

Dimensions in mm

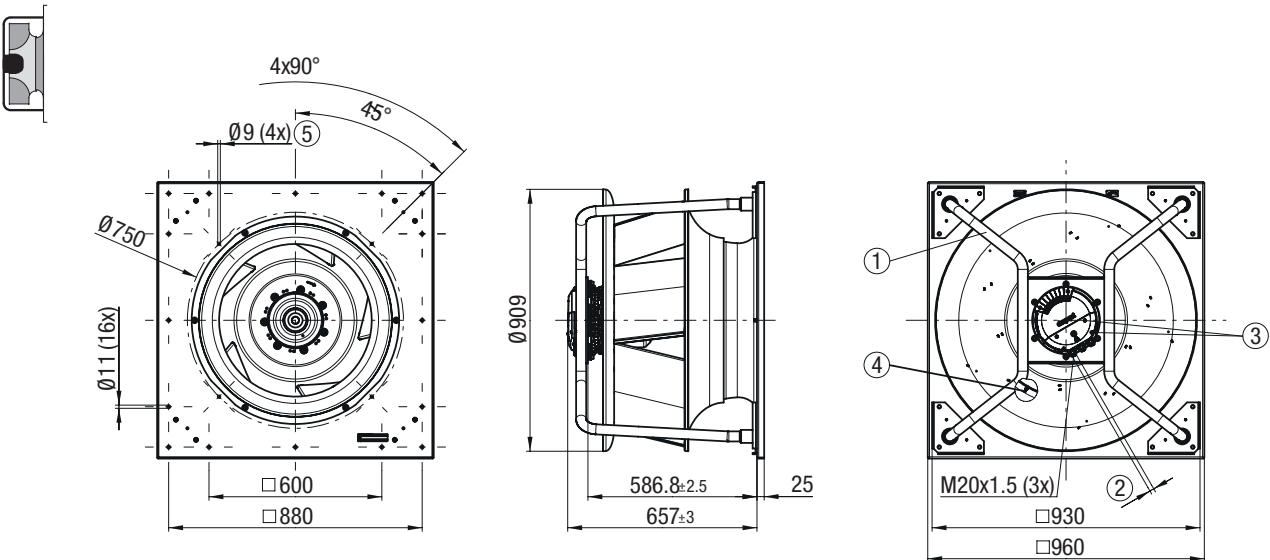

- ① Installation position: Shaft horizontal (Install support struts only vertically according to view!) or rotor on bottom, rotor on top on request
- ② Cable diameter: min. 4 mm, max. 10 mm, Tightening torque 4±0,6 Nm
- ③ Tightening torque: 1,5±0,2 Nm
- ④ Inlet ring: with pressure tap (k-factor: 695)
- ⑤ Mounting holes: for FlowGrid

Pin assignment: (see connection diagram)

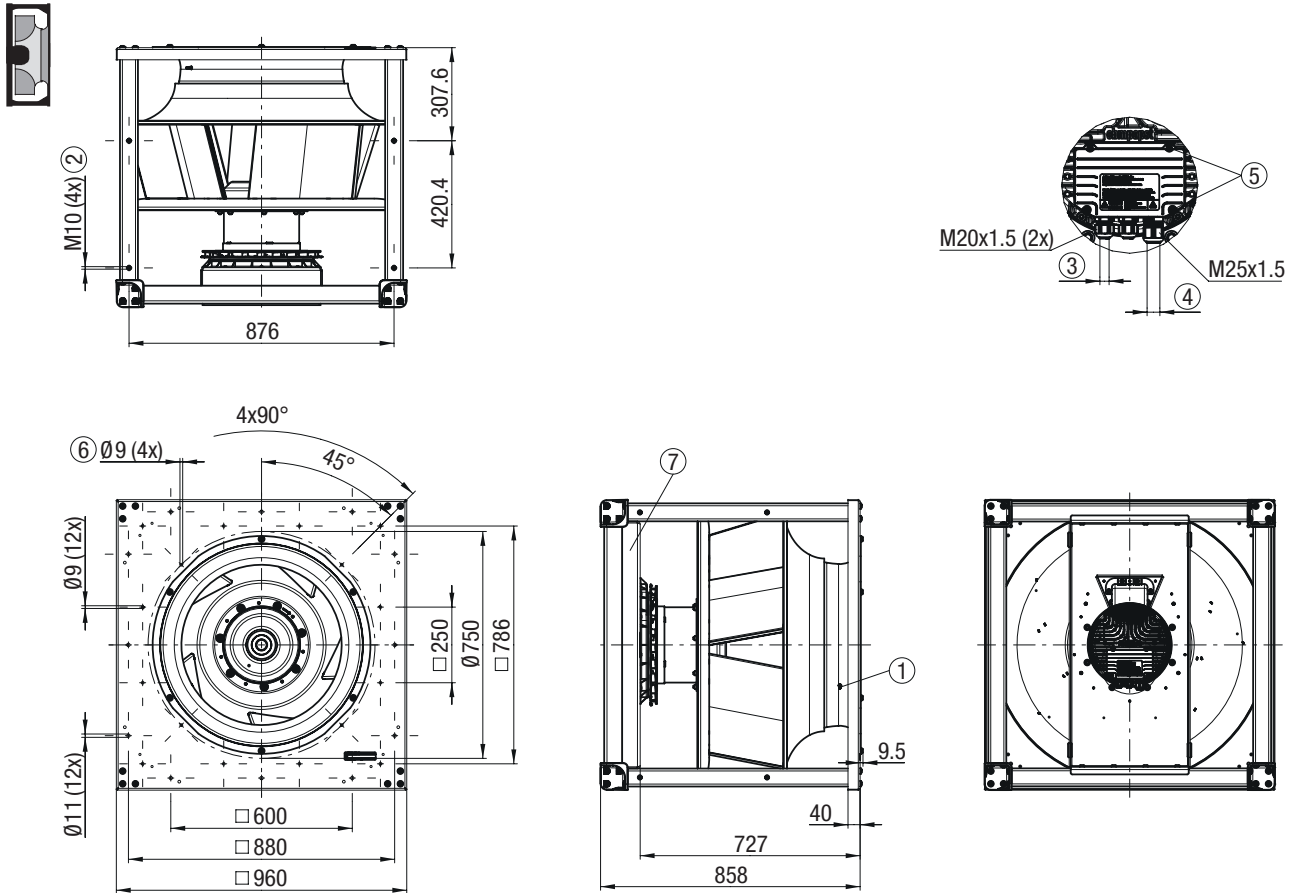

- ① Inlet ring: with pressure tap (k-factor: 695)
- ② Mounting position for vibration-absorbing elements: Tightening torque 40 Nm
- ③ Cable gland: Cable diameter min. 5 mm, max. 13 mm, Tightening torque 4 ± 0.6 Nm
- ④ Cable gland: Cable diameter min. 16 mm, max. 20.5 mm, Tightening torque 6 ± 0.9 Nm
- ⑤ Tightening torque: 3.5 ± 0.5 Nm
- ⑥ Mounting holes: for FlowGrid
- ⑦ Installation position: Shaft horizontal (motor support plate must stand upright!) or rotor on bottom, rotor on top on request!

Pin assignment: (see connection diagram)

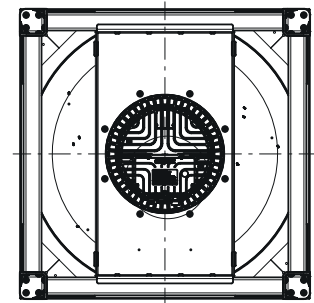
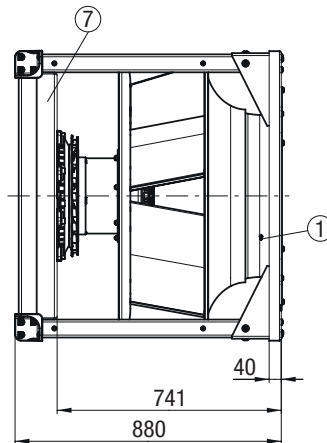
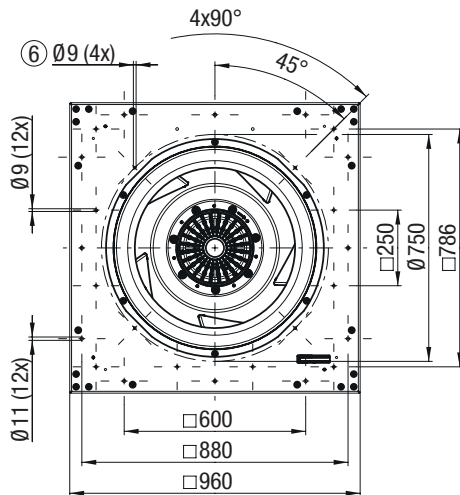
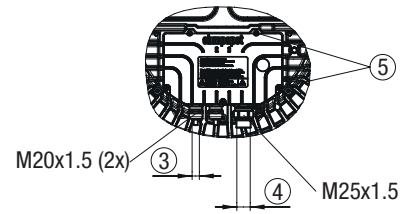
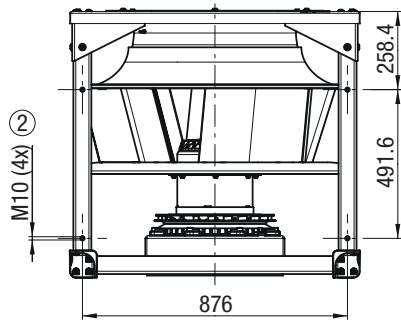

- ① Inlet ring: with pressure tap (k-factor: 695)
- ② Mounting position for vibration-absorbing elements: Tightening torque 40 Nm
- ③ Cable gland: Cable diameter min. 5 mm, max. 13 mm, Tightening torque 6 ± 0.9 Nm
- ④ Cable gland: Cable diameter min. 16 mm, max. 20.5 mm, Tightening torque 6 ± 0.9 Nm
- ⑤ Tightening torque: 3.5 ± 0.5 Nm
- ⑥ Mounting holes: for FlowGrid
- ⑦ Installation position: Shaft horizontal (motor support plate must stand upright!) or rotor on bottom, rotor on top on request!

Pin assignment: (see connection diagram)

RadiPac 1000

EC centrifugal fans, backward curved

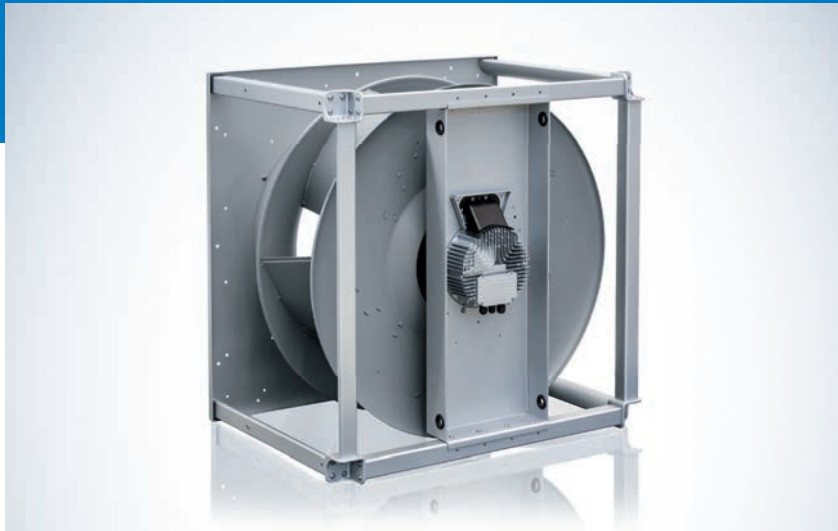

Material/surface

- Support plate: Sheet steel, galvanized
- Spacer: aluminum
- Inlet ring: Sheet steel, galvanized
- Impeller: Sheet aluminum
- Rotor: Painted black
- Electronics housing: Die-cast aluminum

Mechanical characteristics

- Number of blades: 5
- Direction of rotation: Clockwise viewed toward rotor
- Installation position: See product drawing
- Condensation drainage holes: Rotor side
- Mode: Continuous operation (S1)
- Mounting: Maintenance-free ball bearings

Further Information

- Information about touch current, electrical connection, degree of protection, insulation class, environmental protection class, EMC standards as well as standards and approvals can be found in the product-specific data sheets.

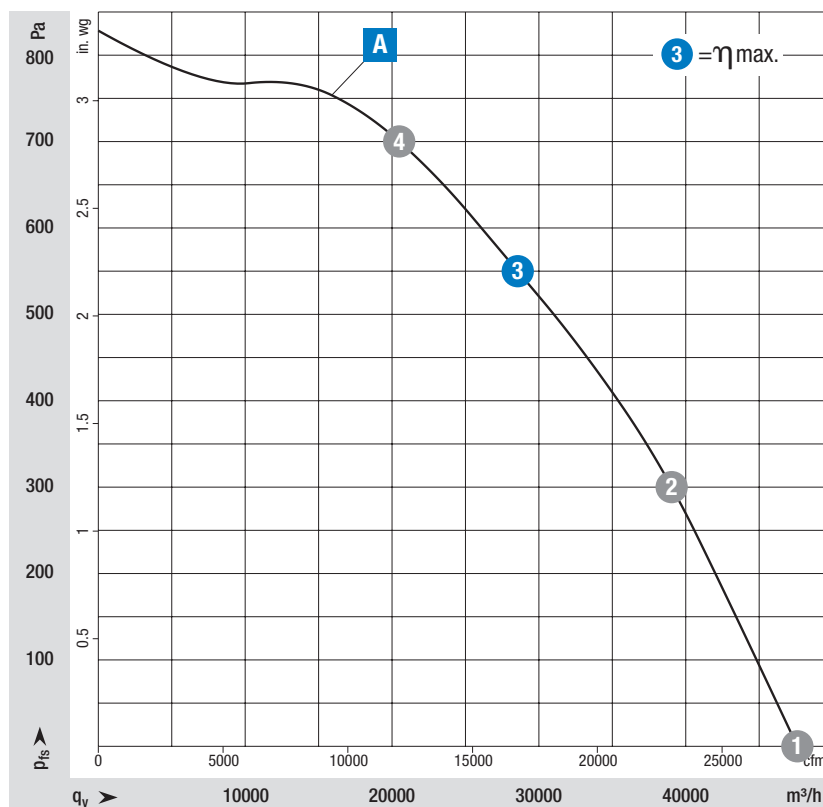

on Page 108	Drawings
on Page 154	Accessories
on Page 166	Connection diagrams and technical features
on Page 172	Technical parameters & scope
More at	www.ebmpapst.com/worldwide www.ebmpapst.com/radipac



Measuring requirements

Air performance measured according to: ISO 5801, installation category A, with ebm-papst inlet ring without contact protection. Intake-side sound level: L_{wA} according to 13347, L_{wA} measured at 1 m distance from fan axis. The values given are only applicable under the specified measuring conditions and may differ depending on the installation conditions. In the event of deviation from the standard configuration, the parameters must be checked in installed condition.

Curve

Nominal voltage range 3-380-480 V AC, 50/60 Hz				Operating point	Nominal voltage	Speed n	Max. Input power P_{ed}	Max. Input current I	Sound power level LWA	Perm. ambient temp.	Degree of protection	Conn. diagram
Type	Part number	Fan type		VAC	rpm	W	A	dB(A)	°C			
---	---	Centrifugal fan		① 400	750	3540	5,63	84				
A	VBF1000PTVTS	K3GA00PV0301	Cube		② 400	750	5485	8,49	80			
					③ 400	750	6340	9,80	77	-25..+40	IP 55	RP1)
					④ 400	750	6122	9,40	79			

Subject to change

Values set in blue are nominal data at operating point with maximum load.

RadiPac 1000

A VBF1000PTVTS K3GA00PV0301 (EC centrifugal module with cube design)

Dimensions in mm

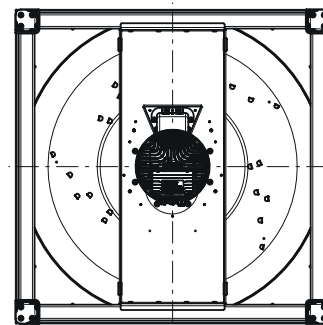
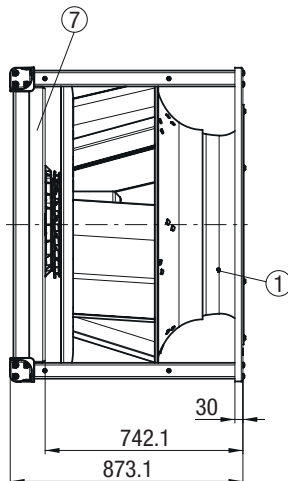
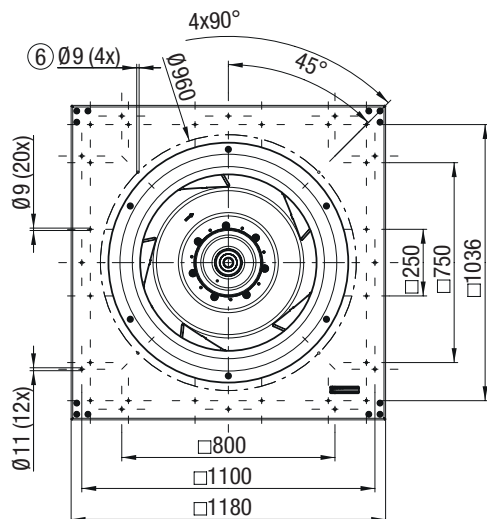
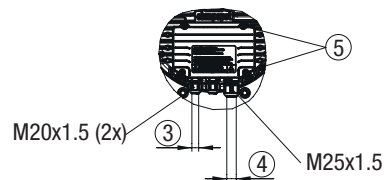
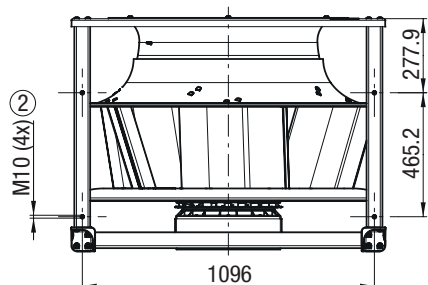

- ① Inlet ring: with pressure tap (k-factor: 1200)
- ② Mounting position for vibration-absorbing elements: Tightening torque 40 Nm
- ③ Cable gland: Cable diameter min. 5 mm, max. 13 mm, Tightening torque 4 ± 0.6 Nm
- ④ Cable gland: Cable diameter min. 16 mm, max. 20.5 mm, Tightening torque 6 ± 0.9 Nm
- ⑤ Tightening torque: 3.5 ± 0.5 Nm
- ⑥ Mounting holes: for FlowGrid
- ⑦ Installation position: Shaft horizontal (motor support plate must stand upright!) or rotor on bottom, rotor on top on request!

Pin assignment: (see connection diagram)

Standard-compliant ventilation with ready-to-install RadiPacs for the food service sector and process exhaust air:

There's something in the air. Operators of commercial kitchens have a thing or two to say about that; cooking fouls the surrounding air with grease vapors and combustion gases, not to mention heat and moisture. All that can quickly make the air quality reach hygienically questionable levels, not only in the kitchen but also in the serving area and throughout the dining areas – where bad smells can ruin the pleasant atmosphere. So legislation calls for the installation of air handling units (AHUs) in these areas. They extract air pollutants, moisture and odors from the air and bring in cool and clean air from outside.

Radically perfect with RadiPac.

Keeping air clean in canteens and cafeterias can be challenging. To improve air quality, fans used in AHUs have to meet special requirements. According to VDI 2052, motors may not lie directly in the path of air flows bearing particulates.

In addition, incoming air must be kept free of contaminants and, according to EN 16282, the fans need to be easily accessible and easy to clean. At the same time, the AHUs have to serve as humidity and temperature control in the rooms.

To meet this challenge, ebm-papst modified its proven RadiPac product range with EC centrifugal fans and optimized it for these special conditions. Now, manufacturers of AHUs for the food service sector and emissions-heavy processes or higher flow medium temperatures can finally benefit from the advantages of energy-efficient EC technology as these fans meet all of their requirements.



RadiPac 400 - 500

for the food service sector

ebmpapst

engineering a better life

	Page
Tender specification	112
400 - 500	114



Tender specification

EC centrifugal modules - RadiPac "Food service sector"

with motor enclosure and hose for food service sector

Fan size 400 to 500

Direct-drive single inlet centrifugal fans with backwards-curved high-performance centrifugal impellers with radial diffusers, mounted on a GreenTech EC external rotor motor with integrated control electronics and a motor enclosure.

Impeller made of aluminum, with 7 backwards-curved, continuously welded blades; flow-optimized inlet ring made of galvanized sheet steel with pressure test nipple.

Motorized impeller in accordance with DIN ISO 21940, statically and dynamically balanced on two planes to balancing grade G 6.3.

FlowGrid air-inlet grille, for reducing mounting-related and system-related noise. Ideal solution for confined intake conditions at the fan and/or if upstream turbulence-inducing fittings are unavoidable. The FlowGrid breaks up the turbulence fields and straightens the flow, resulting in distinct noise reduction.

GreenTech EC external rotor motor surpasses efficiency class IE4, permanent magnets with no rare earth elements, maintenance-free ball bearings with long-term lubrication, theoretical nominal service life of at least 40.000 hours of operation.

Soft start, integrated current limitation, extended voltage input 3~380-480 V, 50/60 Hz. The fan can be used with all standard power supply networks with unaltered air performance.

The motor and control electronics have been removed from the contaminated air flow in accordance with VDI 2052 and EN 16282. Motor and control system in accordance with EN 60335-1.

Electronics integrated in motor enclosure, low-noise commutation logic; 100% open-loop speed control; all fans have an RS485/MODBUS RTU interface and do not need to be installed with shielded cables.

Terminal box made of aluminum integrated into housing, cover made of PA66, with easily accessible connection area, environment-resistant cable glands. Robust, corrosion-resistant motor enclosure, completely sealed (IP54), made of CDP-coated sheet steel.

Support structure, ready to install, for wall mounting. Struts made of extruded aluminum profile. Mounting plate made of galvanized sheet steel. Ready-made intake nozzle for external air supply DN 100. Pre-installed, flexible air hose between motor capsule and nozzle plate; easily replaceable; good mechanical resistance, flame retardant in accordance with UL 94 V-0. Easy cleaning and inspection in accordance with EN 16282.

Any work required for isolation from structure-borne noise is to be performed by the customer. The fan satisfies the applicable EMC guidelines and requirements with regard to harmonic effects (see applicable data sheet for specific figures). Documentation and marking in accordance with the applicable EU directives.

Reliable performance data, air performance measurements in intake-side chamber test rig according to ISO 5801 and DIN 24163, sound measurements in an anechoic test chamber in accordance with DIN EN ISO 3745.

Integrated protective devices:

- Alarm relay with floating contacts (250 V AC/2 A, $\cos \varphi = 1$)
- Locked-rotor protection
- Phase failure detection
- Soft start of motors
- Line undervoltage detection
- Thermal overload protection for electronics and motor
- Short circuit protection

Optional:

- Other and specific requirements on request

Tender specification

EC centrifugal modules - RadiPac "Food service sector"

with motor enclosure and hose for food service sector

Fan size 400 to 500

Technical data:

Fan type		= K3G _____ - _____ - _____
Air flow	qV	= _____ m ³ /h, cfm
Stat. pressure increase	pfs	= _____ Pa, in wg
Stat. overall efficiency	η_{es}	= _____ %
Operating speed	n	= _____ rpm
Motor type		= EC motor
Type of control		= 0-100 % speed control
Motor efficiency class		= IE4
Total power input	Ped	= _____ kW
Specific fan power	SFP	= _____ kW/(m ³ /s)
Nominal voltage range	U _N	= _____ V
Line frequency	f	= 50 / 60 Hz
Nominal current	I _N	= _____ A
Degree of protection		= IP54
Sound power level	L _{WA} (A, in)	= _____ / L _{WA} (A, out) = _____ dB(A)
Sound pressure level (at 1 m)	L _{pA} (A, in)	= _____ / L _{pA} (A, out) = _____ dB(A)
Perm. ambient temperature	T	= _____ to _____ °C
Weight of fan	m	= _____ kg

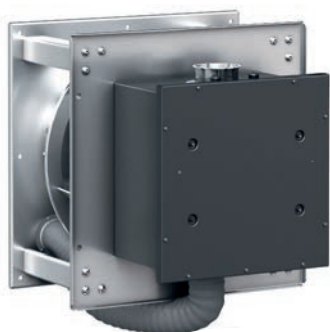

EC centrifugal fans - RadiPac
with motor enclosure and hose for food service sector
Sizes 400, 450 and 500

Refer to data sheet for dimensions and wiring.

RadiPac 400 - 500

EC centrifugal modules for the food service sector



Material/surface

- Housing: Steel, painted black
- Support plate: Sheet steel, galvanized
- Spacer: aluminum
- Inlet ring: Sheet steel, galvanized
- Impeller: Sheet aluminum

Mechanical characteristics

- Number of blades: 7
- Direction of rotation: counterclockwise seen the shaft
- Installation position: See product drawing
- Mode: Continuous operation (S1)
- Mounting: Maintenance-free ball bearings

Further Information

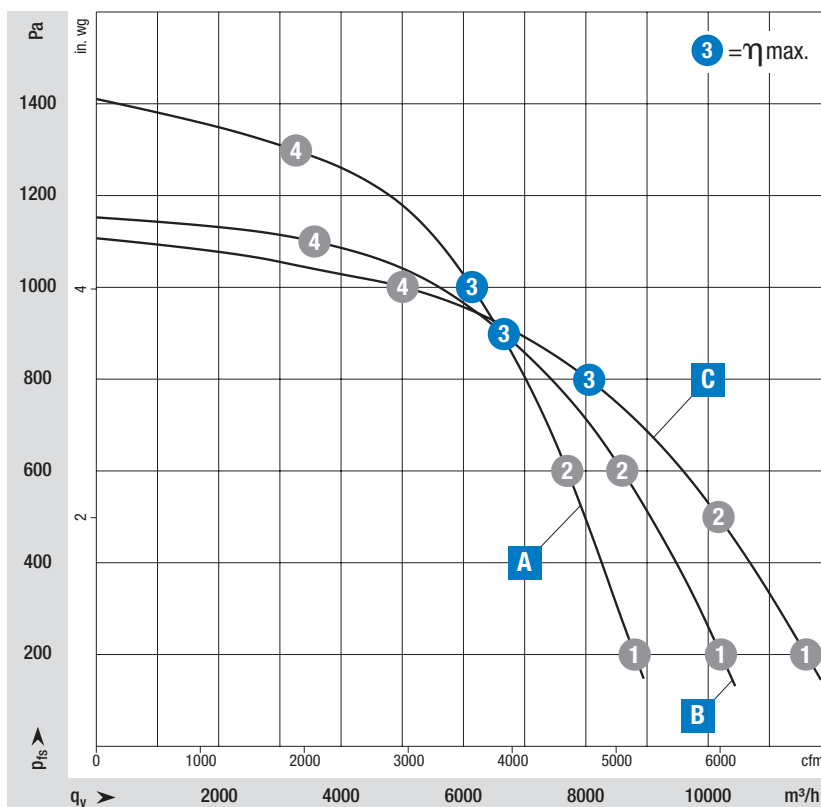

- Information about touch current, electrical connection, degree of protection, insulation class, environmental protection class, EMC standards as well as standards and approvals can be found in the product-specific data sheets.

on Page 116	Drawings
on Page 154	Accessories
on Page 166	Connection diagrams and technical features
on Page 172	Technical parameters & scope
More at	www.ebmpapst.com/worldwide www.ebmpapst.com/radipac



Measuring requirements

Air performance measured according to: ISO 5801, Installationskategorie A. Please contact ebm-papst for the exact measurement setup. Intake-side sound level: L_{pA} according to 13347, L_{pA} measured at 1 m distance from fan axis. The values given are only applicable under the specified measuring conditions and may differ depending on the installation conditions. In the event of deviation from the standard configuration, the parameters must be checked in installed condition.

Curve				Operating point	Nominal voltage	Speed n	Max. Input power P_{ed}	Max. Input current I	Sound power level L _{WA}	Min. Gegendruck	Perm. ambient temp.	Degree of protection	Conn. diagram
Nominal voltage range 3-380-480 V AC, 50/60 Hz				VAC	rpm	W	A	dB(A)	Pa	°C			
Type	Part number	Fan type											
A	VBH0400NTTLS	K3G400AQ27K1	Centrifugal module 	①	400	2550	2170	3,39	90	200	-40..+50	IP 54	RP3)
				②	400	2550	2660	4,11	89				
				③	400	2550	3000	4,60	88				
				④	400	2550	2600	4,02	89				
B	VBH0450NTTLS	K3G450AQ23K1	Centrifugal module 	①	400	2040	2010	3,16	88	200	-40..+60	IP 54	RP3)
				②	400	2040	2560	3,96	85				
				③	400	2040	2780	4,30	84				
				④	400	2040	2295	3,57	86				
C	VBH0500NTTLS	K3G500AP28K1	Centrifugal module 	①	400	1780	2160	3,37	89	200	-40..+55	IP 54	RP3)
				②	400	1780	2640	4,08	86				
				③	400	1780	3000	4,60	84				
				④	400	1780	2680	4,14	84				

Subject to change

Values set in blue are nominal data at operating point with maximum load.

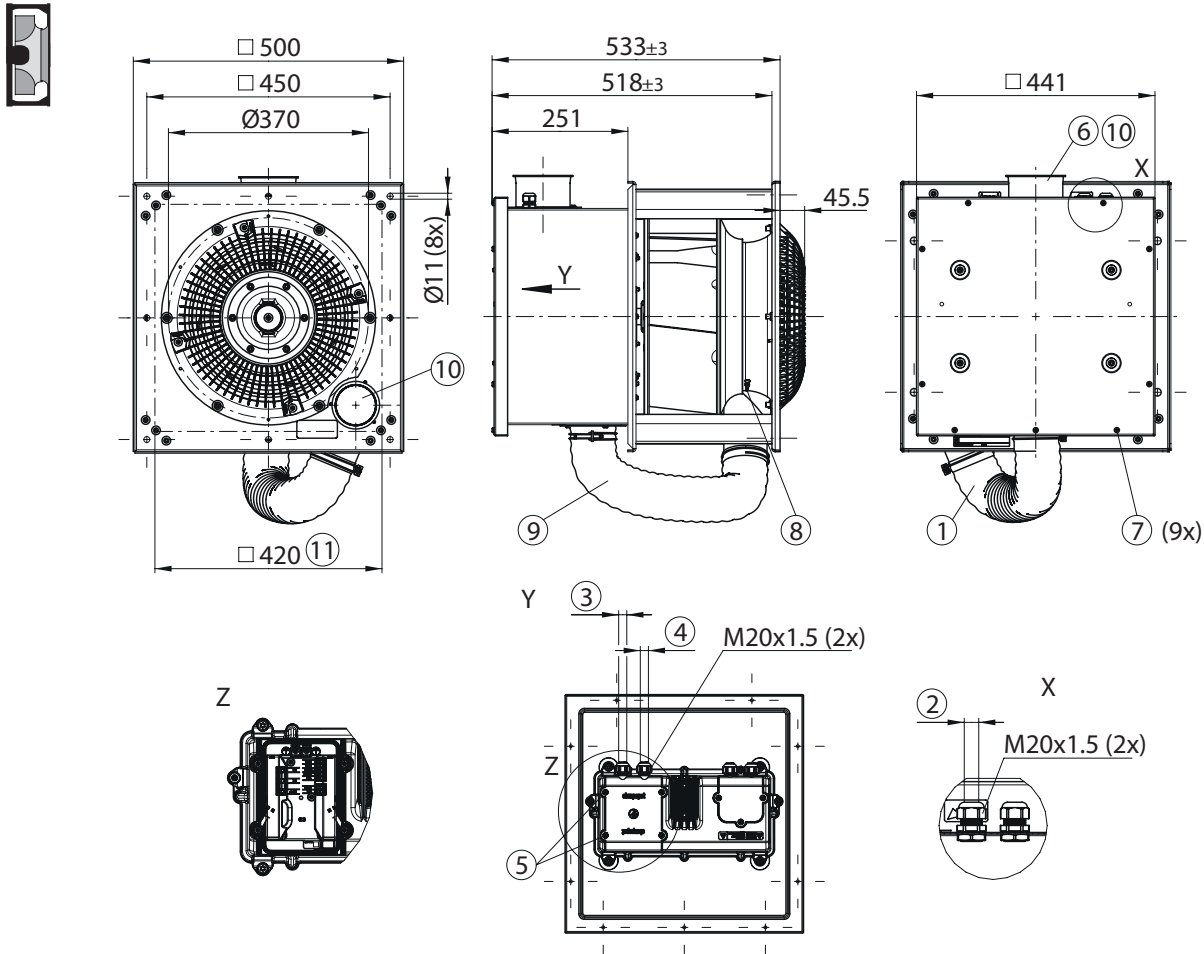

- ① **Installation position:** Shaft horizontal (only fit air hose at bottom as illustrated !) or rotor on bottom
- ② **Cable gland:** Cable diameter min. 8 mm, max. 12 mm, Tightening torque 2.5 ± 0.4 Nm
- ③ **Cable gland:** Cable diameter min. 8 mm, max. 12 mm, Tightening torque 1.8 ± 0.3 Nm
- ④ **Cable gland:** Cable diameter min. 8 mm, max. 12 mm, Tightening torque 1.8 ± 0.3 Nm
- ⑤ **Housing:** opened
- ⑥ **Terminal box:** Pin assignment see connection diagram
- ⑦ **Tightening torque:** 3 ± 0.5 Nm
- ⑧ **Customer ventilation port:** DN 100
- ⑨ **Tightening torque:** 3.5 ± 0.5 Nm
- ⑩ **Inlet ring:** with pressure tap (k-factor: 188)
- ⑪ **Spiral hose:** Ø 80 mm, PVC - coated polyester fabric (self-extinguishing)
- ⑫ **Remove caps:** prior to start-up
- ⑬ **Installation aperture**

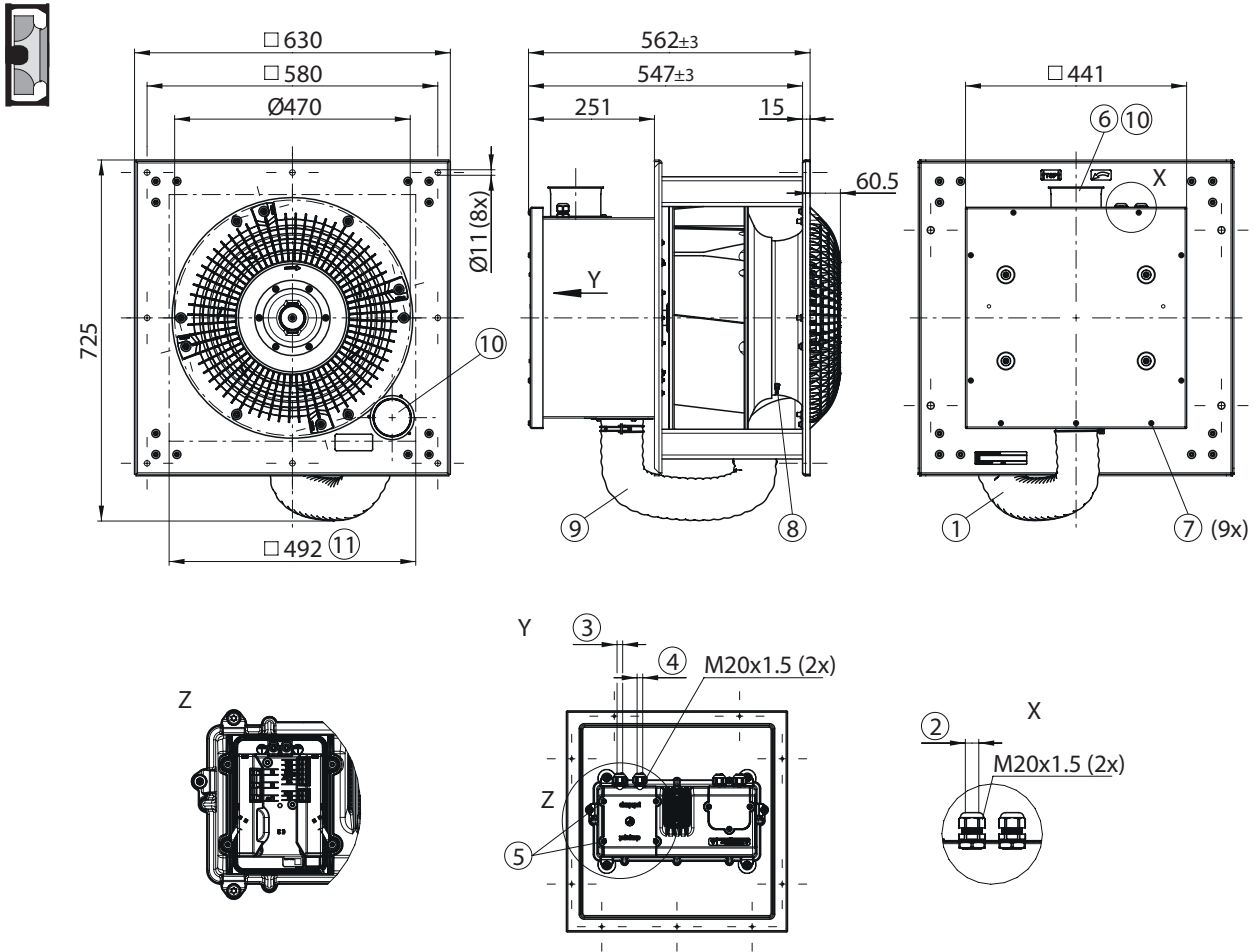

- ① **Installation position:** Shaft horizontal (only fit air hose at bottom as illustrated !) or rotor on bottom
- ② **Cable gland:** Cable diameter min. 8 mm, max. 12 mm, Tightening torque 2.5 ± 0.4 Nm
- ③ **Cable gland:** Cable diameter min. 8 mm, max. 12 mm, Tightening torque 1.8 ± 0.3 Nm
- ④ **Cable gland:** Cable diameter min. 8 mm, max. 12 mm, Tightening torque 1.8 ± 0.3 Nm
- Ⓨ **Housing:** opened
- ② **Terminal box:** Pin assignment see connection diagram
- ⑤ **Tightening torque:** 3 ± 0.5 Nm
- ⑥ **Customer ventilation port:** DN 100
- ⑦ **Tightening torque:** 3.5 ± 0.5 Nm
- ⑧ **Inlet ring:** with pressure tap (k-factor: 188)
- ⑨ **Spiral hose:** \varnothing 80 mm, PVC - coated polyester fabric (self-extinguishing)
- ⑩ **Remove caps:** prior to start-up
- ⑪ **Installation aperture**

RadiPac 500

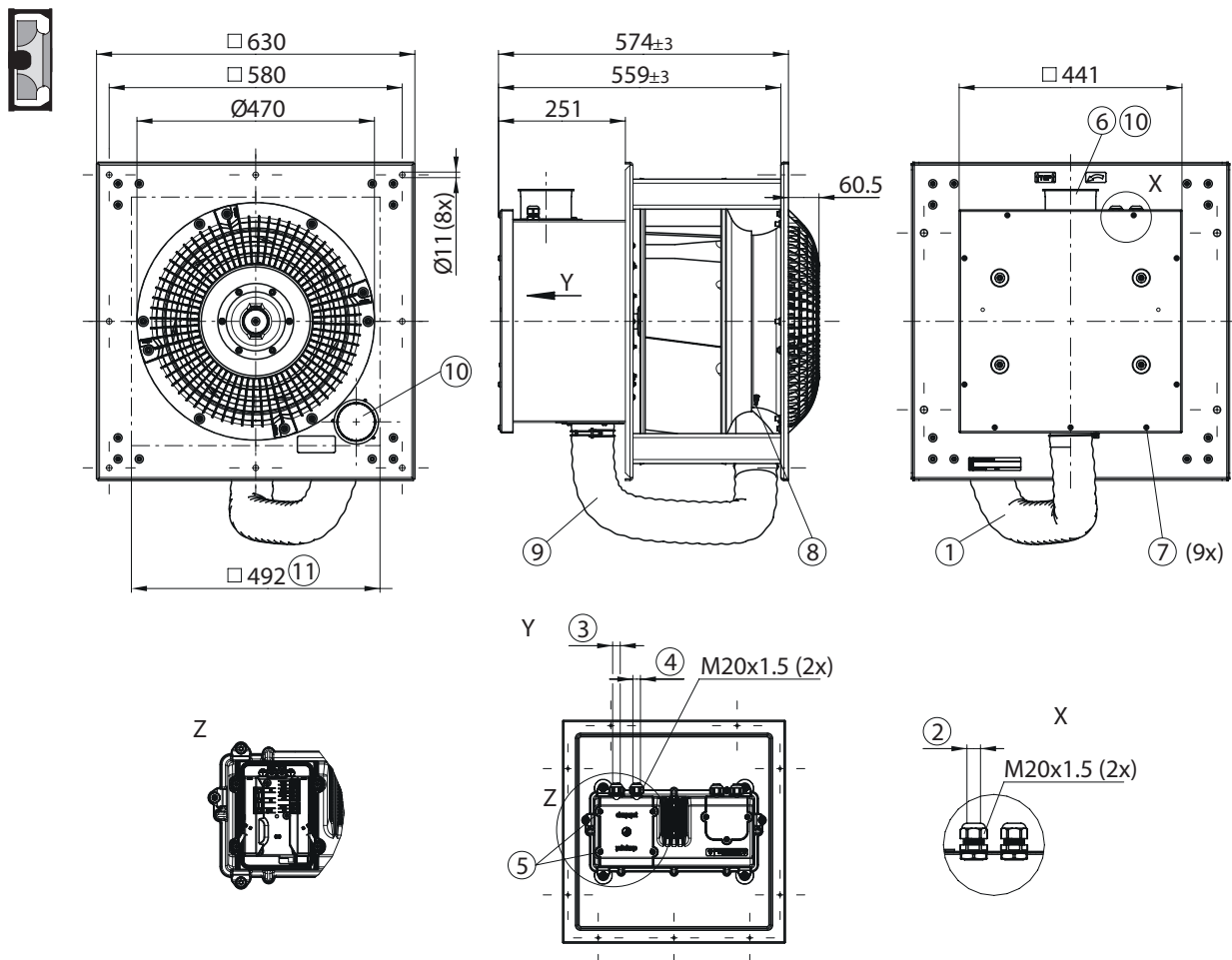

- ① **Installation position:** Shaft horizontal (only fit air hose at bottom as illustrated !) or rotor on bottom
- ② **Cable gland:** Cable diameter min. 8 mm, max. 12 mm, Tightening torque 2.5 ± 0.4 Nm
- ③ **Cable gland:** Cable diameter min. 8 mm, max. 12 mm, Tightening torque 1.8 ± 0.3 Nm
- ④ **Cable gland:** Cable diameter min. 8 mm, max. 12 mm, Tightening torque 1.8 ± 0.3 Nm
- ⑤ **Housing:** opened
- ⑥ **Terminal box:** Pin assignment see connection diagram
- ⑦ **Tightening torque:** 3 ± 0.5 Nm
- ⑧ **Customer ventilation port:** DN 100
- ⑨ **Tightening torque:** 3.5 ± 0.5 Nm
- ⑩ **Inlet ring:** with pressure tap (k-factor: 188)
- ⑪ **Spiral hose:** Ø 80 mm, PVC - coated polyester fabric (self-extinguishing)
- ⑫ **Remove caps:** prior to start-up
- ⑬ **Installation aperture**

Ventilating large buildings efficiently – with ready-to-install RadiPacs. (Air) resistance is futile:

Special challenges call for special fans. To provide a reliable solution for AHU users looking to ventilate and air-condition large buildings, ebm-papst has improved and optimized its popular RadiPac series to meet their special requirements. The result: high-performance centrifugal fans with a static pressure increase of up to 2.500 Pa and air flow of up to 15.000 m³/h and available in sizes 355, 400, 560 and 630. Of course, you also benefit from the many other advantages offered by this fan line, including high reliability, energy-efficiency and compactness. And the robust cube design is again available as an option. Just install, connect with plug & play, and turn up the pressure.

Long paths and other obstacles.

Air-handling units for large buildings like airports, skyscrapers or hotels face a special challenge: Since residential and commercial space is becoming increasingly expensive, centralized and space-saving solutions are generally preferred.

That means the air has to be moved over long distances through external pressure elements and long air ducts to reach its destination – past many corners and junctions on its way to the outlets.

Things get even more difficult when it has to overcome additional obstacles such as activated carbon filters, heat exchangers and separators (internal pressure losses), because they also affect the required pressure increase.

For all such cases, fans with particularly high static pressure increase are needed – and they should be compact, efficient and reliable.

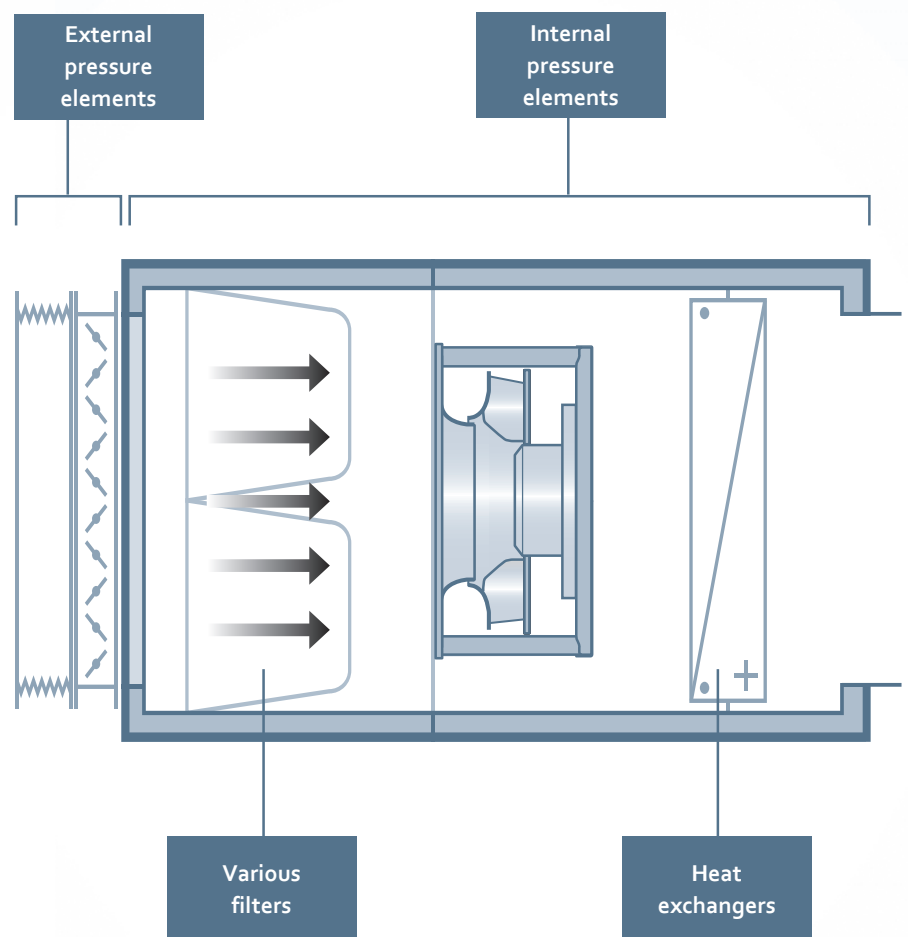

RadiPac 355 - 630

with high static pressure

ebmpapst

engineering a better life

	Page
Tender specification	122
355 - 630	124

Tender specification

EC centrifugal modules - RadiPac "High pressure"

with high static pressure

Fan size 355 to 630

Direct-drive single inlet centrifugal fans with backwards-curved high-performance centrifugal impellers with radial diffusers, mounted on a GreenTech EC external rotor motor with integrated control electronics.

Impeller made of aluminum, with 5 backwards-curved, continuously welded, blades; flow-optimized inlet ring made of galvanized sheet steel with pressure test nipple.

Motorized impeller statically and dynamically balanced on two planes to balancing grade G 6.3 (motor size 200 to balancing grade G 4.0) in accordance with DIN ISO 21940.

GreenTech EC external rotor motor surpasses efficiency class IE4, magnets with no rare earth elements, maintenance-free ball bearings with long-term lubrication, theoretical nominal service life of at least 40.000 hours of operation.

Soft start, integrated current limitation, respectively 3~380-480 V, 50/60 Hz. Fan can be used with all standard power supply networks with unaltered air performance. Integrated electronics, low-noise commutation logic; 100 % open-loop speed control; all fans have an RS485/ MODBUS RTU interface, and do not need to be installed with shielded cables.

Terminal box made of aluminum with easily accessible connection area, environment-resistant cable glands.

Version for wall mounting:

Support bracket, sizes 355 and 400 with size 150 motor as ready-to-install support bracket intended for wall mounting. Support bracket made of bent round bar steel or round tube, welded and coated in black. Mounting plate and inlet ring made of sendzimir galvanized sheet steel.

Version for floor mounting:

Cube design, sizes 560 and 630 with size 200 motor as ready-to-install cube design intended exclusively for floor mounting. Struts made of extruded aluminum sections connected to die-cast corner plates, nozzle plate and inlet ring made of sendzimir galvanized sheet steel, motor mounting plate made of coated sheet steel. This version is not suitable for wall mounting.

Any work required for isolation from structure-borne noise to be performed by the customer. Fan satisfies the applicable EMC guidelines and requirements with regard to circuit feedback (for specific information, see the respective data sheet). Documentation and marking conform to the applicable EU Directives.

Reliable performance data, air performance measurements on intake-side chamber test rig according to ISO 5801 and DIN 24163, noise measurements in anechoic rooms according to DIN EN ISO 3745.

Integrated protective devices:

- Alarm relay with zero-potential change-over contacts (250 V AC, 2 A, $\cos \varphi = 1$)
- Locked-rotor protection
- Phase failure detection
- Soft start of motors
- Mains under-voltage detection
- Thermal overload protection for electronics and motor
- Short circuit protection

Optional:

- Other and specific requirements on request
- FlowGrid air inlet grill:
FlowGrid air inlet grill tailor-made for the fan, to reduce assembly and system-related noise. Grill made of high-grade composite material in one piece, available ready for installation and also suitable for retrofitting. Ideal solution for confined intake conditions at the fan and/or if upstream turbulence-inducing fittings are unavoidable. The FlowGrid breaks up the turbulence fields and straightens the flow, resulting in distinct noise reduction.

Tender specification

EC centrifugal modules - RadiPac "High pressure"

with high static pressure

Fan size 355 to 630

Technical data:

Fan type		= K3G_____ - _____ - _____
Air flow	qV	= _____ m ³ /h, cfm
Stat. pressure increase	pfs	= _____ Pa, in wg
Stat. overall efficiency	η_{es}	= _____ %
Operating speed	n	= _____ rpm
Motor type		= EC motor
Type of control		= 0-100 % speed control
Motor efficiency class		= IE4
Total power input	Ped	= _____ kW
Specific fan power	SFP	= _____ kW/(m ³ /s)
Nominal voltage range	U _N	= _____ V
Line frequency	f	= 50 / 60 Hz
Nominal current	I _N	= _____ A
Degree of protection		= IP55
Sound power level	L _{WA} (A, in)	= _____ / L _{WA} (A, out) = _____ dB(A)
Sound pressure level (at 1 m)	L _{pA} (A, in)	= _____ / L _{pA} (A, out) = _____ dB(A)
Perm. ambient temperature	T	= _____ to _____ °C
Weight of fan	m	= _____ kg



EC centrifugal fans - RadiPac
Support bracket
Fan size 355 - 400

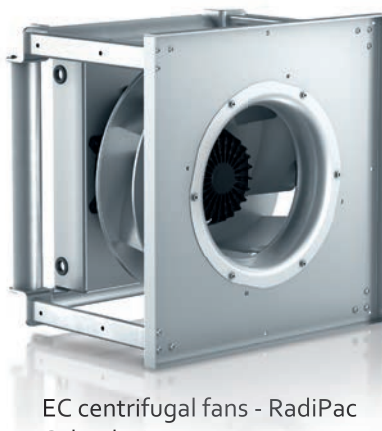

EC centrifugal fans - RadiPac
Cube design
Fan size 560 - 630



Optional
Air inlet grill Flow Grid

Refer to data sheet for dimensions and wiring.

RadiPac 355 - 630

EC centrifugal modules with high static pressure



Material/surface

- Support bracket (355,400): Steel, painted black
- Support plate (355,400): Sheet steel, galvanized
- Support structure (560,630): Sheet steel, galvanized
- Inlet ring: Sheet steel, galvanized
- Impeller: Sheet aluminum
- Rotor: Painted black
- Electronics housing: Die-cast aluminum

Mechanical characteristics

- Number of blades (355,400): 5
- Number of blades (560): 6
- Number of blades (630): 7
- Direction of rotation: Clockwise viewed toward rotor
- Installation position: See product drawing
- Condensation drainage holes: Rotor side
- Mode: Continuous operation (S1)
- Mounting: Maintenance-free ball bearings

Further Information



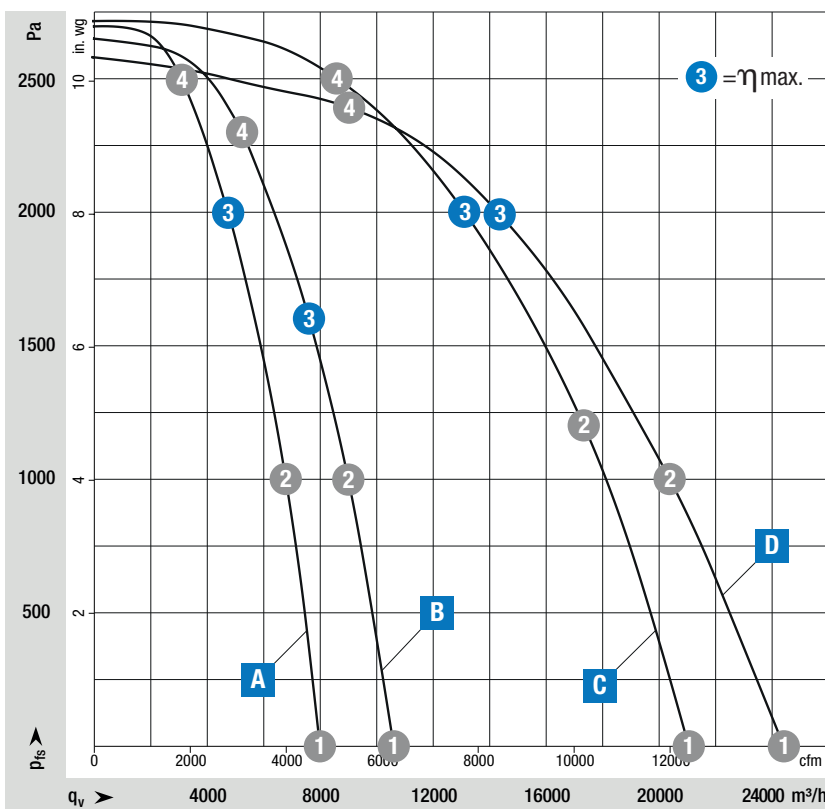

- Information about touch current, electrical connection, degree of protection, insulation class, environmental protection class, EMC standards as well as standards and approvals can be found in the product-specific data sheets.

on Page 126	Drawings
on Page 154	Accessories
on Page 166	Connection diagrams and technical features
on Page 172	Technical parameters & scope
More at	www.ebmpapst.com/worldwide www.ebmpapst.com/radipac



Measuring requirements

Air performance measured according to: ISO 5801, installation category A, with ebm-papst inlet ring without contact protection. Intake-side sound level: L_{wA} according to 13347, L_{wA} measured at 1 m distance from fan axis. The values given are only applicable under the specified measuring conditions and may differ depending on the installation conditions. In the event of deviation from the standard configuration, the parameters must be checked in installed condition.

Curve				Operating point	Nominal voltage	Speed n	Max. Input power P_{in}	Max. Input current I	Sound power level LWA	Perm. ambient temp.	Degree of protection	Conn. diagram	
Nominal voltage range 3-380-480 V AC, 50/60 Hz													VAC
Type	Part number	Fan type											
A	VBH0355NTTLS	K3G355HA3401	Support bracket		①	400	4100	2895	4,56	100	-40..+50	IP 55	RP8)
					②	400	4100	3945	6,13	95			
					③	400	4100	4700	7,20	93			
					④	400	4100	4480	6,89	99			
B	VBH400NTTPS	K3G400HB4101	Support bracket		①	400	3700	3460	5,35	102	-40..+40	IP 55	RP8)
					②	400	3700	4915	7,50	97			
					③	400	3700	6000	9,10	94			
					④	400	3700	5660	8,62	95			
C	VBF0560NTVQS	K3G560HE0701	Cube		①	400	2600	7350	11,65	105	-25..+45	IP 55	RP1)
					②	400	2600	10565	16,37	98			
					③	400	2600	12000	18,70	95			
					④	400	2600	11485	17,72	99			
D	VBF0630NTVTS	K3G630AT0911	Cube		①	400	2200	8680	13,55	107	-40..+40	IP 55	RP1)
					②	400	2200	12000	18,49	100			
					③	400	2200	13750	21,00	94			
					④	400	2200	12350	18,92	99			

Subject to change

Values set in blue are nominal data at operating point with maximum load.

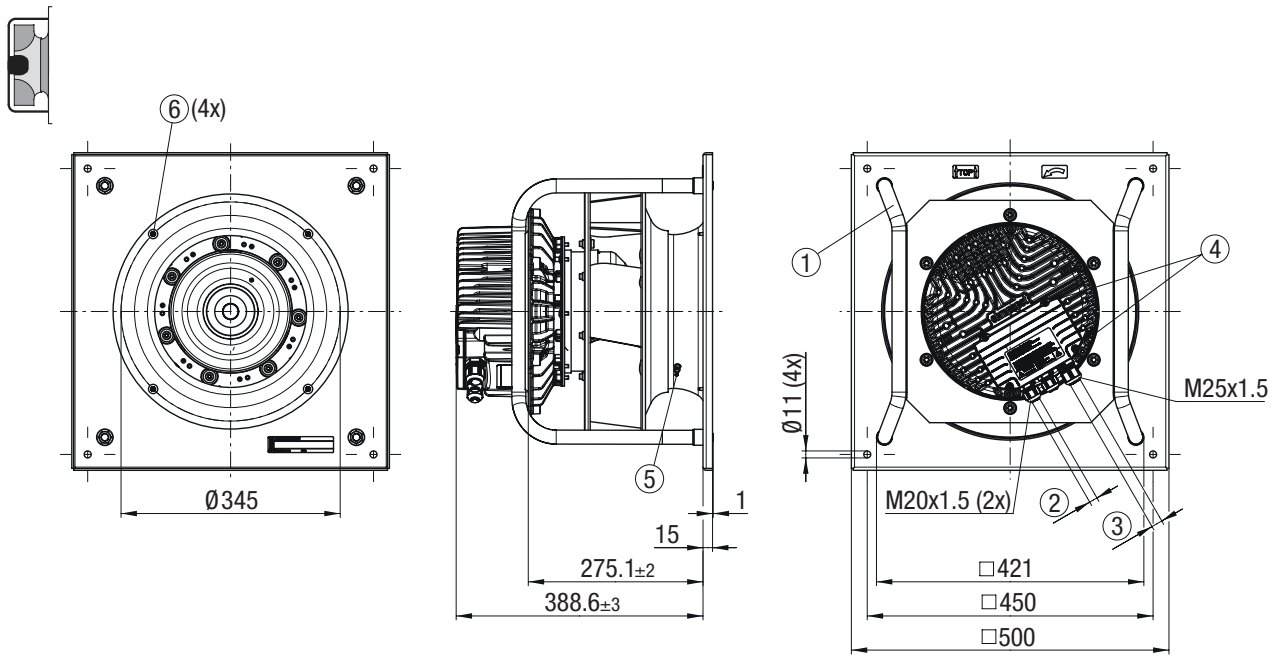

- ① **Installation position:** Shaft horizontal (Install support struts only vertically according to view!)
or rotor on bottom, rotor on top on request
- ② **Cable diameter:** min. 4 mm, max. 10 mm, Tightening torque 4±0,6 Nm
- ③ **Cable diameter:** min. 9 mm, max. 16 mm, Tightening torque 6±0,9 Nm
- ④ **Tightening torque:** 3,5±0,5 Nm
- ⑤ **Inlet ring:** with pressure tap (k-factor: 148)
- ⑥ **Mounting holes:** for FlowGrid

Pin assignment: (see connection diagram)

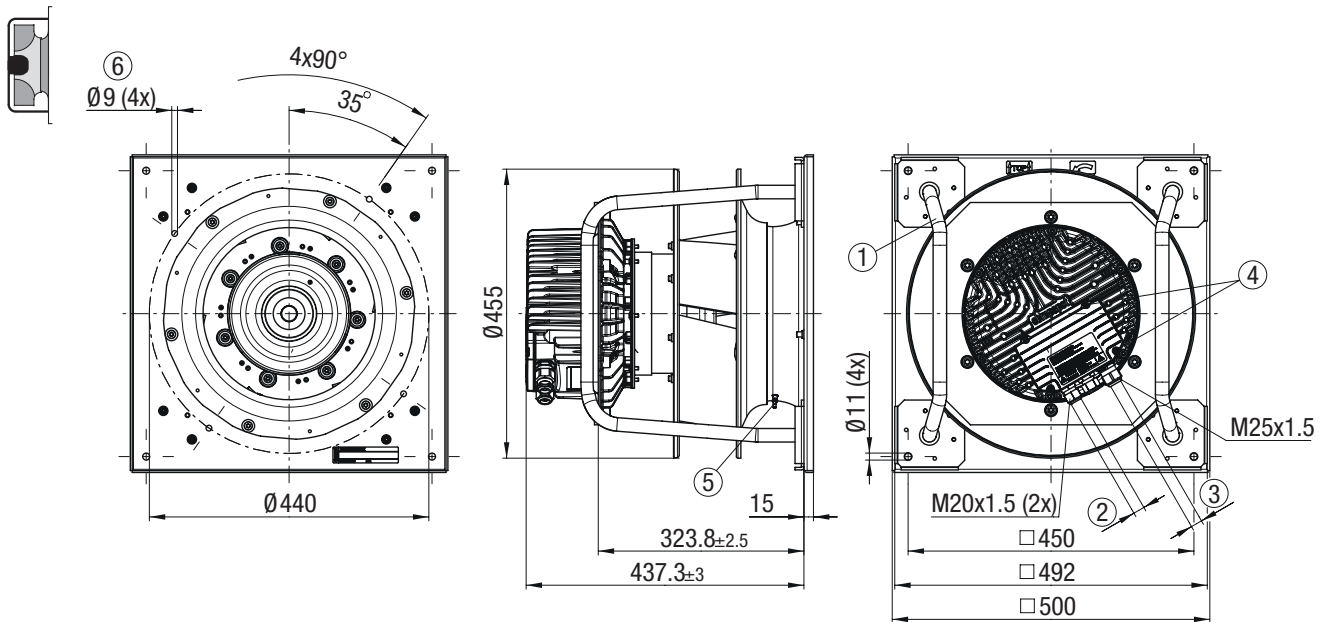

- ① **Installation position:** Shaft horizontal (Install support struts only vertically according to view!)
or rotor on bottom, rotor on top on request
- ② **Cable diameter:** min. 4 mm, max. 10 mm, Tightening torque $4 \pm 0,6$ Nm
- ③ **Cable diameter:** min. 9 mm, max. 16 mm, Tightening torque $6 \pm 0,9$ Nm
- ④ **Tightening torque:** $3,5 \pm 0,5$ Nm
- ⑤ **Inlet ring:** with pressure tap (k-factor: 188)
- ⑥ **Mounting holes:** for FlowGrid

Pin assignment: (see connection diagram)

RadiPac 560

C VBF0560NTVQS K3G560HE0701 (EC centrifugal module with cube design)

Dimensions in mm

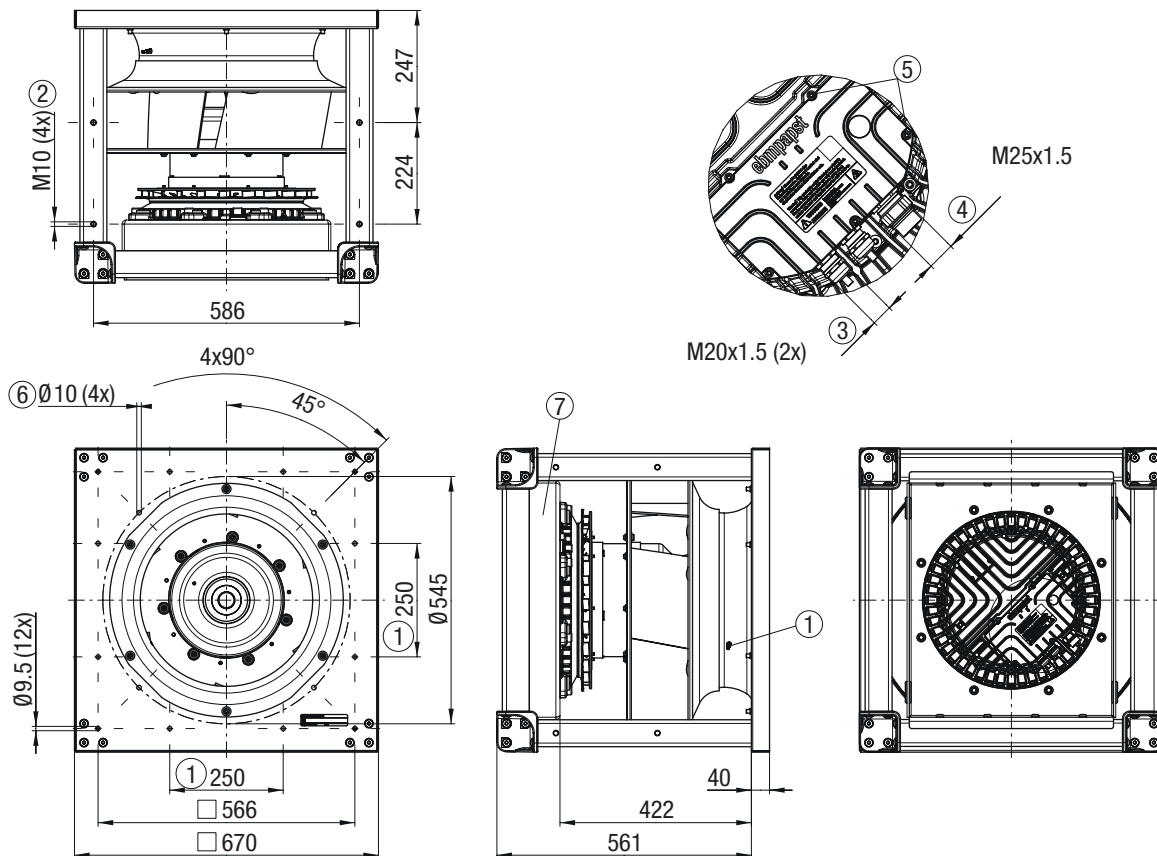

- ① Inlet ring: with pressure tap (k-factor: 348)
- ② Mounting position for vibration-absorbing elements: Tightening torque 40 Nm
- ③ Cable gland: Cable diameter min. 5 mm, max. 13 mm, Tightening torque 6 ± 0.9 Nm
- ④ Cable gland: Cable diameter min. 16 mm, max. 20.5 mm, Tightening torque 6 ± 0.9 Nm
- ⑤ Tightening torque: 3.5 ± 0.5 Nm
- ⑥ Mounting holes: for FlowGrid
- ⑦ Installation position: Shaft horizontal (motor support plate must stand upright!) or rotor on bottom, rotor on top on request!

Pin assignment: (see connection diagram)

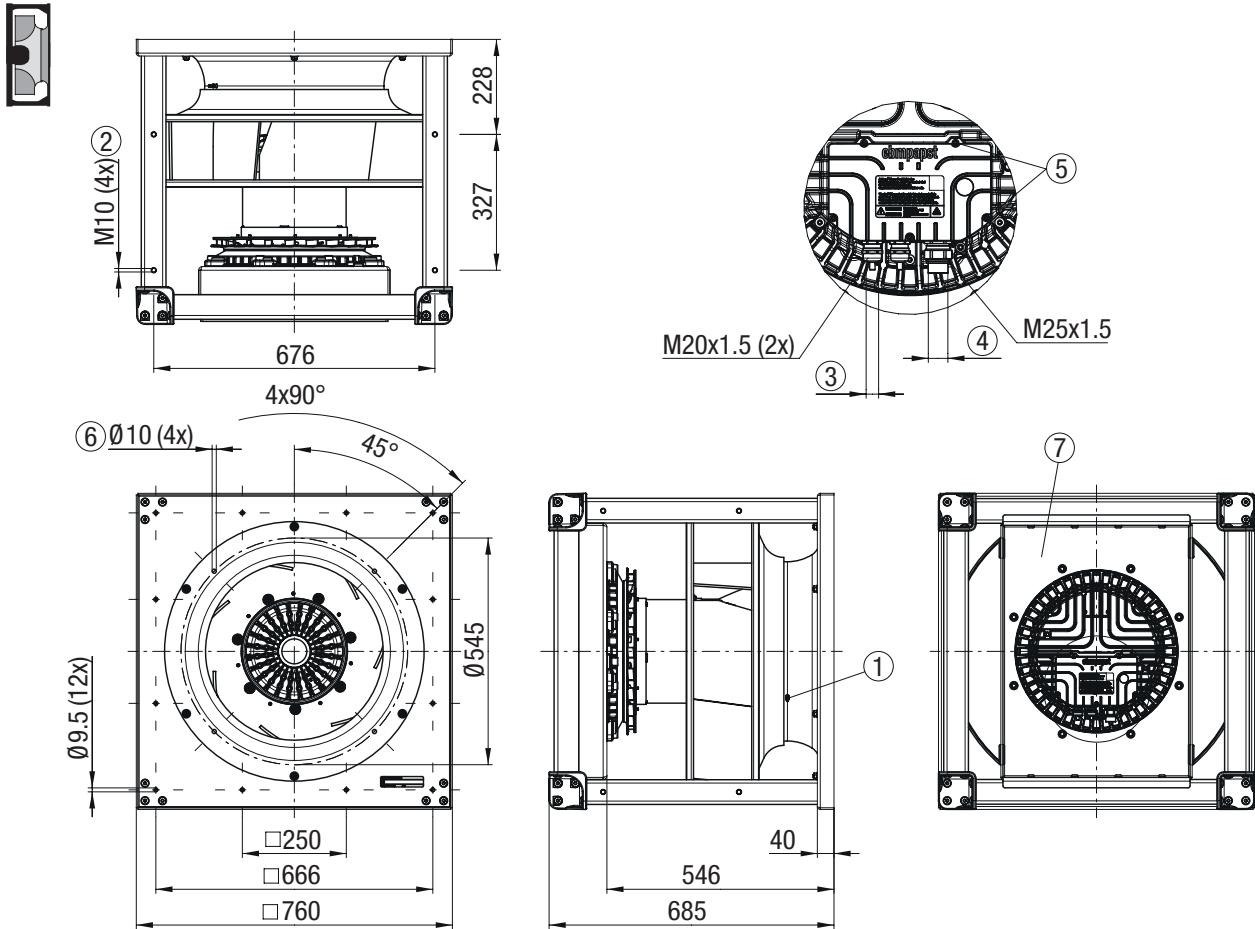

- ① Inlet ring: with pressure tap (k-factor: 438)
- ② Mounting position for vibration-absorbing elements: Tightening torque 40 Nm
- ③ Cable gland: Cable diameter min. 5 mm, max. 13 mm, Tightening torque 6 ± 0.9 Nm
- ④ Cable gland: Cable diameter min. 16 mm, max. 20.5 mm, Tightening torque 6 ± 0.9 Nm
- ⑤ Tightening torque: 3.5 ± 0.5 Nm
- ⑥ Mounting holes: for FlowGrid
- ⑦ Installation position: Shaft horizontal (motor support plate must stand upright!) or rotor on bottom, rotor on top on request!

Pin assignment: (see connection diagram)

Atmosphere Explosive

The European guideline on explosion protection

Certified safety.:

ebm-papst's ex-protected fans are based on the proven 3 kW GreenTech EC external rotor motor and are tested and certified in line with the European product directive 2014/34/EU. They therefore meet all demands made of devices used in areas at risk of explosion.

The ec centrifugal ex-protected fans are suitable for equipment group II (explosion-protected areas outside mining) and the gases and vapours substance group in explosion group IIB. The ex-protected fans can be used in hazard zones 1 and 2. They therefore correspond to category 2G (ATEX) and have the equipment protection level Gb (EN 60079-0). As per the ATEX 1999/92/EC operating directive, the facility operator is responsible for the categorisation of hazard zones. The corresponding equipment categorisation is performed by the manufacturer, i. e. ebm-papst.

ATEX fans:

RadiPac centrifugal fans for use in potentially explosive atmospheres.

These fans are available in sizes 400 to 630.

The combination of high-efficiency EC motor and integrated control electronics for use in potentially explosive atmospheres of Zones 1 and 2 is unique and simplifies the use of high-efficiency fans in such environments for the operator.



Ex marking of the ebm-papst fans as per ATEX and EN 60079-0::

Ex marking	Group	Equipment category	Pressure-resistant enclosure Protection level	Increased safety Protection level	Intrinsic safety Protection level	Explosion group	Temperature classes	Equipment protection level	Escape of gases, fog and vapours (e.g. ammonia, methane, ethane, propane, town gas, acrylonitrile, hydrogen sulphide, ethyl ether, acetaldehyde)
ebmpapst		3G Corresponding to Zone 2			ic	IIA	T1 T2	Gc Increased protection	Zone 2 Hardly ever, rarely
		II 2G Ex	db	eb	ib	IIB	T3	Gb	Zone 1 Occasionally
		Required customer specification				Required customer specification			

The following requirements are not covered:

Not available	I	1G Corresponding to Zone 0			ia	IIC	T4 T5 T6	Ga Very high protection	Zone 0 Constantly, often
----------------------	----------	--------------------------------------	--	--	-----------	------------	-------------------------------------	-----------------------------------	------------------------------------

RadiPac 400 - 630

ATEX execution

ebmpapst

engineering a better life

	Page
400 - 630	132

RadiPac 400 - 630

EC centrifugal fans, backward curved (ATEX execution)



Material/surface

- Support structure: Sheet steel, galvanized
- Inlet ring: Sheet aluminum
- Impeller: Sheet aluminum
- Rotor: Painted black
- Electronics housing: Die-cast aluminum, painted black

Mechanical characteristics

- Number of blades: 7
- Direction of rotation: Clockwise viewed toward rotor
- Installation position: See product drawing
- Condensation drainage holes: Rotor side
- Mode: Continuous operation (S1)
- Mounting: Maintenance-free ball bearings

Further Information

- Information about touch current, electrical connection, degree of protection, insulation class, environmental protection class, EMC standards as well as standards and approvals can be found in the product-specific data sheets.

on Page 134	Drawings
on Page 154	Accessories
on Page 166	Connection diagrams and technical features
on Page 172	Technical parameters & scope
More at	www.ebmpapst.com/worldwide www.ebmpapst.com/radipac

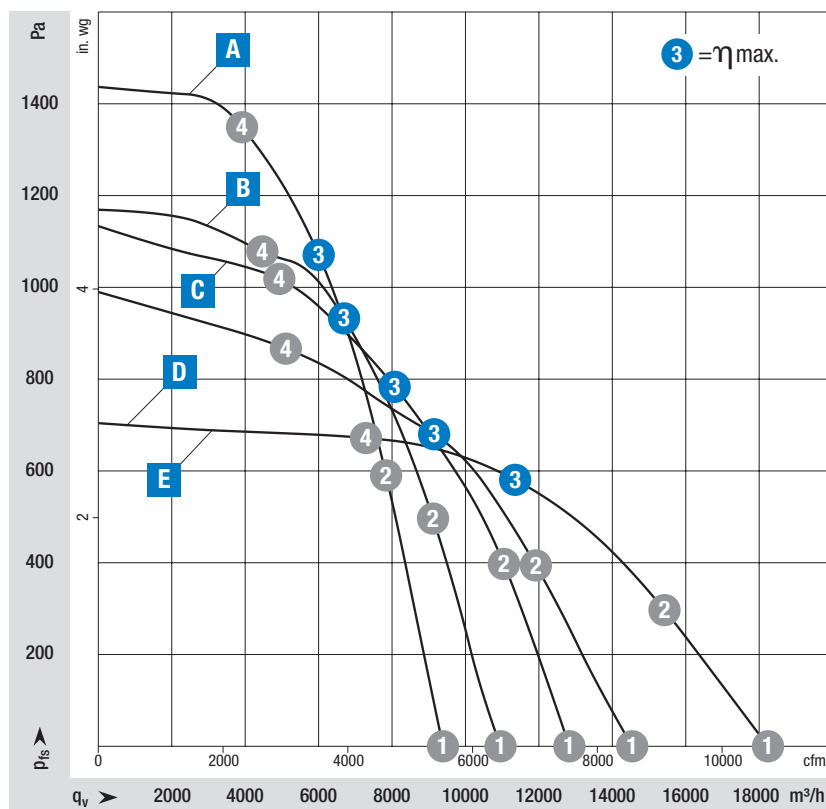

Measuring requirements

Air performance measured according to: ISO 5801, installation category A, with ebm-papst inlet ring without contact protection. Intake-side sound level: L_{pA} according to 13347, L_{pA} measured at 1 m distance from fan axis. The values given are only applicable under the specified measuring conditions and may differ depending on the installation conditions. In the event of deviation from the standard configuration, the parameters must be checked in installed condition.

Curve				Operating point	Nominal voltage	Speed n	Max. Input power P _{in}	Max. Input current I	Sound power level L _{WA}	Perm. ambient temp.	Degree of protection	Conn. diagram
Nominal voltage range 3-380-480 V AC, 50/60 Hz				VAC	rpm	W	A	dB(A)	°C			
Type	Part number	Fan type										
A	---	---	Centrifugal fan	①	400	2550	2035	3,11	92	-40..+50	IP 44	RP5)
				②	400	2550	2715	4,14	88			
				③	400	2550	3100	4,70	86			
				④	400	2550	2900	4,40	88			
	VBF0400NTTLS	K3G400AQ2390	Cube									
B	---	---	Centrifugal fan	①	400	2040	1840	2,82	92	-40..+50	IP 44	RP5)
				②	400	2040	2685	3,92	88			
				③	400	2040	2950	4,50	86			
				④	400	2040	2605	3,93	87			
	VBF0450NTTLS	K3G450AQ2490	Cube									
C	---	---	Centrifugal fan	①	400	1780	2010	3,03	94	-40..+50	IP 44	RP5)
				②	400	1780	2640	3,95	87			
				③	400	1780	2970	4,50	83			
				④	400	1780	2750	3,91	85			
	VBF0500NTTLS	K3G500AP2590	Cube									
D	---	---	Centrifugal fan	①	400	1500	1905	2,96	93	-40..+50	IP 44	RP5)
				②	400	1500	2570	3,95	89			
				③	400	1500	2940	4,50	86			
				④	400	1500	2545	3,91	86			
	VBF0560NTTTPS	K3G560AP2390	Cube									
E	---	---	Centrifugal fan	①	400	1130	1895	2,93	90	-40..+50	IP 44	RP5)
				②	400	1130	2515	3,87	84			
				③	400	1130	2970	4,60	83			
				④	400	1130	2545	3,93	82			
	VBF0630NTTRS	K3G630AP0190	Cube									

Subject to change

Values set in blue are nominal data at operating point with maximum load.

RadiPac 400 (ATEX)

A VBF0400NTTLS K3G400AQ2390 (EC centrifugal module with cube design)

Dimensions in mm

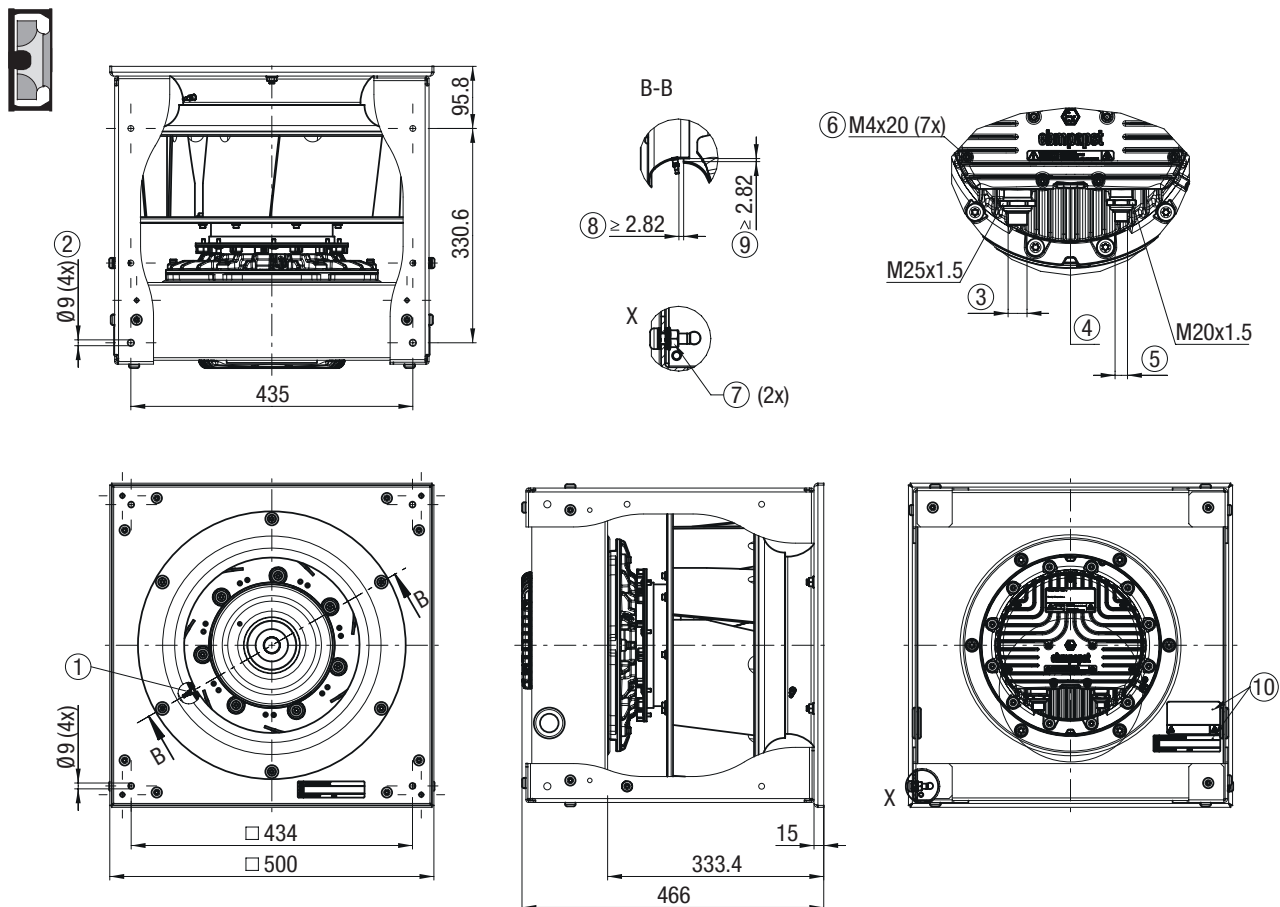

- ① Inlet ring with pressure tap
- ② Mounting position for vibration-absorbing elements
- ③ Cable gland: Cable diameter min. 10 mm, max. 16 mm, Tightening torque 6 ± 0.6 Nm, standard value depending on cable
- ④ Screw plug: M20x1.5
- ⑤ Cable gland: Cable diameter min. 10 mm, max. 14 mm, Tightening torque 6 ± 0.6 Nm standard value depending on cable
- ⑥ Terminal box fastening screws: Tightening torque: 3.5 ± 0.5 Nm
- ⑦ Ground connection point: M8 (Functional ground for electrostatic discharge, no protective earth), do not unfasten the nut provided, contact is established by way of another nut
- ⑧ Axial gap dimension
- ⑨ Radial gap dimension
- ⑩ Additional nameplate and warning sticker: in Russian

Pin assignment: (see connection diagram)

Installation position: Shaft horizontal (base mounting only) or rotor on bottom, rotor on top not permitted !

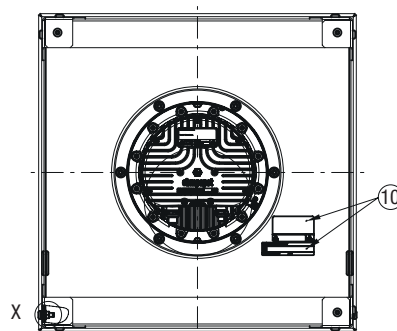
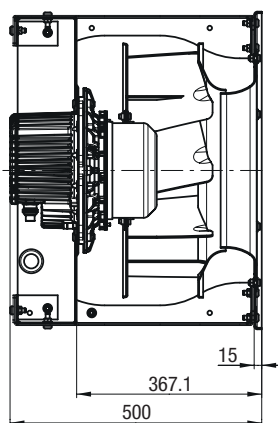
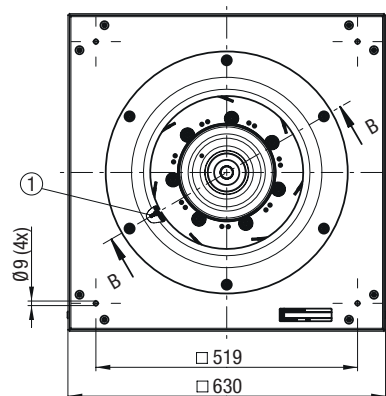
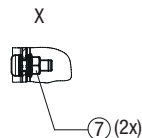
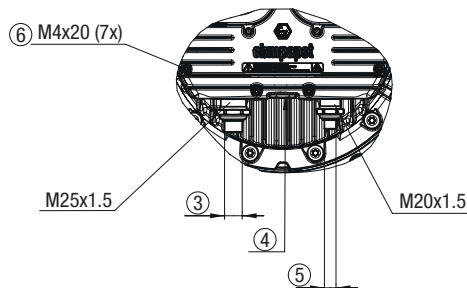
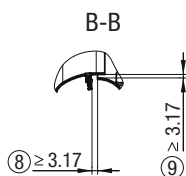
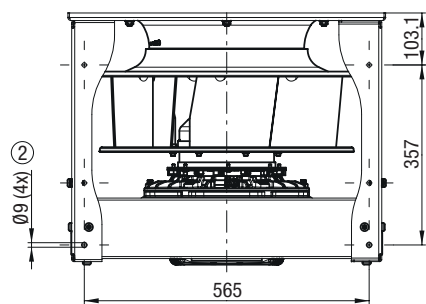

- ① Inlet ring with pressure tap
- ② Mounting position for vibration-absorbing elements
- ③ Cable gland: Cable diameter min. 10 mm, max. 16 mm, Tightening torque 6 ± 0.6 Nm, standard value depending on cable
- ④ Screw plug: M20x1.5
- ⑤ Cable gland: Cable diameter min. 10 mm, max. 14 mm, Tightening torque 6 ± 0.6 Nm standard value depending on cable
- ⑥ Terminal box fastening screws: Tightening torque: 3.5 ± 0.5 Nm
- ⑦ Ground connection point: M8 (Functional ground for electrostatic discharge, no protective earth), do not unfasten the nut provided, contact is established by way of another nut
- ⑧ Axial gap dimension
- ⑨ Radial gap dimension
- ⑩ Additional nameplate and warning sticker: in Russian

Pin assignment: (see connection diagram)
Installation position: Shaft horizontal (base mounting only) or rotor on bottom, rotor on top not permitted !

RadiPac 500 (ATEX)

C VBF0500NTTLS K3G500AP2590 (EC centrifugal module with cube design)

Dimensions in mm

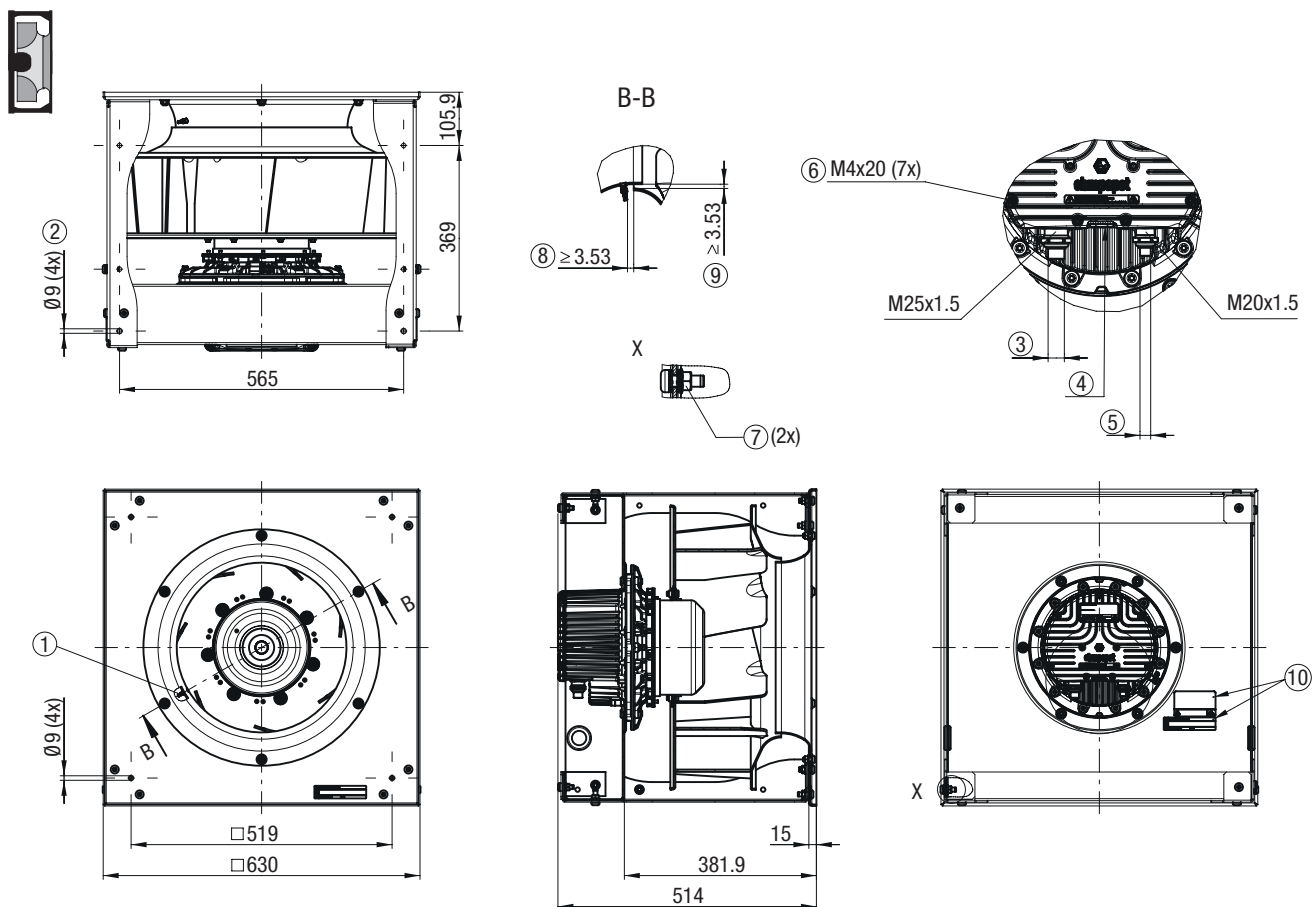

- ① Inlet ring with pressure tap
- ② Mounting position for vibration-absorbing elements
- ③ Cable gland: Cable diameter min. 10 mm, max. 16 mm, Tightening torque 6 ± 0.6 Nm, standard value depending on cable
- ④ Screw plug: M20x1.5
- ⑤ Cable gland: Cable diameter min. 10 mm, max. 14 mm, Tightening torque 6 ± 0.6 Nm standard value depending on cable
- ⑥ Terminal box fastening screws: Tightening torque: 3.5 ± 0.5 Nm
- ⑦ Ground connection point: M8 (Functional ground for electrostatic discharge, no protective earth), do not unfasten the nut provided, contact is established by way of another nut
- ⑧ Axial gap dimension
- ⑨ Radial gap dimension
- ⑩ Additional nameplate and warning sticker: in Russian

Pin assignment: (see connection diagram)

Installation position: Shaft horizontal (base mounting only) or rotor on bottom, rotor on top not permitted !

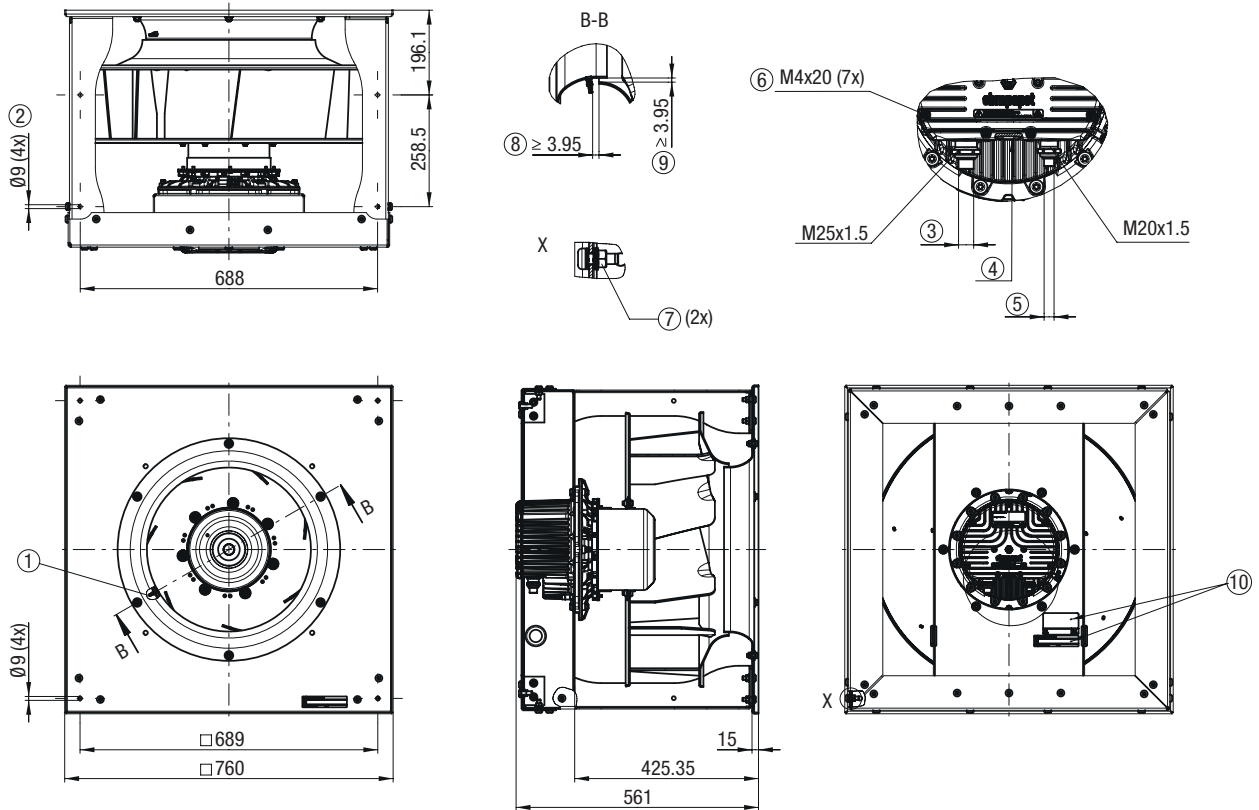

- ① Inlet ring with pressure tap
- ② Mounting position for vibration-absorbing elements
- ③ Cable gland: Cable diameter min. 10 mm, max. 16 mm, Tightening torque 6 ± 0.6 Nm, standard value depending on cable
- ④ Screw plug: M20x1.5
- ⑤ Cable gland: Cable diameter min. 10 mm, max. 14 mm, Tightening torque 6 ± 0.6 Nm standard value depending on cable
- ⑥ Terminal box fastening screws: Tightening torque: 3.5 ± 0.5 Nm
- ⑦ Ground connection point: M8 (Functional ground for electrostatic discharge, no protective earth), do not unfasten the nut provided, contact is established by way of another nut
- ⑧ Axial gap dimension
- ⑨ Radial gap dimension
- ⑩ Additional nameplate and warning sticker: in Russian

Pin assignment: (see connection diagram)
Installation position: Shaft horizontal (base mounting only) or rotor on bottom, rotor on top not permitted !

RadiPac 630 (ATEX)

E VBF0630NTTRS K3G630AP0190 (EC centrifugal module with cube design)

Dimensions in mm

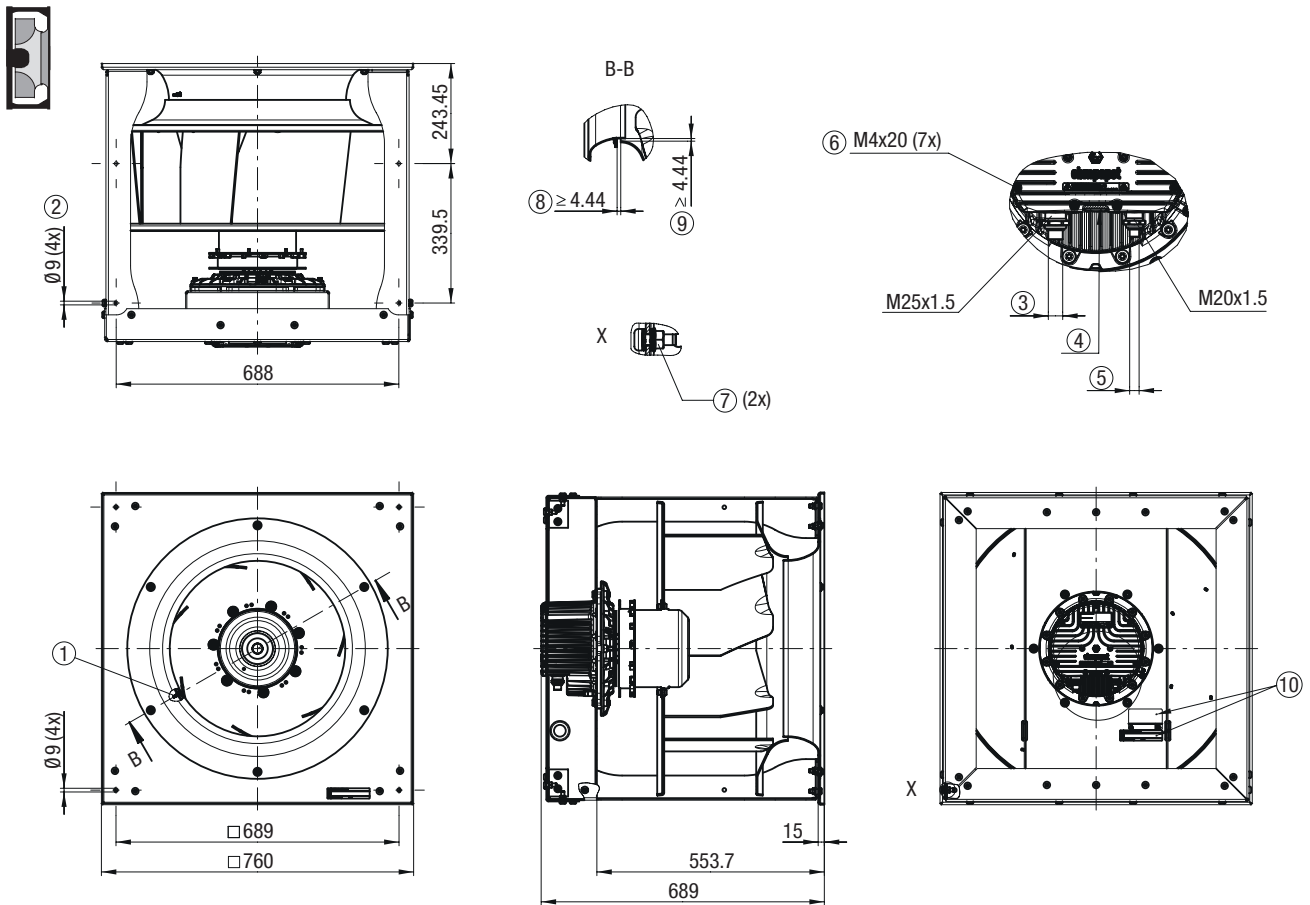

- ① Inlet ring with pressure tap
- ② Mounting position for vibration-absorbing elements
- ③ Cable gland: Cable diameter min. 10 mm, max. 16 mm, Tightening torque 6 ± 0.6 Nm, standard value depending on cable
- ④ Screw plug: M20x1.5
- ⑤ Cable gland: Cable diameter min. 10 mm, max. 14 mm, Tightening torque 6 ± 0.6 Nm standard value depending on cable
- ⑥ Terminal box fastening screws: Tightening torque: 3.5 ± 0.5 Nm
- ⑦ Ground connection point: M8 (Functional ground for electrostatic discharge, no protective earth), do not unfasten the nut provided, contact is established by way of another nut
- ⑧ Axial gap dimension
- ⑨ Radial gap dimension
- ⑩ Additional nameplate and warning sticker: in Russian

Pin assignment: (see connection diagram)

Installation position: Shaft horizontal (base mounting only) or rotor on bottom, rotor on top not permitted !

EC centrifugal fans RadiFit:

Compact, efficient, easily upgraded. Our RadiFit range of centrifugal fans with scroll housing and backward-curved blades is the new system solution for many applications in industry and ventilation technology. Thanks to the highly efficient GreenTech EC motors, it offers high efficiency at high pressures. They are also extremely compact, robust and light. Best of all, RadiFit fans match the standard installation dimensions for fans. This makes installing and replacing them child's play. Fits, saves and makes sense!

Retrofit: replace with highly efficient technology.

Energy efficiency means lower operating costs.

Our centrifugal fans with GreenTech EC technology are so much more advanced than normal fans, that even retrofitting existing units quickly pays for itself. Furthermore, our new range has a particularly long service life and requires no maintenance at all, which results in further cuts to operating and life cycle costs.

Finally, we deliver the fans complete with housing and installed controlled electronics (VSD). This also reduces your installation costs to a minimum.

Comparing this to an obsolete belt drive and a flange-mounted motor makes the difference clear to see. Instead of connecting multiple components to each other at great effort and expense, RadiFit has everything integrated already, combined with minimal size and maximum energy efficiency.

Typical applications in air conditioning:

- Low profile air conditioning unit with RadiFit 250
- Central air handling unit with RadiFit 400

Typical industrial implementation:

- Generator cooling with RadiFit 310

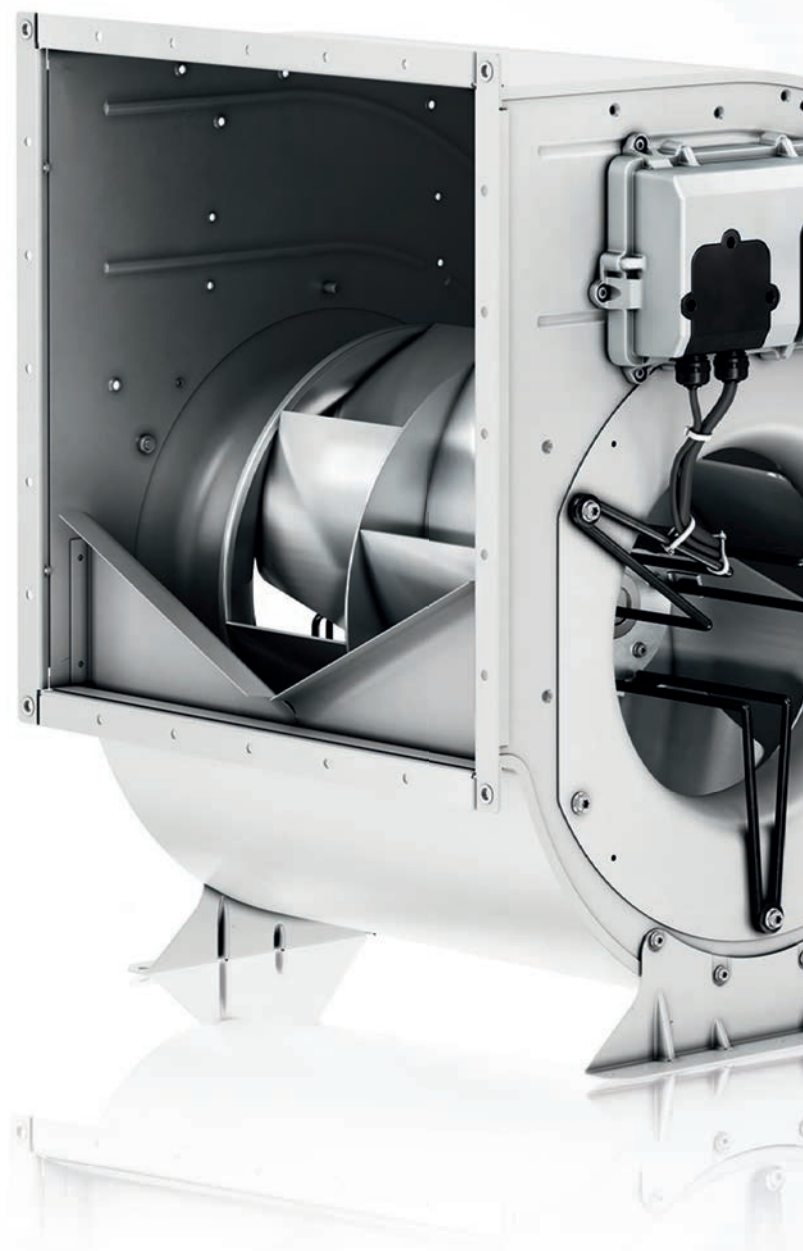

RadiFit 250 - 400

ebmpapst

engineering a better life



	Page
Tender specification	142
250 - 400	144

Tender specification

EC centrifugal fans - RadiFit

Fan size 250 to 400

Direct-drive dual-inlet centrifugal fans with backward-curved high-performance centrifugal impellers mounted on a GreenTech EC external rotor motor with add-on control electronics.

Scroll housing made of galvanised sheet steel with bolted -on adjustable mounting bracket, optimised step diffuser in discharge for low-noise operation, connection flange on pressure side.

aluminum impeller with 7 backward-curved, offset, continuously welded blades. Flow-optimised inlet nozzle made of galvanised sheet steel.

Motorized impeller balanced in two planes (static and dynamic) as per DIN ISO 21940 to balance quality G 6.3.

GreenTech EC external rotor motor surpasses efficiency class IE4, magnets without use of rare earths, maintenance-free ball bearings with long-term lubrication, theoretical nominal service life of at least 40.000 operating hours, soft start, integrated current limitation, wide input voltage range 3-phase 380-480 V, 50/60 Hz, fan suitable for use with all standard power supply systems with no effect on air performance.

Motorised impeller isolated from surroundings with specially designed vibration-absorbing elements, compact electronics, aluminum housing, low-noise commutation logic; 100% speed control; PID controller; RS485/MODBUS RTU interface, no need for shielded wiring.

Readily accessible connection area with spring terminals, cable entry can be moved through 180 degrees, environment-resistant cable glands.

Fan satisfies the relevant EMC regulations and requirements with regard to circuit feedback; documentation and marking conform to the applicable EU directives

Reliable performance data, air performance measurements on inlet-side chamber test rig in accordance with ISO 5801 and DIN 24163, noise measurements in low-reflection acoustic test chamber as per DIN EN ISO 3745.

Integrated protective devices:

- Alarm relay with floating contacts (250 V AC/2 A, $\cos \varphi = 1$)
- Locked-rotor protection
- Phase failure detection
- Motor soft start
- Mains undervoltage detection
- Excess temperature protection for electronics and motor
- Short circuit protection

Optional:

- Different requirements on request

Tender specification

EC centrifugal fans - RadiFit

Fan size 250 to 400

Technical data:

Fan type		= D3G_____ - _____ - _____
Air flow	qV	= _____ m ³ /h, cfm
Stat. pressure increase	pfs	= _____ Pa, in wg
Stat. overall efficiency	η_{es}	= _____ %
Operating speed	n	= _____ rpm
Motor type		= EC motor
Type of control		= 0-100 % speed control
Motor efficiency class		= IE4
Total power input	Ped	= _____ kW
Specific fan power	SFP	= _____ kW/(m ³ /s)
Nominal voltage range	U _N	= _____ V
Line frequency	f	= 50 / 60 Hz
Nominal current	I _N	= _____ A
Degree of protection		= IP54
Sound power level	L _{WA} (A, in)	= _____ / L _{WA} (A, out) = _____ dB(A)
Sound pressure level (at 1 m)	L _{pA} (A, in)	= _____ / L _{pA} (A, out) = _____ dB(A)
Perm. ambient temperature	T	= _____ to _____ °C
Weight of fan	m	= _____ kg



EC centrifugal fans - RadiFit
With scroll housing
Fan size 250 - 400

Refer to data sheet for dimensions and wiring.

RadiFit 250 - 400

EC centrifugal fans, backward curved, with housing



Material/surface

- Housing: Sheet steel, galvanized
- Impeller: Sheet aluminum
- Rotor: Painted black
- Electronics housing: Die-cast aluminum

Mechanical characteristics

- Motor suspension: Motor mounted with brackets on one side
- Direction of rotation: Clockwise viewed toward rotor
- Installation position: See product drawing
- Condensation drainage holes: Rotor side
- Mode: Continuous operation (S1)
- Mounting: Maintenance-free ball bearings

Further Information





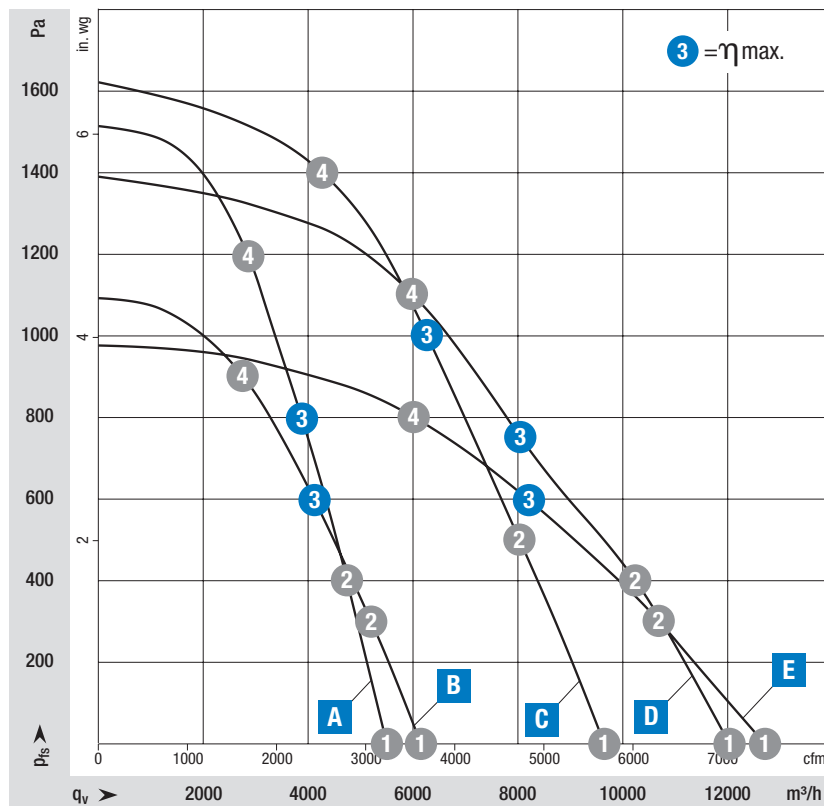



- Information about touch current, electrical connection, degree of protection, insulation class, environmental protection class, EMC standards as well as standards and approvals can be found in the product-specific data sheets.

on Page 146	Drawings
on Page 154	Accessories
on Page 166	Connection diagrams and technical features
on Page 172	Technical parameters & scope
More at	www.ebmpapst.com/worldwide www.ebmpapst.com/radipac



Measuring requirements

Air performance measured according to: ISO 5801, installation category A, with ebm-papst inlet ring without contact protection. Intake-side sound level: L_{pA} according to 13347, L_{pA} measured at 1 m distance from fan axis. The values given are only applicable under the specified measuring conditions and may differ depending on the installation conditions. In the event of deviation from the standard configuration, the parameters must be checked in installed condition.

Curve				Operating point	Nominal voltage	Speed n	Max. Input power P_{in}	Max. Input current I	Sound power level LWA	Perm. ambient temp.	Degree of protection	Conn. diagram	
Nominal voltage range 3-380-480 V AC, 50/60 Hz				VAC	rpm	W	A	dB(A)	°C				
Type	Part number	Fan type											
A	VCD0250FTPMS	D3G250GG0901	RadiFit	 Mounting bracket	①	400	3850	1610	2,57	96	-25..+40	IP 54	RP7)
					②	400	3850	1765	2,79	94			
					③	400	3850	1810	2,90	91			
					④	400	3850	1720	2,73	89			
					---	---							
B	VCD0280FTPMS	D3G280GG1001	RadiFit	 Mounting bracket	①	400	2900	1190	1,98	92	-40..+40	IP 54	RP7)
					②	400	2900	1295	2,10	89			
					③	400	2900	1320	2,10	86			
					④	400	2900	1190	1,98	85			
					---	---							
C	VCD0310FTRNS	D3G310GG0501	RadiFit	 Mounting bracket	①	400	3140	2825	4,35	97	-25..+40	IP 54	RP7)
					②	400	3140	3095	4,74	95			
					③	400	3140	3180	4,90	91			
					④	400	3140	2810	4,32	90			
					VCD0310FTRNS	D3G310GG0504	RadiFit	 Mounting frame	①	400			
②	400	3140	2810	4,32					90				
③	400	3140	2810	4,32					90				
④	400	3140	2810	4,32					90				
---	---												
D	VCD0355FTRNS	D3G355GG0301	RadiFit	 Mounting bracket	①	400	2600	2980	4,59	95	-25..+40	IP 54	RP7)
					②	400	2600	3160	4,90	93			
					③	400	2600	3160	4,90	91			
					④	400	2600	3040	4,68	89			
					VCD0355FTRNS	D3G355GG0304	RadiFit	 Mounting frame	①	400			
②	400	2600	3040	4,68					89				
③	400	2600	3040	4,68					89				
④	400	2600	3040	4,68					89				
---	---												
E	VCD0400FTRNS	D3G400GG0401	RadiFit	 Mounting bracket	①	400	1920	2170	3,39	91	-25..+40	IP 54	RP7)
					②	400	1920	2380	3,70	88			
					③	400	1920	2380	3,70	85			
					④	400	1920	2160	3,38	84			
					VCD0400FTRNS	D3G400GG0404	RadiFit	 Mounting frame	①	400			
②	400	1920	2160	3,38					84				
③	400	1920	2160	3,38					84				
④	400	1920	2160	3,38					84				
---	---												

Subject to change

Values set in blue are nominal data at operating point with maximum load.

RadiFit 250

A VCD0250FTPMS D3G250GG0901 (EC centrifugal fan - RadiFit with mounting bracket)

Dimensions in mm

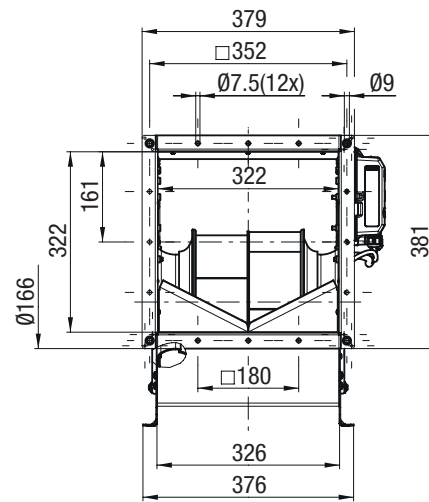
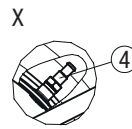
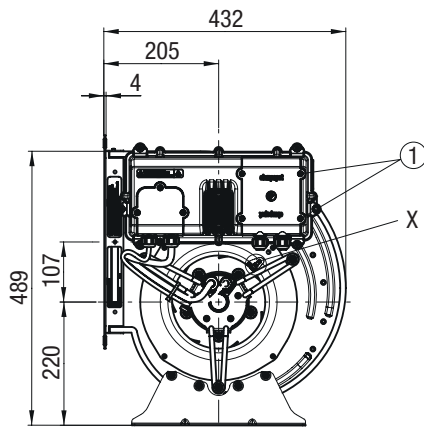
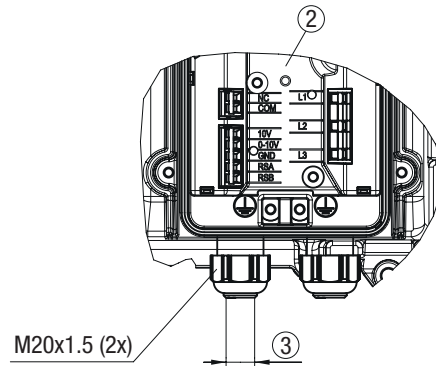
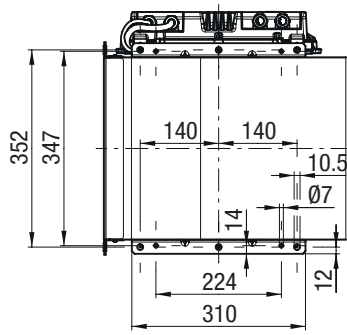

- ① Tightening torque: 3.5 ± 0.5 Nm
- ② Terminal box: Pin assignment see connection diagram
- ③ Cable gland: Cable diameter min. 8 mm, max. 12 mm, Tightening torque 1.8 ± 0.3 Nm,
- ④ Inlet ring: with pressure tap (k-factor: 134) on both sides

Installation position: Shaft horizontal or rotor on bottom, rotor on top on request

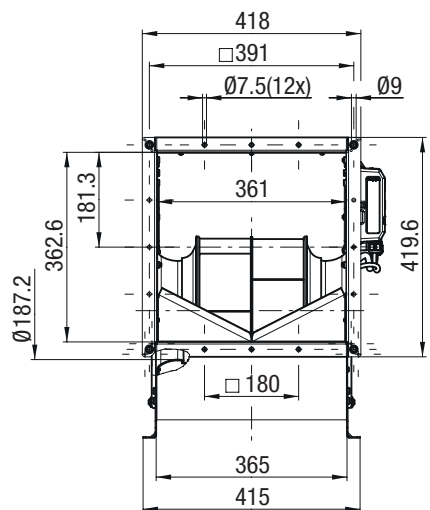
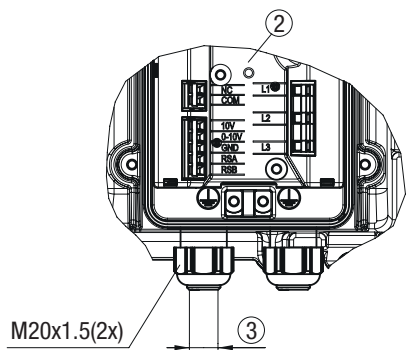
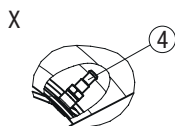
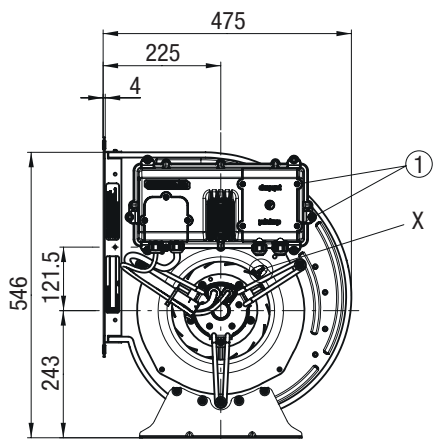
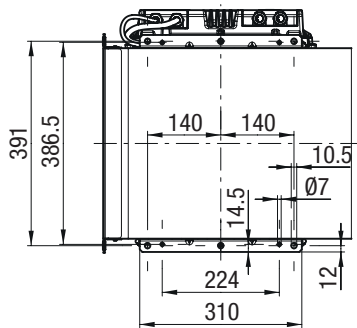

- ① Tightening torque: 3.5 ± 0.5 Nm
- ② Terminal box: Pin assignment see connection diagram
- ③ Cable gland: Cable diameter min. 8 mm, max. 12 mm, Tightening torque 1.8 ± 0.3 Nm,
- ④ Inlet ring: with pressure tap (k-factor: 175) on both sides

Installation position: Shaft horizontal or rotor on bottom, rotor on top on request

RadiFit 310

C VCD0310FTRNS D3G310GG0501 (EC centrifugal fan - RadiFit with mounting bracket)

Dimensions in mm

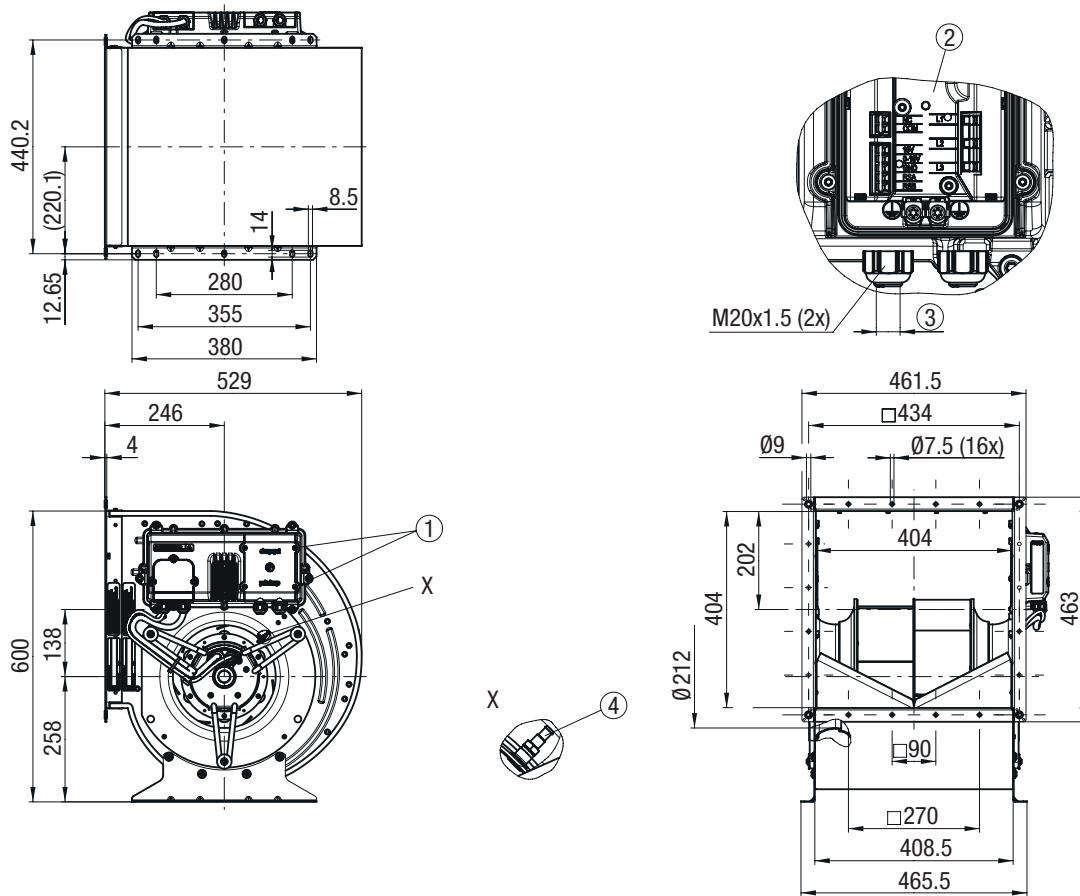
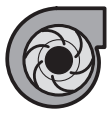

- ① Tightening torque: 3.5 ± 0.5 Nm
- ② Terminal box: Pin assignment see connection diagram
- ③ Cable gland: Cable diameter min. 8 mm, max. 12 mm, Tightening torque 1.8 ± 0.3 Nm,
- ④ Inlet ring: with pressure tap (k-factor: 206) on both sides

Installation position: Shaft horizontal or rotor on bottom, rotor on top on request

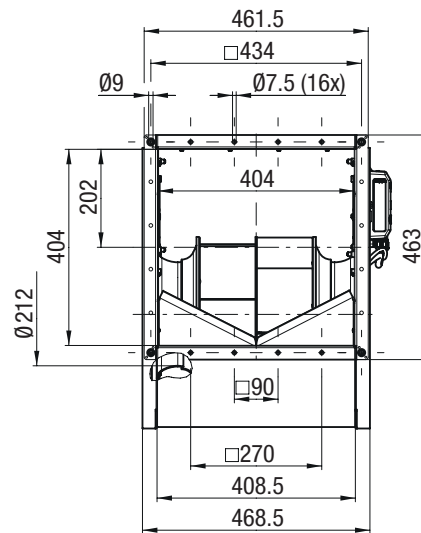
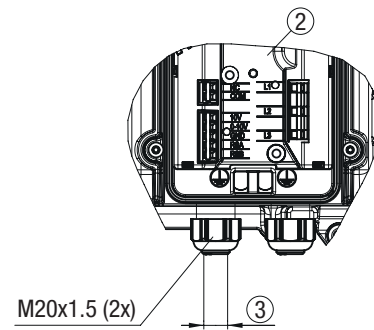
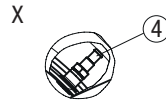
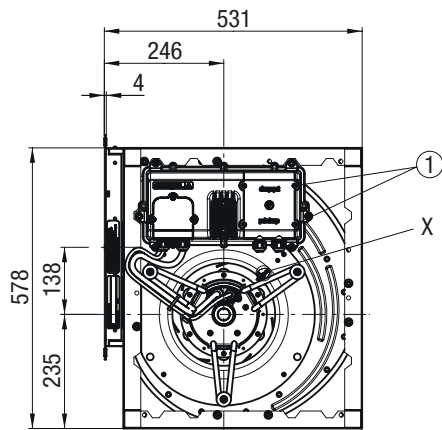
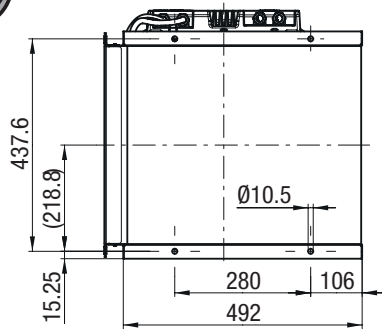
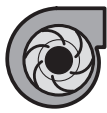

- ① Tightening torque: 3.5 ± 0.5 Nm
- ② Terminal box: Pin assignment see connection diagram
- ③ Cable gland: Cable diameter min. 8 mm, max. 12 mm, Tightening torque 1.8 ± 0.3 Nm,
- ④ Inlet ring: with pressure tap (k-factor: 206) on both sides

Installation position: Shaft horizontal or rotor on bottom, rotor on top on request

RadiFit 355

D VCD0355FTRNS D3G355GG0301 (EC centrifugal fan - RadiFit with mounting bracket)

Dimensions in mm

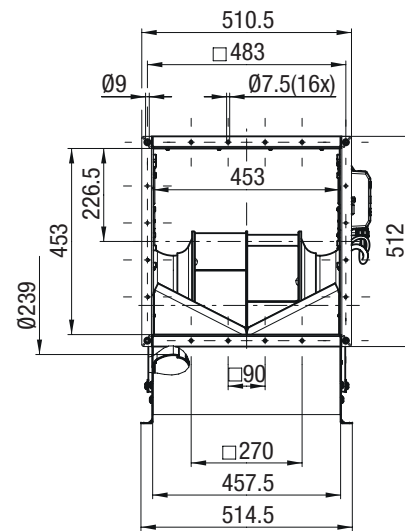
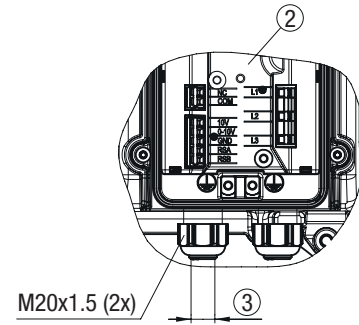
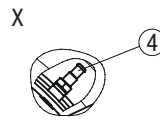
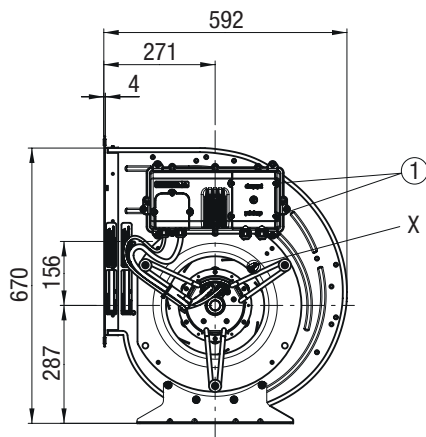
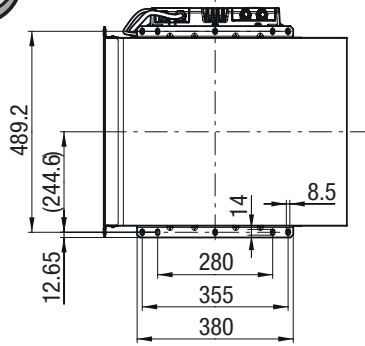
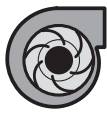

- ① Tightening torque: 3.5 ± 0.5 Nm
- ② Terminal box: Pin assignment see connection diagram
- ③ Cable gland: Cable diameter min. 8 mm, max. 12 mm, Tightening torque 1.8 ± 0.3 Nm,
- ④ Inlet ring: with pressure tap (k-factor: 277) on both sides

Installation position: Shaft horizontal or rotor on bottom, rotor on top on request

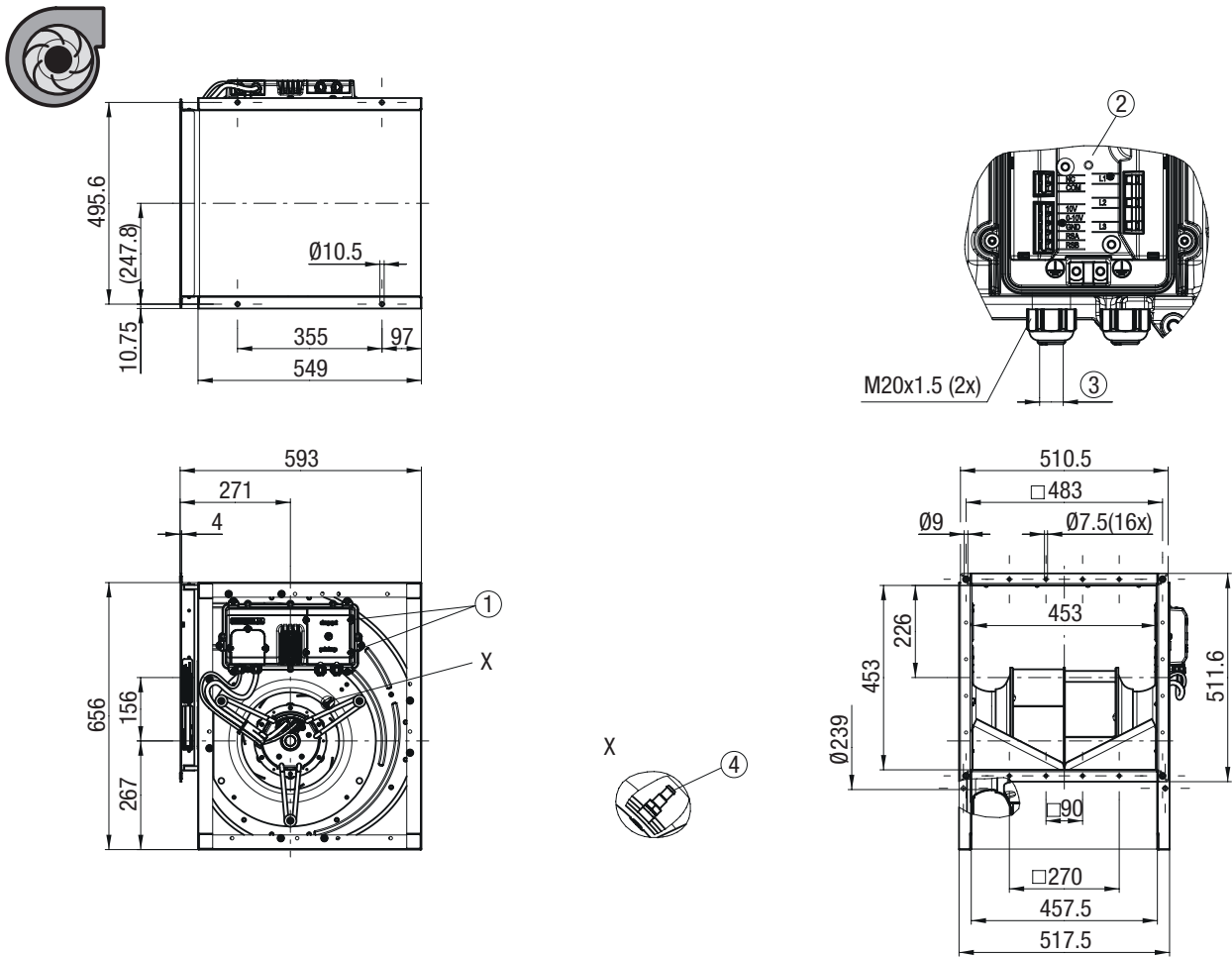

- ① Tightening torque: 3.5 ± 0.5 Nm
- ② Terminal box: Pin assignment see connection diagram
- ③ Cable gland: Cable diameter min. 8 mm, max. 12 mm, Tightening torque 1.8 ± 0.3 Nm,
- ④ Inlet ring: with pressure tap (k-factor: 277) on both sides

Installation position: Shaft horizontal or rotor on bottom, rotor on top on request

RadiFit 400

E VCD0400FTRNS D3G400GG0401 (EC centrifugal fan - RadiFit with mounting bracket)

Dimensions in mm

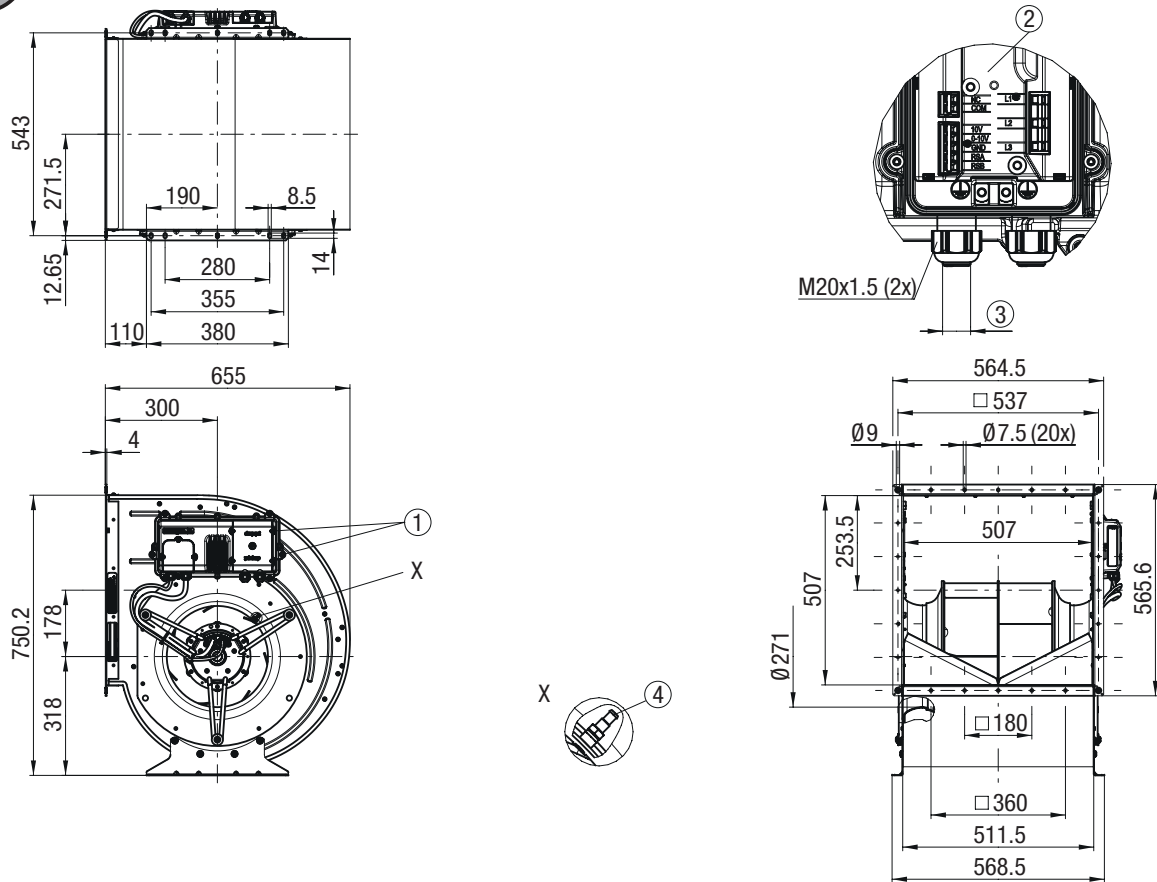

- ① Tightening torque: 3.5 ± 0.5 Nm
- ② Terminal box: Pin assignment see connection diagram
- ③ Cable gland: Cable diameter min. 8 mm, max. 12 mm, Tightening torque 1.8 ± 0.3 Nm,
- ④ Inlet ring: with pressure tap (k-factor: 355) on both sides

Installation position: Shaft horizontal or rotor on bottom, rotor on top on request

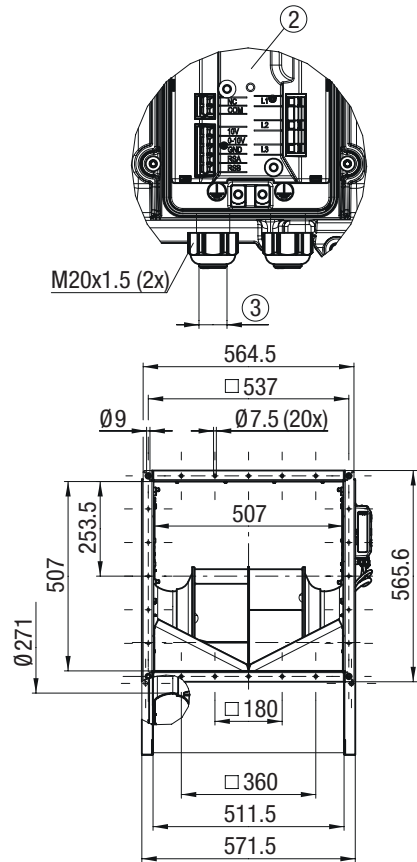
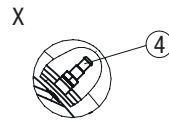
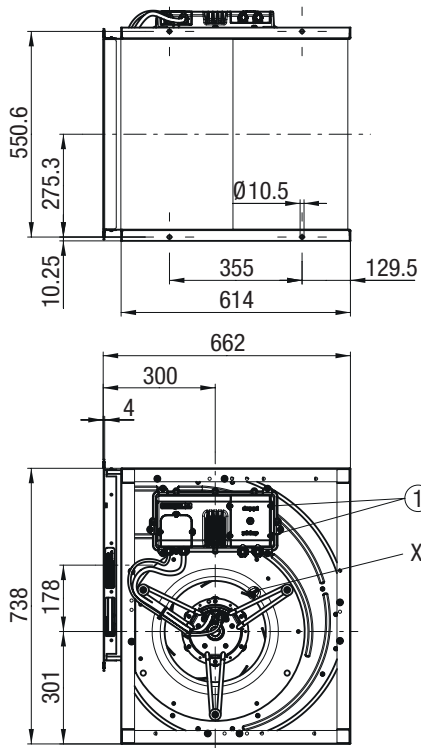

- ① Tightening torque: 3.5 ± 0.5 Nm
- ② Terminal box: Pin assignment see connection diagram
- ③ Cable gland: Cable diameter min. 8 mm, max. 12 mm, Tightening torque 1.8 ± 0.3 Nm,
- ④ Inlet ring: with pressure tap (k-factor: 355) on both sides

Installation position: Shaft horizontal or rotor on bottom, rotor on top on request

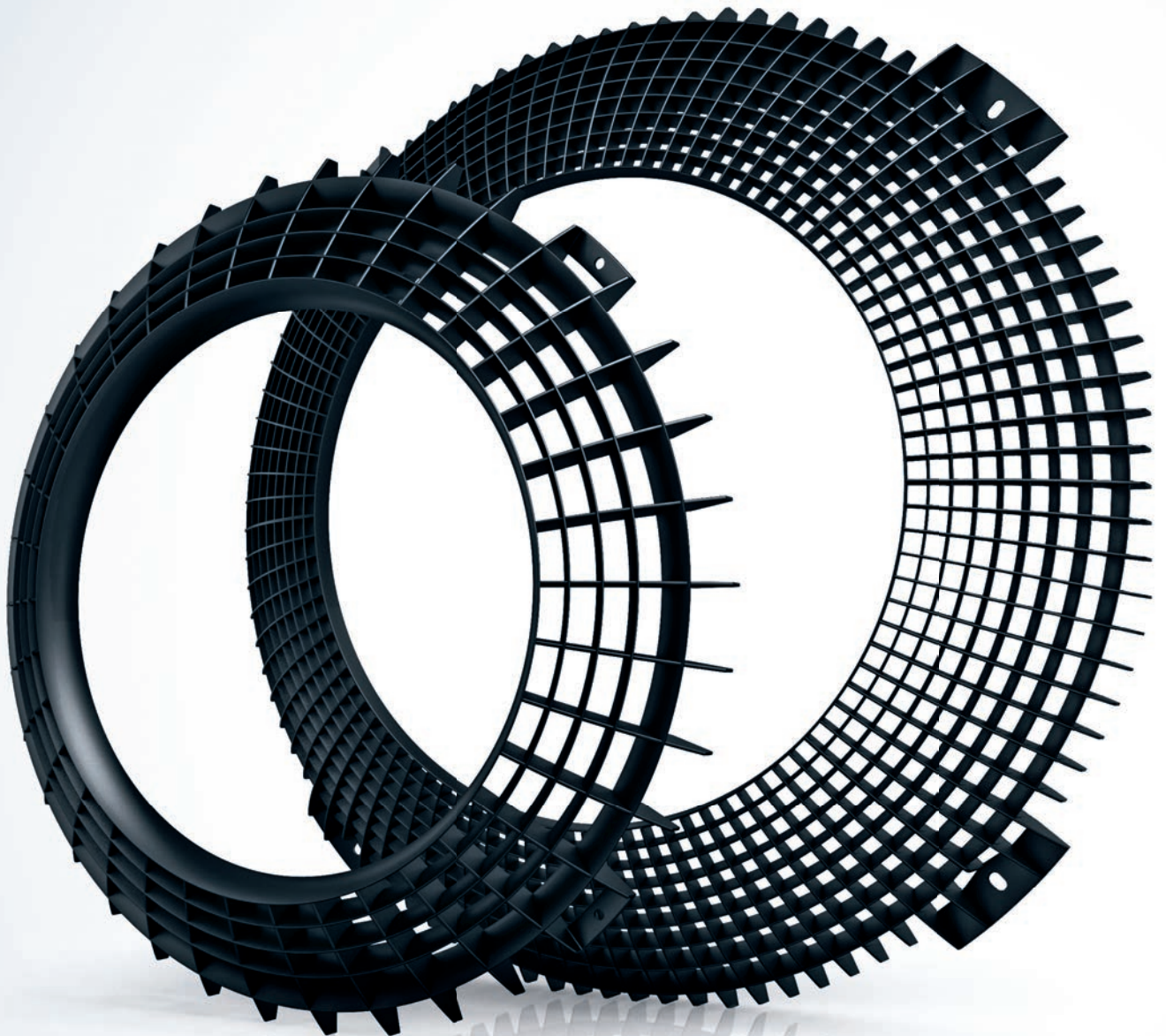

Accessories

for EC centrifugal fans - RadiPac

ebmpapst

engineering a better life

	Page
FlowGrid air inlet grill	156
Intake finger guard	157
Inlet rings	158
Vibration absorbers	162

FlowGrid air inlet grill

efficient noise reduction



ebm-papst fans are not measured on our own advanced test stands just for their air performance alone. The acoustic behavior of the fans is also examined and the measurement results are included in the technical documentation.

Please note that the measurements are taken under ideal conditions with undisturbed inflow and out-flow. If the fans are subsequently installed and used in devices with rather tight spaces, it is to be expected that the noise data provided in the documentation will not be applicable.

In order to minimize the negative impact of the installation situation, ebm-papst offers the FlowGrid air-inlet guard shown here. It is installed on the intake side of the fan and effectively reduces the noise generated by the fan. Particularly annoying, low-frequency noises are reduced efficiently.

The level of noise reduction is dependent on the installation situation, which is why no generally applicable data is possible here.

FlowGrid air inlet grill

Part number	Fan size	Ø B (mm)	Ø C (mm)	Ø E (mm)	S (mm)	H (mm)	N* (Nm)
20280-2-2957	250, 280	280	245-261	4,5	3,5	40	2±0,5
25310-2-2957	310	315	288-292	5,5	3,5	49	2±0,5
00400-2-2957	355	370	334-346	4,5	3,5	56	2±0,5
35505-2-2957	400, 450, 500	470	440	9,0	3,5	71	10±2
00630-2-2957	560, 630	580	545	10	3,0	90	10±2
50710-2-2957	710	666	630	10	3,0	106	10±2
63000-2-2957	800	785	750	10	3,0	125	10±2

Subject to change

* Recommended tightening torque for fastening screws

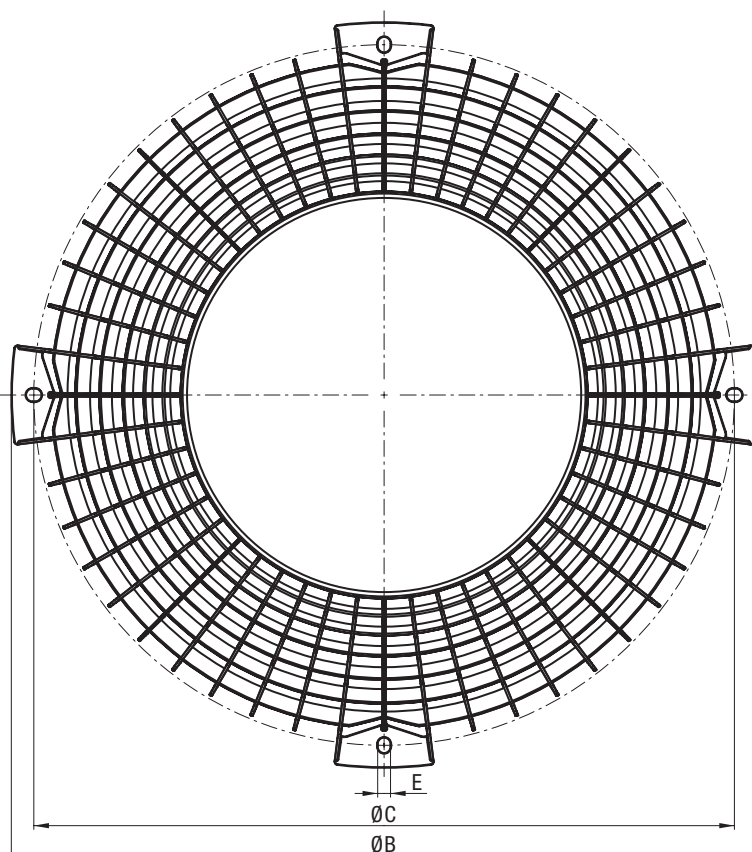

Would you like to find out more?

If you need an installation guide or more information about the dimensions, go to:

www.ebmpapst.com/flowgrid-manual

or scan the QR code below:



Intake finger guard

Wire mesh finger guard

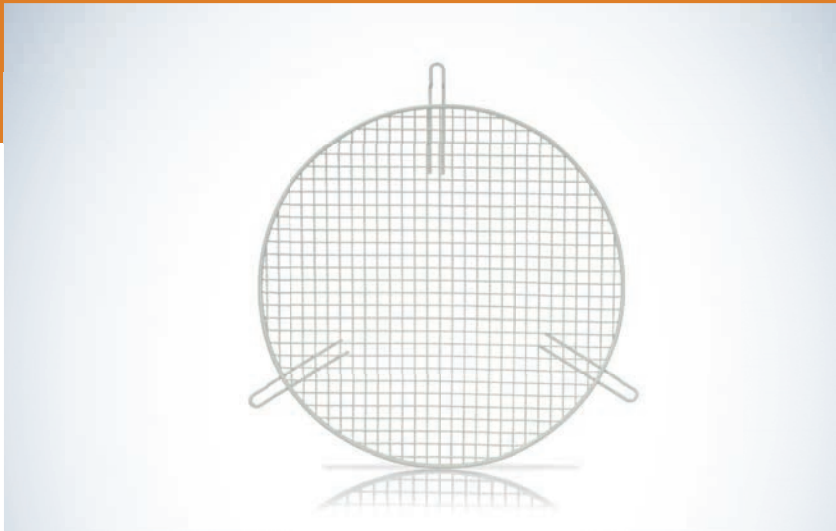

- **Material:** Steel wire, phosphated,
 Versions 1 and 2:
 Painted pebble gray (RAL 7032)
 Versions 3 and 4:
 Painted light gray (RAL 7035)

Intake finger guard for backwards-curved centrifugal fans (according to EN ISO 13857)

Part number	Fan size	Version	a (mm)	b (mm)	d (mm)	e (mm)	Strut division
79280-2-4039	250,280	1	280	4,5	227	2,8	4 x 90°
79310-2-4039	310	1	325	4,5	271	2,8	4 x 90°
79355-2-4039	355	1	345	4,5	308	2,8	4 x 90°
79400-2-4039	400	2	390	8,5	343	2,8	3 x 120°
79500-2-4039	450,500	2	445	8,5	417	2,8	3 x 120°
79560-2-4039	560	2	490	8,5	466	2,8	3 x 120°
79630-2-4039	630	3	600	8,5	551	3,9	3 x 120°
79710-2-4039	710, 800	3	700	8,5	651	3,9	3 x 120°
79900-2-4039	1000	4	850	8,5	801	3,9	6 x 60°

Subject to change

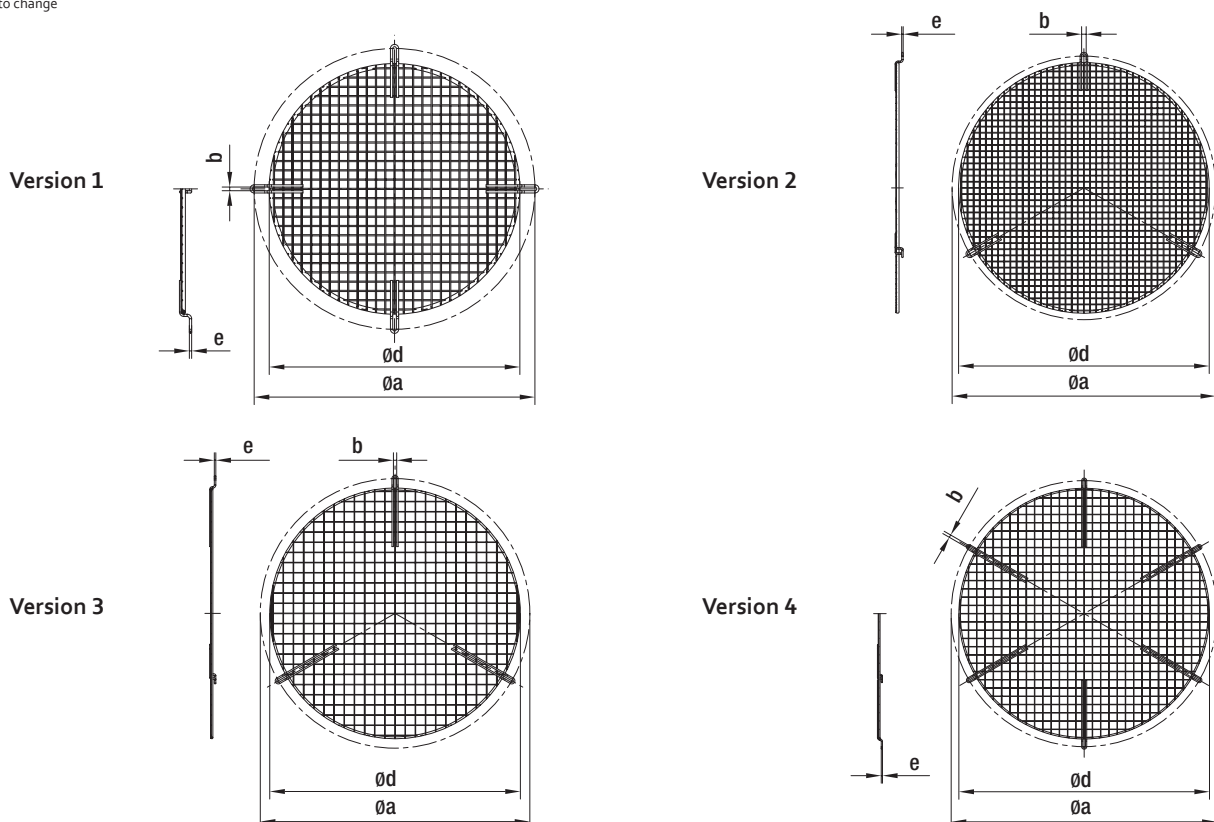

Inlet rings

with / without measuring device



– **Material:** Galvanized sheet steel

Inlet rings with / without measuring device to determine the air flow for backwards-curved centrifugal fans

Part number without measuring device	Part number with one pressure tap	Part number with piezometer	Fan size	Dimensions / drawing
96350-2-4013	96355-2-4013	96345-2-4013	250	see Page 159
28000-2-4013	28004-2-4013	28003-2-4013	280	see Page 159
31470-2-4013	31475-2-4013	31480-2-4013	310	see Page 159
35670-2-4013	35675-2-4013	35680-2-4013	355	see Page 159
40073-2-4013	40075-2-4013	40083-2-4013	400	see Page 160
45070-2-4013	45075-2-4013	45080-2-4013	450	see Page 160
63072-2-4013	64025-2-4013	64002-2-4013	500	see Page 160
63071-2-4013	64030-2-4013	64001-2-4013	560	see Page 160
63070-2-4013	64040-2-4013	64000-2-4013	630	see Page 161
71070-2-4013	71075-2-4013	71080-2-4013	710	see Page 161
80070-2-4013	80075-2-4013	80080-2-4013	800	see Page 161

Subject to change

without
measuring device:

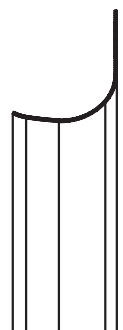

with one
pressure tap:



with
piezometer:

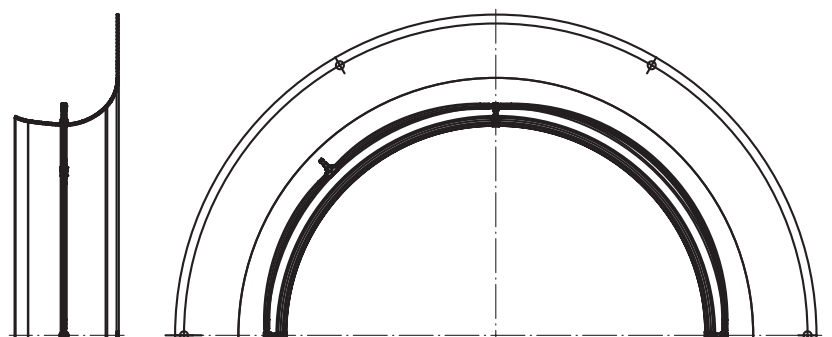

Inlet rings

Dimensioned drawings with one pressure tap

Fan size 250:

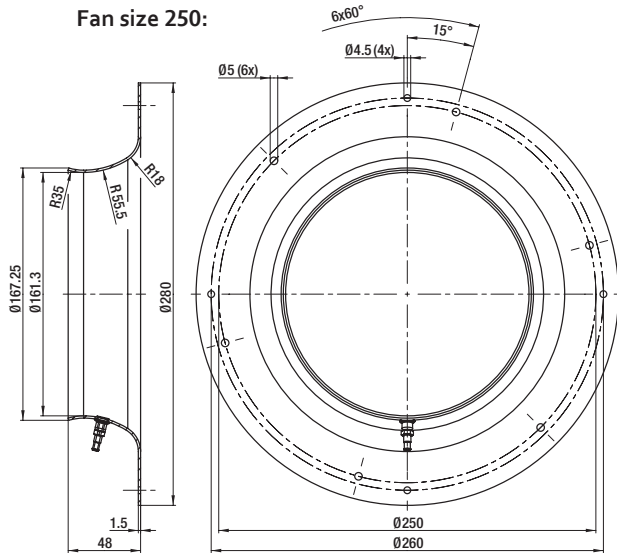

Fan size 280:

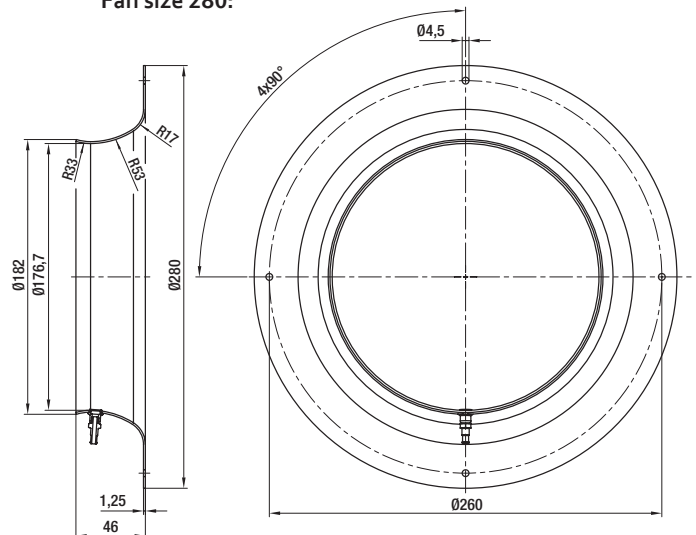

Fan size 310:

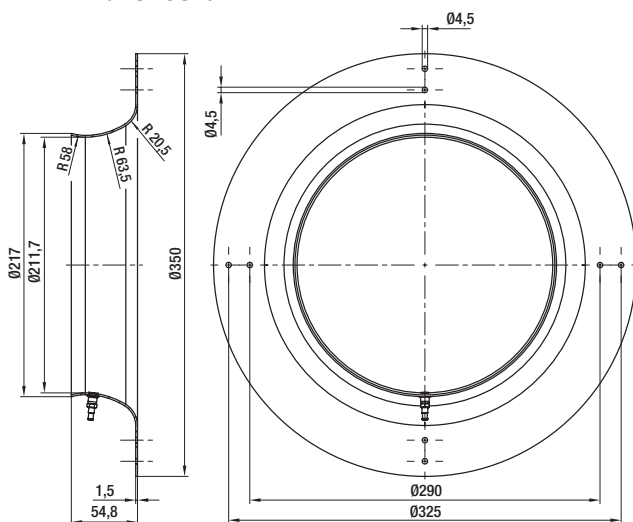

Fan size 355:

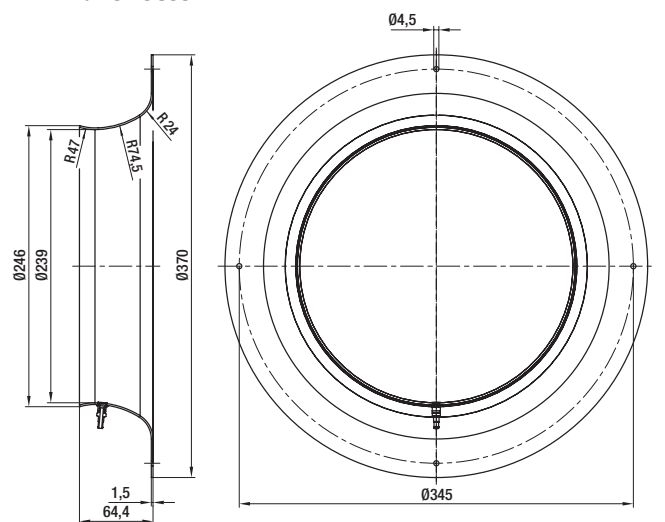

Inlet rings

Dimensioned drawings with one pressure tap

Fan size 400:

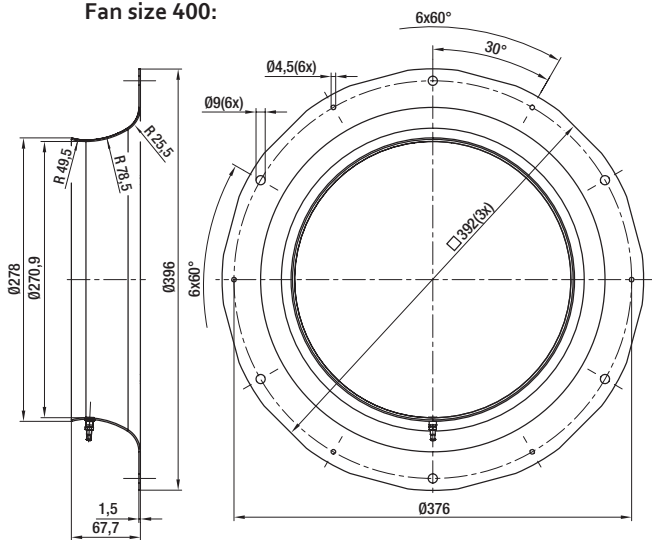

Fan size 450:

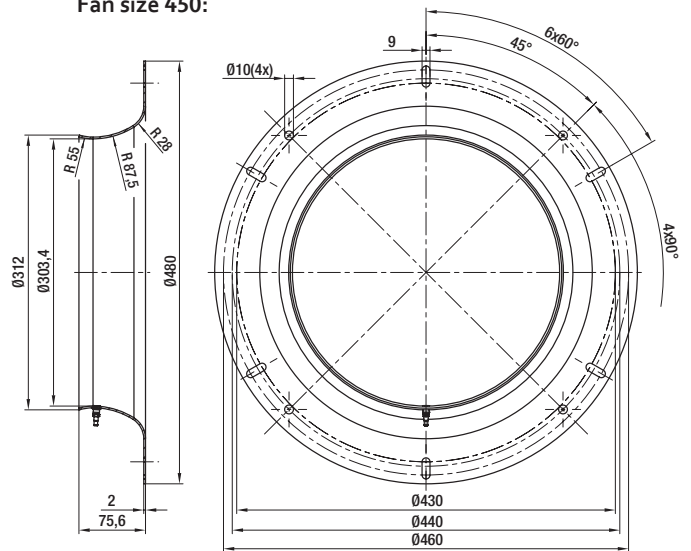

Fan size 500:

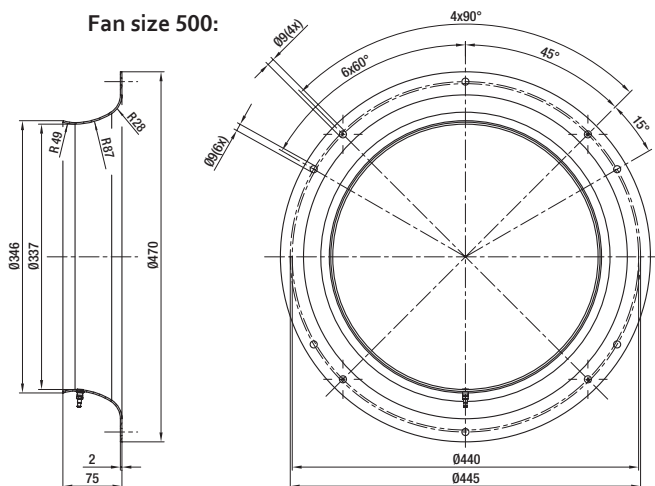

Fan size 560:

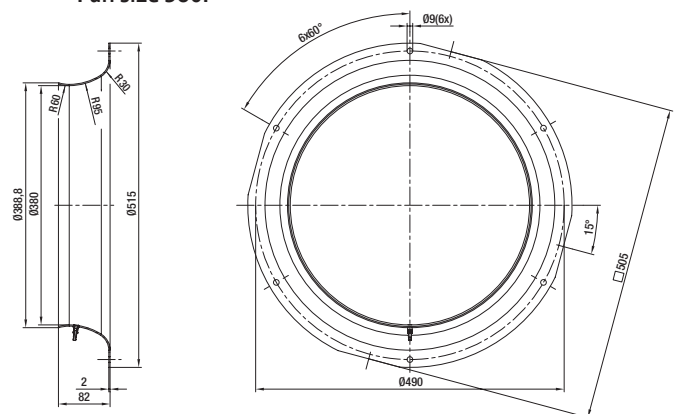

Inlet rings

Dimensioned drawings with one pressure tap

Fan size 630:

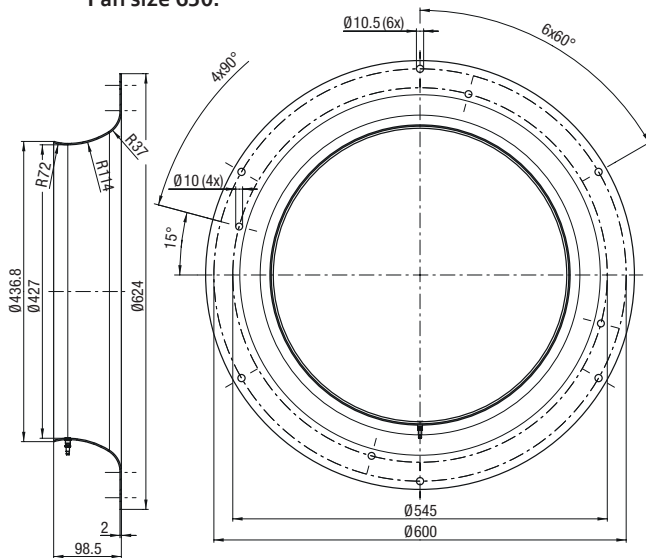

Fan size 710:

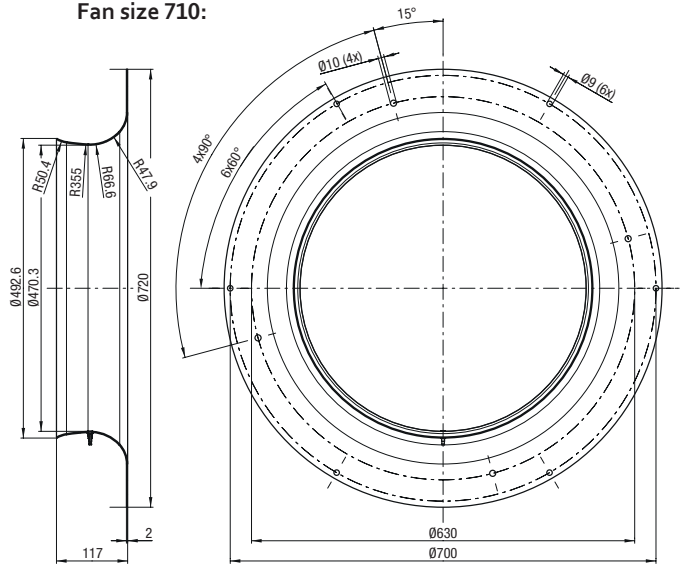

Fan size 800:

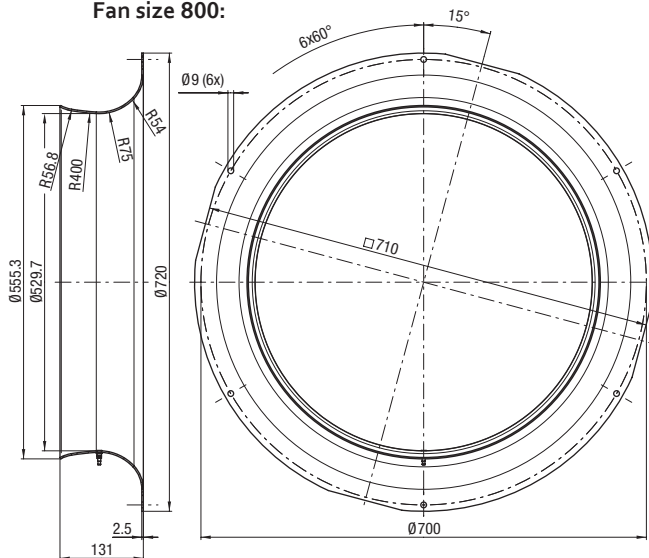

Vibration absorbers

for EC centrifugal fans - RadiPac

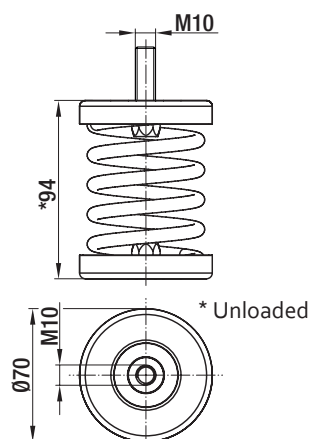

– Packaging:

Part numbers refer to one set consisting of 4x spring elements each.
Supplied in a box.

– For further information, see: Installation instructions no.: 45014-4-8670

Vibration absorbers (steel)

Part number (Set)	Type	Minimum speed (rpm)	Deflection (mm)
11064-4-5142	K3G 630-PV04-01	510	7,5
11065-4-5142	K3G 630-PW04-01	570	5,9
11065-4-5142	K3G 710-PV05-01	530	6,5
11065-4-5142	K3G 710-PW06-01	490	7,8
11065-4-5142	K3G 800-PV13-01	500	7,4
11065-4-5142	K3G 800-PW07-01	480	8,0
11064-4-5142	K3G A00-PV03-01	370	13,8

Subject to change

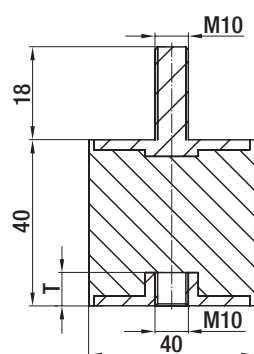

– Packaging:

Part numbers refer to one set consisting of 4x rubber buffers, washers, and nuts each.
Supplied in a box.

– For further information, see: Installation instructions no.: 45014-4-8670

Vibration absorbers (rubber)

Part number (Set)	Type	Minimum speed (rpm)	Deflection (mm)
10005-4-5164	K3G 630-PV04-01	790	2,1
10005-4-5164	K3G 630-PW04-01	725	2,5
10005-4-5164	K3G 710-PV05-01	701	2,6
10005-4-5164	K3G 710-PW06-01	629	3,3
10005-4-5164	K3G 800-PV13-01	656	3,1
10005-4-5164	K3G 800-PW07-01	620	3,4
10008-4-5164	K3G A00-PV03-01	496	5,3

Subject to change

Vibration absorbers

for EC centrifugal fans - RadiPac

Attention:

The vibration absorbers recommended by ebm-papst are available in a set of 4 pieces. The vibration absorbers are perfectly matched to their intended fans and the specified minimum speed. The installation and operation of several fans on one set of spring elements is not allowed.

During start-up, the fan has to pass through the speed range corresponding to the resonance frequency (below the minimum speed). The vibrations caused by the fan's residual imbalance are strongest within this speed range. This speed range must be passed through as quickly as possible to avoid damage to the fan. Operation below, close to or at the resonance frequency will destroy the fan!

When the fan is being operated, take care to ensure that the fan's speed does not go below the specified minimum speed. This will prevent the fan from being operated continuously near the resonance frequency. The specified minimum speed is always for an individual fan without any influences from the system it is installed in.

Installation example: Floor-mounted, shaft horizontal

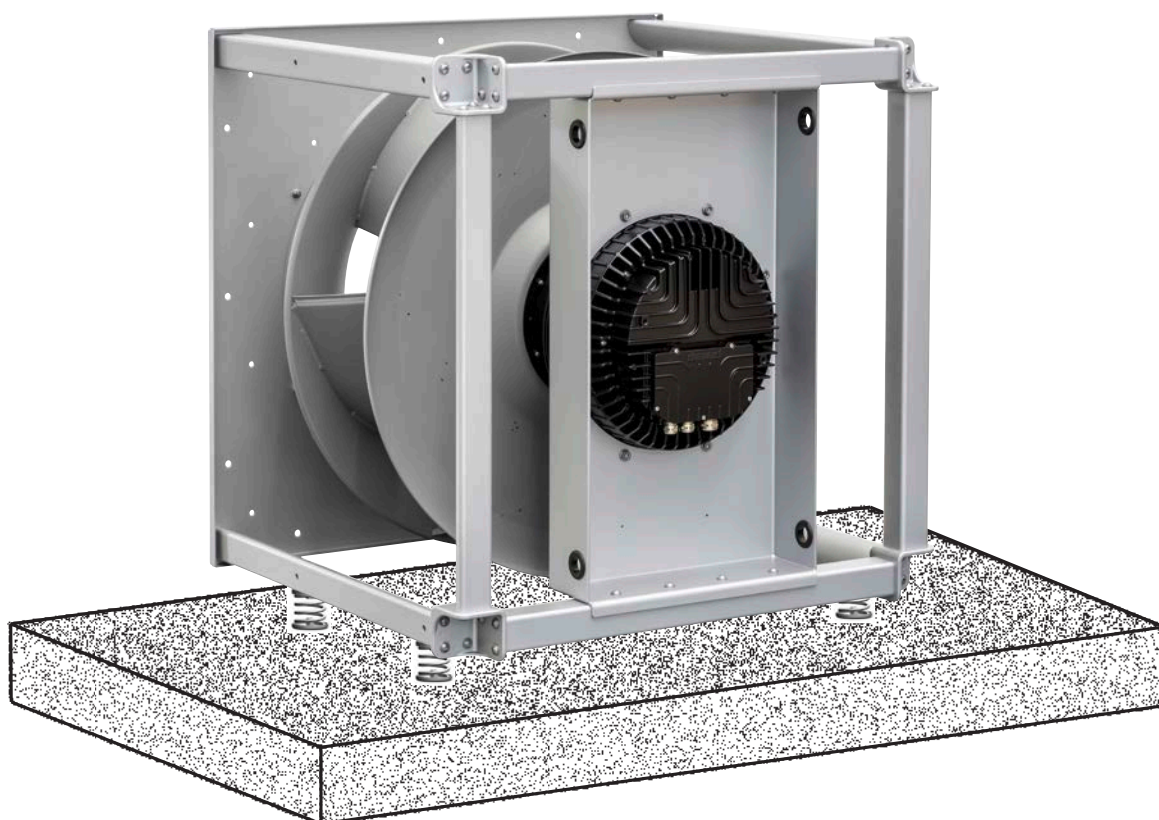

The configuration of the unit in which the fan is installed can have a strong influence on the fan's vibration characteristics, so a vibration test always has to be performed after the fan has been installed. The fan's vibration characteristics must be tested under all relevant operating conditions (such as speed, back pressure, systemic fluctuations in back pressure) – when installed and in interaction with the complete system.

The maximum vibration severity may not exceed 3.5 mm/s, measured at the motor's fastening pitch circle on the motor support plate in the direction of and perpendicular to the motor's axis of rotation. Even when the vibration absorbers recommended by ebm-papst are used, their effectiveness must be tested in the application. If vibration absorbers other than those specified are used, tests must be performed to determine how the resonance frequency, and thus the operating requirements, change.

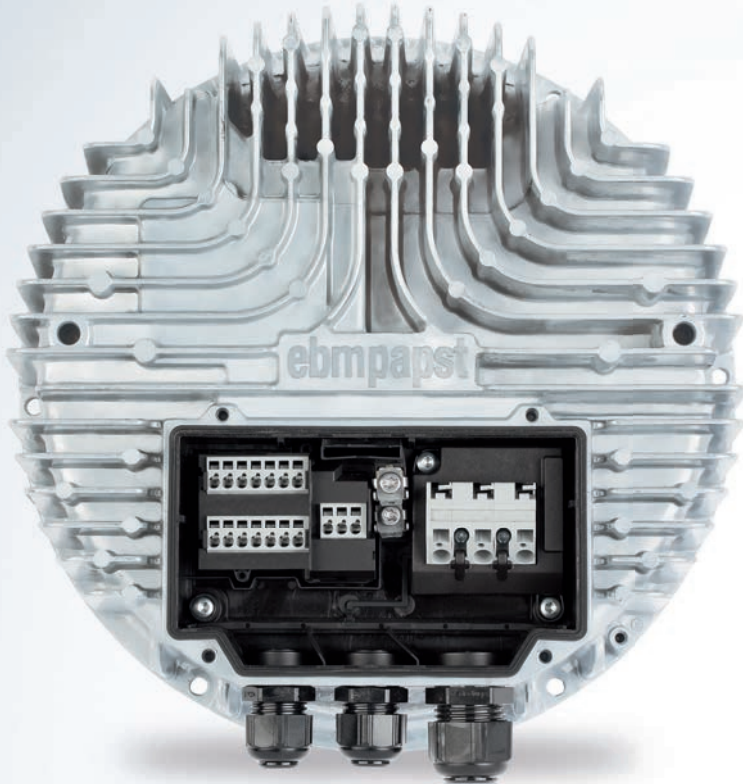

Technology

for EC centrifugal fans - RadiPac

ebmpapst

engineering a better life

	Page
Conection diagrams	166
Effects of installation space	170
Air flow measurement	171
Technical parameters & scope	172

Connection diagram: RP1) & RP2)

Connection diagram: RP1)

Technical features:

- Control input 0-10 VDC / PWM
- Output 10 VDC (+10 %) max. 10 mA
- Output 20 VDC (+/-20 %) max. 50 mA
- Output for slave 0-10 V max. 5 mA
- Input for sensor 0-10 V or 4-20 mA
- Operation and fault indicator
- Integrated PI controller
- Locked-rotor protection / Soft start / Motor current limitation
- RS 485 MODBUS-RTU / Alarm relay
- PFC, passive (standard) or PFC, active (see product-specific catalog page)
- Thermal overload protection for electronics/motor
- Undervoltage/phase failure detection
- Control interface with SELV potential safely disconnected from supply
- External enable input/External 24 V input (parameterization)



Connection diagram: RP2)

Technical features:

- Control input 0-10 VDC / PWM
- Output 10 VDC max. 10 mA
- RS 485 MODBUS-RTU / PFC, active
- Locked-rotor protection / Soft start
- Operation and fault indicator
- Power limiter
- Alarm relay
- Thermal overload protection for electronics/motor
- Motor current limitation
- Undervoltage detection
- Control interface with SELV potential safely disconnected from supply



Connection diagram: RP3) & RP4)

Connection diagram: RP3)

Technical features:

- Control input 0-10 VDC / PWM
- Output 10 VDC max. 10 mA
- RS 485 MODBUS-RTU / PFC, passive
- Locked-rotor protection / Soft start
- Operation and fault indicator
- Integrated PI controller
- Thermal overload protection for electronics/motor
- Motor current limitation / Alarm relay
- Undervoltage/phase failure detection
- Control interface with SELV potential safely disconnected from supply
- External 24 V input (parameterization)



Connection diagram: RP4)

Technical features:

- Configurable inputs/outputs (I/O)
- RFID - ISO 15693 compatible
- Operation and fault indicator with LED
- Integrated PI controller
- Locked-rotor protection
- Soft start / Alarm relay
- Motor current limitation
- Voltage output 3,3-24 VDC, Pmax = 800 mW
- RS 485 MODBUS-RTU / MODBUS V6
- Thermal overload protection for electronics/motor
- Undervoltage/phase failure detection
- Control interface with SELV potential safely disconnected from supply
- External 15-50 VDC input (parameterization)

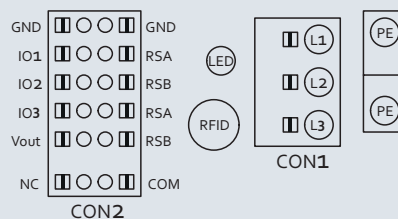

Connection diagram: RP5) & RP6)

Connection diagram: RP5)

Technical features:

- Control input 0-10 VDC / PWM
- Output 10 VDC max. 10 mA
- Output 20 VDC max. 50 mA
- Output for slave 0-10 V
- Operation and fault indicator
- Integrated PI controller
- Input for sensor 0-10 V or 4-20 mA
- Locked-rotor protection / Soft start
- RS 485 MODBUS-RTU / PFC, passive
- Thermal overload protection for electronics/motor
- Motor current limitation / Alarm relay
- Undervoltage/phase failure detection
- External enable input/External 24 V input (parameterization)

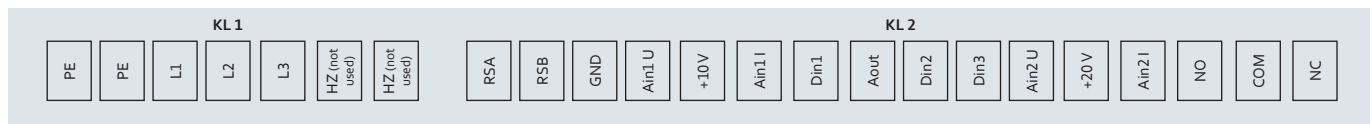

Connection diagram: RP6)

Technical features:

- Control input 0-10 VDC / PWM
- Output 10 VDC (+10 %) max. 10 mA
- Output 20 VDC (+/- 20 %) max. 50 mA
- Output for slave 0-10 V max. 5 mA
- Input for sensor 0-10 V or 4-20 mA
- Tach output
- Integrated PI controller
- Soft start / Motor current limitation
- RS 485 MODBUS-RTU / Alarm relay
- PFC, active / Power limiter
- Thermal overload protection for electronics/motor
- Undervoltage/phase failure detection
- Control interface with SELV potential safely disconnected from supply
- External enable input/External 24 V input (parameterization)

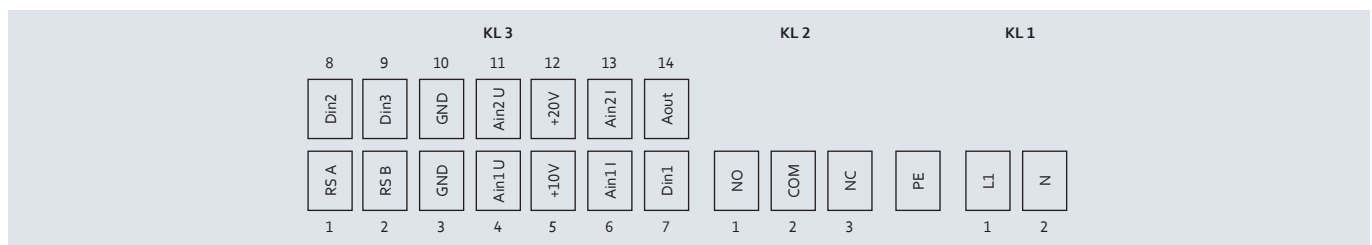

Connection diagram: RP7) & RP8)

Connection diagram: RP7)

Technical features:

- Control input 0-10 VDC / PWM
- Output 10 VDC (+10 %) max. 10 mA
- Alarm relay / Soft start
- Power limiter
- Motor current limitation
- Operation and fault indicator
- Integrated PI controller
- PFC, passive / Temperature derating
- RS 485 MODBUS-RTU
- EEPROM write cycles: 100.000 maximum
- Thermal overload protection for electronics/motor
- Undervoltage/phase failure detection
- Control interface with SELV potential safely disconnected from supply
- External 24 V input (parameterization)

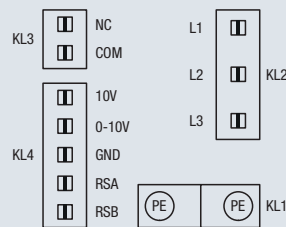

Connection diagram: RP8)

Technical features:

- Control input 0-10 VDC
- Output 10 VDC max. 10 mA
- Output for slave 0-10 V
- Motor current limitation
- Reverse polarity and locked-rotor protection
- Integrated PI controller
- Power limiter
- Soft start / PFC, passive
- RS 485 MODBUS-RTU / Alarm relay
- Thermal overload protection for electronics/motor
- Undervoltage/phase failure detection
- Control interface with SELV potential safely disconnected from supply
- External enable input/External 24 V input (parameterization)

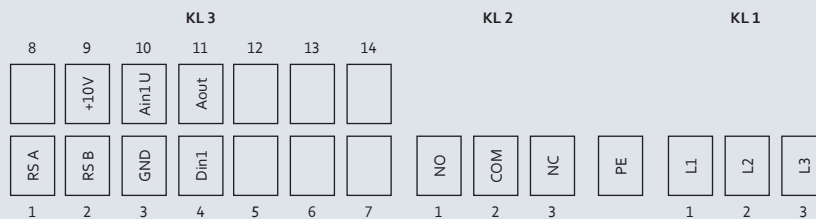

Effects of installation space

for EC centrifugal fans

Effects of installation space: Installation in a square box may cause a reduction of the air performance.

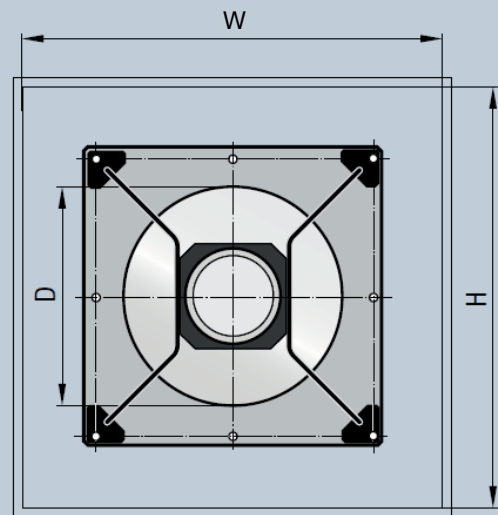
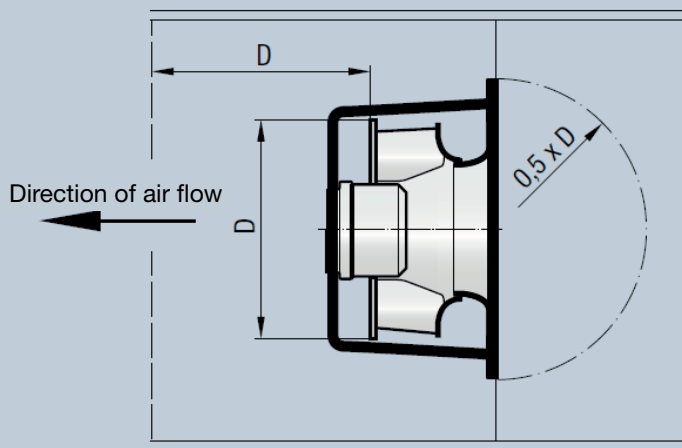

d_h = hydraulic diameter

W = Width of the box

Formula: $d_h = 2 \times W \times H / (W + H)$

H = Height of the box

D = Outside diameter of the fan

Correction values
for the air flow
Fan size 250 - 1000:

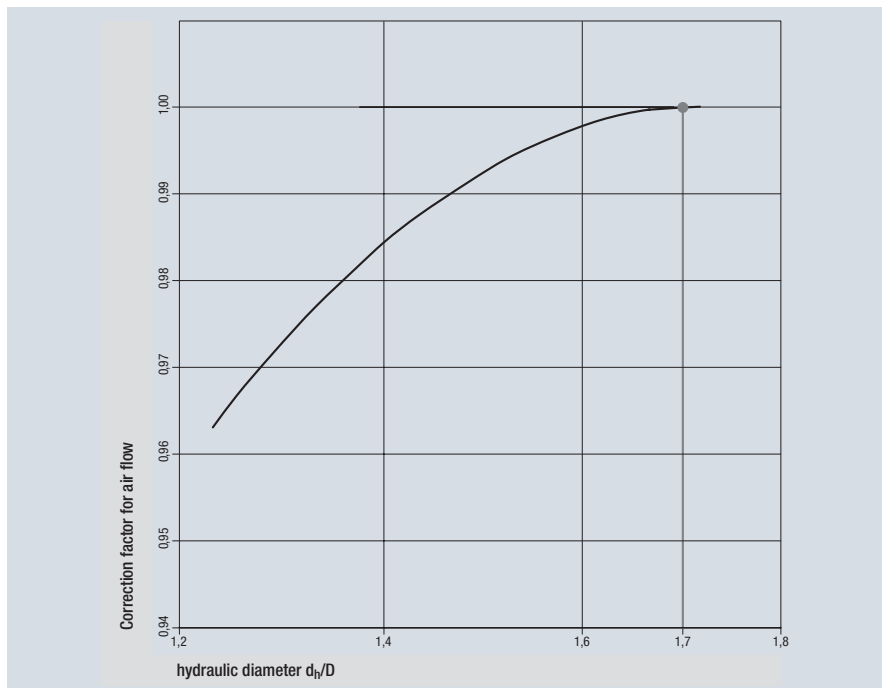

The correction values shown here were determined from an extensive series of measurements taken on our own internal chamber test rig. Here, square and rectangular outflow cross sections were considered. This is why the hydraulic diameter was used to determine the correction values.

The new RadiPac fans are known to be less vulnerable to tight installation situations. For square cross sections that are greater than 1.7 x the impeller diameter, no deduction has to be applied to the catalog curves.

Airflow determination

for EC centrifugal fans

Airflow determination:

The differential pressure method compares the static pressure upstream of the inlet ring with the static pressure in the inlet ring.

The airflow can be calculated from the differential pressure (between the static pressures) according to the following equation:

$$q_v = k \cdot \sqrt{\Delta p} \quad q_v \text{ in [m}^3/\text{h] und } \Delta p \text{ in [Pa]}$$

If the airflow is to be regulated to remain constant, the inlet pressure must be kept constant:

$$\Delta p = q_v^2 : k^2$$

k takes the specific properties of the inlet ring into account.

The pressure is tapped at 1 (4) point(s) on the circumference of the inlet ring.

The customer connection consists of a built-in T-shaped hose fitting.

The hose fitting is suitable for pneumatic hoses with an inside diameter of 4 mm.

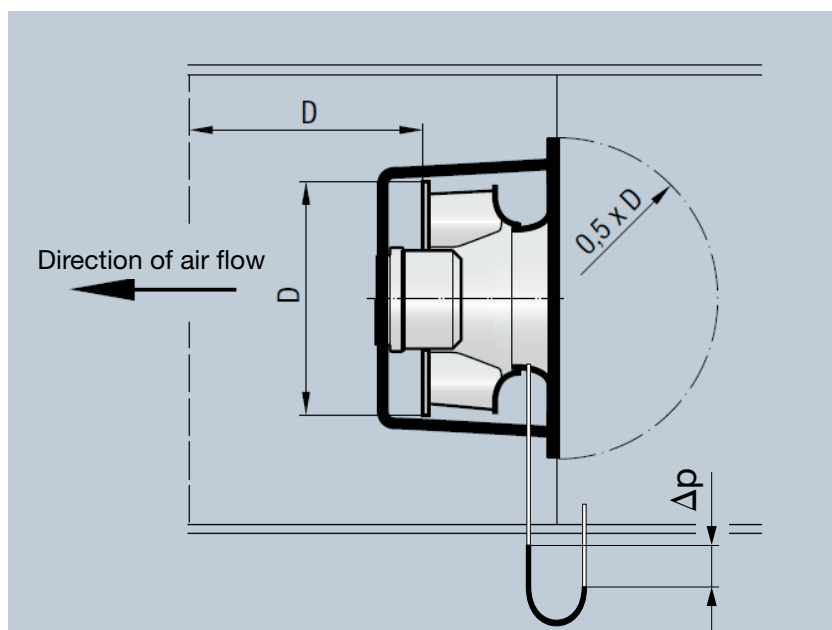

k-factors: (for RadiPac inlet rings)

Fan size	250	280	310	355	400	450	500
k-factor	76	77	116	148	188	240	281
Fan size	560	630	710	800	1000		
k-factor	348	438	545	695	1200		

Technical parameters & scope

High standards for all ebm-papst products

Here at ebm-papst, we constantly strive to further improve our products in order to be able to offer you the best possible product for your application. Careful monitoring of the market ensures that technical innovations are reflected in the improvements of our products. Based on the technical parameters listed below and the ambience you want our product to operate in, we here at ebm-papst can always work out the best solution for your specific application.

General performance parameters

Any deviations from the technical data and parameters described here are listed on the product-specific data sheet.

Degree of protection

The type of protection is specified in the product-specific data sheets.

Insulation class

The insulation class is specified in the product-specific data sheets.

Installation position

The mounting position is specified in the product-specific data sheets.

Condensate discharge holes

Information on the condensate discharge holes is provided in the product-specific data sheets.

Mode of operation

The mode of operation is specified in the product-specific data sheets.

Protection class

The protection class is specified in the product-specific data sheets.

Tightening torques for fan assembly

Please consult your ebm-papst contact for questions about which tightening torque to use.

Service life

The service life of ebm-papst products depends on two main factors:

- The service life of the insulation system
- The service life of the bearing system

The service life of the insulation system is essentially governed by the voltage level, the temperature and the ambient conditions such as humidity and condensation.

The service life of the bearing system is primarily governed by the thermal load on the bearings. For the majority of our products we use maintenance-free ball bearings which can be fitted in any installation position. Sleeve bearings can alternatively be employed, as described in the product-specific data sheets.

As a rough guide (depending on the general conditions), the ball bearings have a life expectancy L10 of approx. 40.000 hours of operation at an ambient temperature of 40 °C.

We will gladly provide you with a life expectancy calculation based on your specific usage conditions.

Motor protection/thermal protection

Information on motor protection and thermal protection is provided in the product-specific data sheets.

The following protection methods are provided depending on the type of motor and area of application:

- Thermal overload protector, in-circuit or external
- PTC with electronic diagnostics
- Impedance protection
- Thermal overload protector with electronic diagnostics
- Current limitation via electronics

If use is made of an external thermal overload protector, a commercially available tripping unit must be connected by the customer for shut-off. Motor protection conforming to the applicable standard must be fitted for products not provided with a built-in thermal overload protector and not protected against improper use.

Mechanical strain/performance parameters

All ebm-papst products are subjected to comprehensive testing in conformity with the normative specifications and also incorporating the extensive experience of ebm-papst.

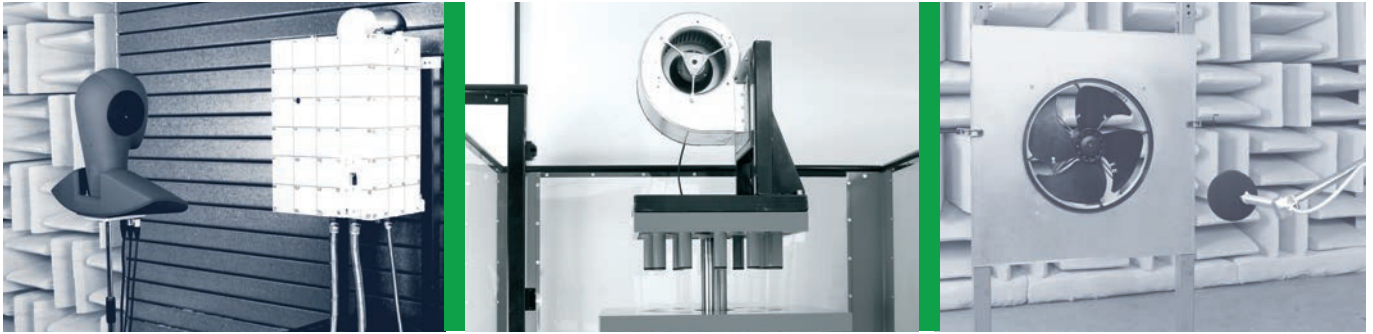

Vibration testing

Vibration testing is performed as follows:

- Vibration test in operation according to DIN IEC 68 Part 2-6
- Vibration test at standstill according to DIN IEC 68 Part 2-6

Shock load

Shock load testing is performed as follows:

- Shock load according to DIN IEC 68 Part 2-27

Balancing grade

Balancing grade testing is performed as follows:

- Residual imbalance according to DIN ISO 1940
- Standard balancing quality level G 6.3

Should your particular application require a higher level of balancing, please contact us and specify the details in your order.

Chemical and physical strain/performance parameters

Please consult your ebm-papst contact for any questions regarding chemical and physical strain.

Areas of use, industries & applications

Our products are used in a variety of industries and for numerous applications:

Ventilation, air conditioning and refrigeration technology, clean room technology, automotive and railway engineering, medical and laboratory technology, electronics, computer and office systems, telecommunications, household appliances, heating systems, machinery and installations, drive engineering. Our products are not intended for use in the aerospace or military industries!

Legal and normative specifications

The products described in this catalog are developed and manufactured in accordance with the standards applying to the particular product and, if known, in accordance with the conditions of the particular area of application.

Standards

Information on standards is provided in the product-specific data sheets.

EMC

Information on EMC standards is provided in the product-specific data sheets. Compliance with EMC standards has to be assessed on the final product, as EMC properties may change under different installation conditions.

Touch current

Information on touch current is provided in the product-specific data sheets. Measurement is performed according to IEC 60990.

Approvals

Please contact us if you require a specific type of approval (VDE, UL, GOST, CCC, CSA, etc.) for your ebm-papst product. Most of our products can be supplied with the applicable approval. Information on existing approvals is provided in the product-specific data sheets.

Air performance measurements

All air performance measurements are conducted on intake-side chamber test rigs conforming to the requirements of ISO 5801 and DIN 24163. The fans under test are attached to the measuring chamber with free air intake and exhaust (installation category A) and operated at nominal voltage, with alternating current also at nominal frequency, without any additional attachments such as a guard grill.

As required by the standards, the air performance curves shown are referenced to an air density of 1,15 kg/m³.

Technical parameters & scope

Air and sound measurement conditions

Measurements on ebm-papst products are taken under the following conditions:

- Axial and diagonal fans in airflow direction "V" in full nozzle without guard grill
- Backward-curved centrifugal fans, free-running with inlet ring
- Forward-curved single and dual-inlet centrifugal fans with housing
- Backward-curved dual-inlet centrifugal fans with housing

Sound measurements

All sound measurements are taken in anechoic rooms with reverberant floor. ebm-papst acoustic test chambers meet the requirements of accuracy class 1 as per DIN EN ISO 3745.

For sound measurement, the fans being tested are positioned in a reverberant wall and operated at nominal voltage, with alternating current also at nominal frequency, without any additional attachments such as a guard grill.

Sound pressure and sound power level

All acoustic values are determined in accordance with ISO 13347, DIN 45635 and ISO 3744/3745 as per accuracy class 2 and given in A-rated form.

For measurement of the sound pressure level L_p the microphone is located on the intake side of the fan being tested, generally at a distance of 1 m on the fan axis.

For measurement of the sound power level L_w 10 microphones are distributed over an enveloping surface on the intake side of the fan being tested (see graphic). The measured sound power level can be roughly calculated from the sound pressure level by adding 7 dB.

Measurement set-up according to ISO 13347-3 and DIN 45635-38:

- 10 measuring points

$$d \geq D$$

$$h = 1,5d \dots 4,5d$$

$$\text{Measurement area } S = 6d^2 + 7d(h + 1,5d)$$

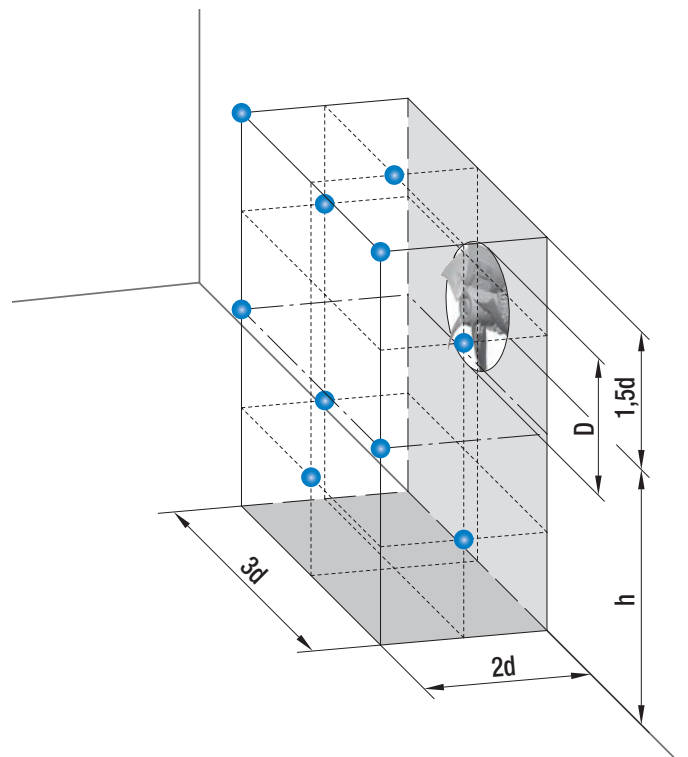

Cumulative level of several sound sources with the same level

The addition of 2 sound sources with the same level produces a level increase of approx. 3 dB.

The noise characteristics of several identical fans can be predicted on the basis of the sound values specified in the data sheet. This is shown in the adjacent graph.

Example: There are 8 axial fans A3G800 on a condenser. According to the data sheet, the sound pressure level of one fan is 75 dB(A). The level increase determined from the graph is 9 dB. This means that a total level of 84 dB(A) is to be expected for the installation.

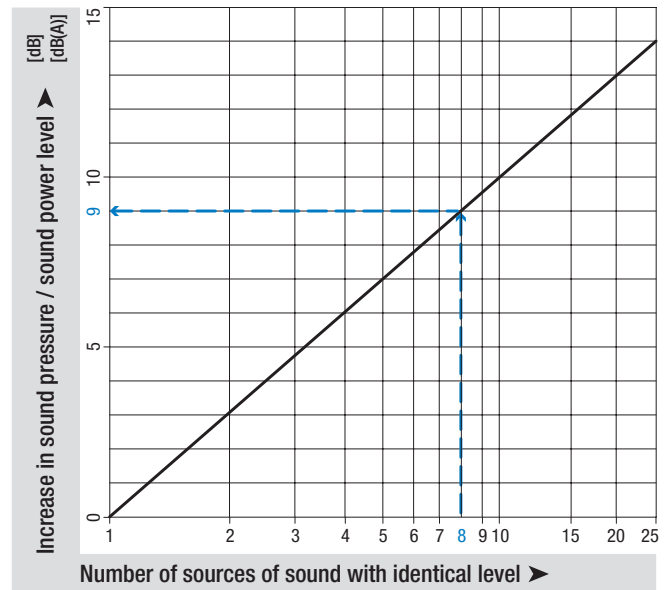

Cumulative level of two sound sources with different levels

The noise characteristics of two different fans can be predicted on the basis of the sound values specified in the data sheet. This is shown in the adjacent graph.

Example: In a ventilation unit, there is one axial fan A3G800 with a sound pressure level of 75 dB(A) at the point of operation and one axial fan A3G710 with 71 dB(A). The difference in level is 4 dB. The level increase of approx. 1.5 dB can now be read off the graph. This means that a total level of 76.5 dB(A) is to be expected for the unit.

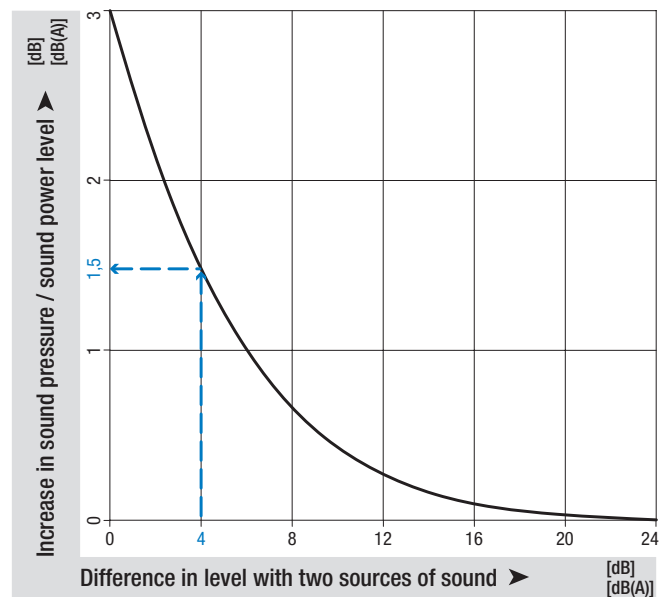

Distance laws

The sound power level is not governed by the distance from the noise source. By contrast, the sound pressure level decreases with increasing distance from the sound source. The adjacent graph shows the decrease in level under far field conditions. Far field conditions apply if there is a considerable distance between the microphone and the fan in relation to the fan diameter and the wavelength under consideration. On account of the complexity of the topic, literature should be consulted for more detailed information on far fields. The level in the far field decreases by 6 dB each time the distance is doubled. Different relationships apply in the near field of the fan and the level may decrease to a far lesser extent. The following example only applies to far field conditions and may vary considerably as a result of installation effects:

For an axial fan A3G300, a sound pressure level of 65 dB(A) was measured at a distance of 1 m. From the adjacent graph, this would yield a reduction of 26 dB at a distance of 20 m, i.e. a sound pressure level of 39 dB(A).

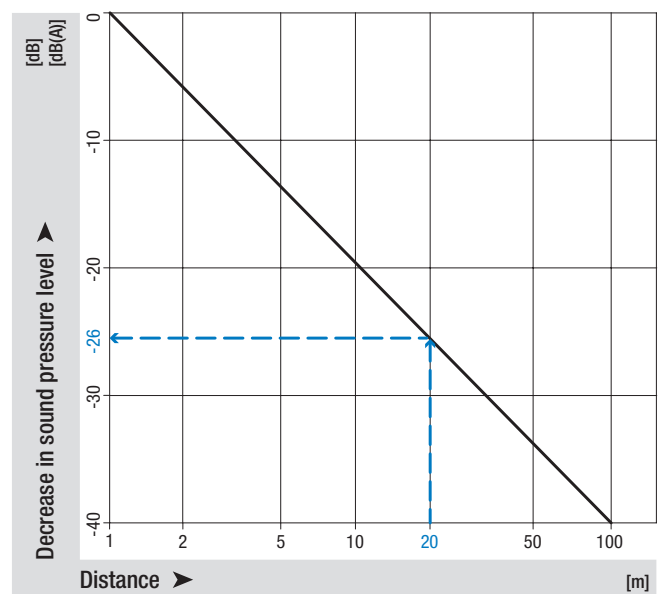

Technical parameters & scope

Aerodynamics fundamentals:

Further information can be found in our brochure "Technology - Basic principles"

Centrifugal fan operating range:

Middle section of the air performance curve:

- Maximum efficiency
- Minimum noise

To the left and right of the middle section of the air performance curve:

- Reduced efficiency
- Increasing noise

The fan's optimal range of use is highlighted in green in the adjoining performance curve.

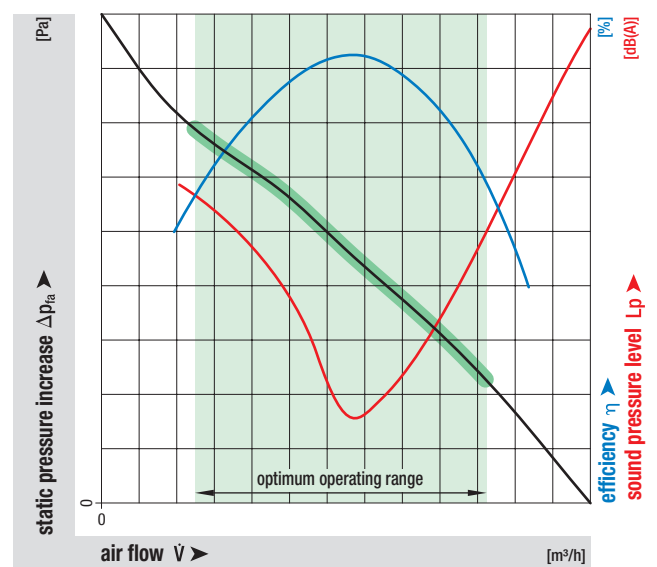

Influence of Speed n on the sound power level Lw:

The sound power level for changes in speed can be approximately determined based on the adjoining diagram and the following formula:

$$Lw_2 - Lw_1 = 50 \text{ dB} \cdot \log (n_2 : n_1)$$

Lw_1 = Sound power level after speed change

Lw_2 = Sound power level before speed change

n_1 = Changed speed

n_2 = Initial speed

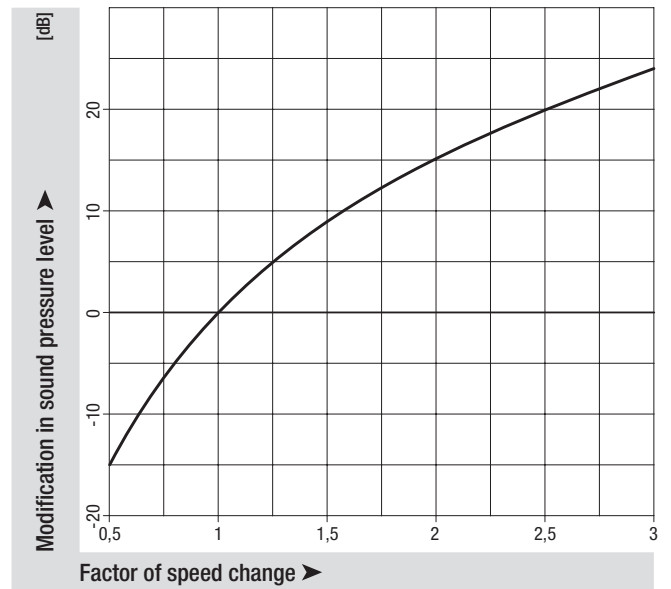



Always find the right *contact person!*

www.ebmpapst.com/contact

Contacts

Worldwide

ebmpapst

engineering a better life



Germany

ebm-papst Mulfingen GmbH & Co. KG

Bachmühle 2
74673 Mulfingen
GERMANY
Phone +49 7938 81-0
Fax +49 7938 81-110
info1@de.ebmpapst.com

ebm-papst St. Georgen GmbH & Co. KG

Hermann-Papst-Straße 1
78112 St. Georgen
GERMANY
Phone +49 7724 81-0
Fax +49 7724 81-1309
info2@de.ebmpapst.com

ebm-papst Landshut GmbH

Hofmark-Aich-Straße 25
84030 Landshut
GERMANY
Phone +49 871 707-0
Fax +49 871 707-465
info3@de.ebmpapst.com

ebmpapst

engineering a better life



ebm-papst
Mulfingen GmbH & Co. KG

Bachmühle 2
74673 Mulfingen
Germany
Phone +49 7938 81-0
Fax +49 7938 81-110
info1@de.ebmpapst.com