

# EC centrifugal fans RadiPac - C

Product Catalog 2022-10

**ebmpapst**

engineering a better life

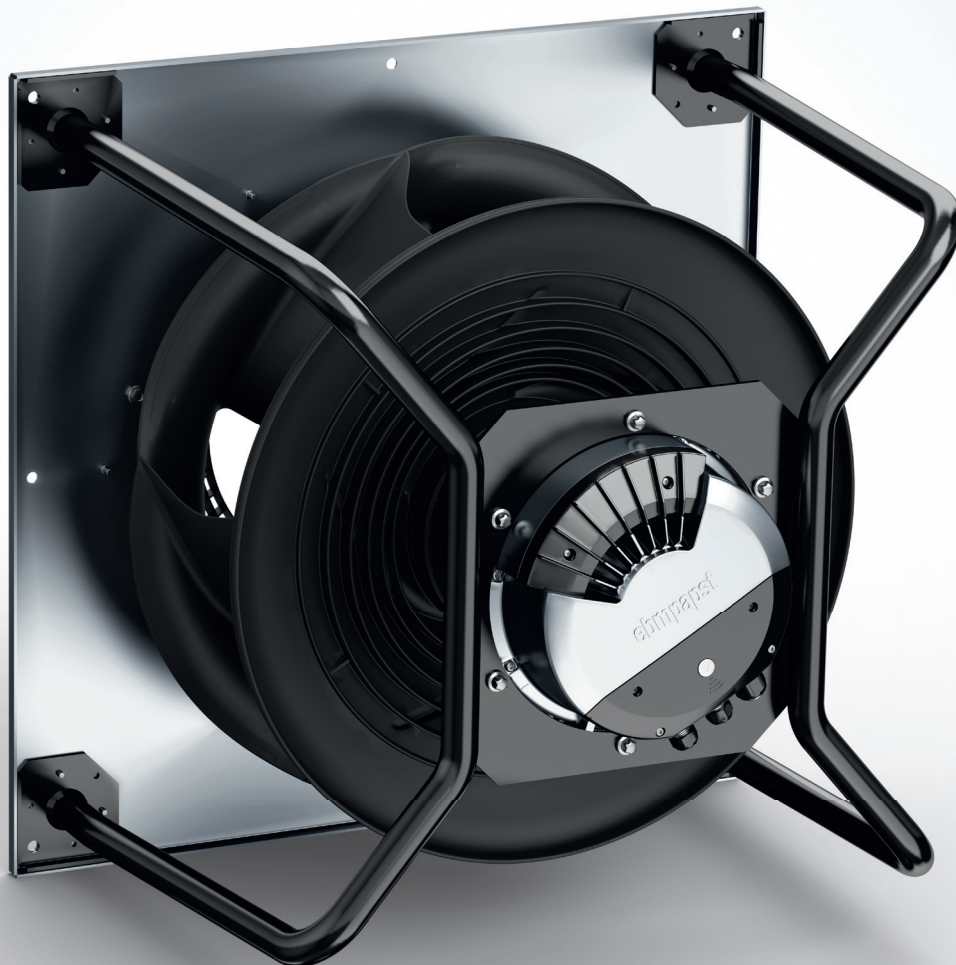



**ebmpapst**

engineering a better life

# Whichever way you turn it: *It's the benchmark*

The new RadiPac is turning ventilation technology on its head

Save the white paper now at:  
[www.ebmpapst.com/radipac](http://www.ebmpapst.com/radipac)



# The new *RadiPac - C*

	Page		Page
<b>Information</b>	<b>4</b>	About ebm-papst / GreenIntelligence	4
		More power, more efficiency / The new RadiPac	6
		Benchmark down to the last detail / Smasher of standard with standard dimensions / FanScout / Very reliable planning	
		Product & characteristics overview	16
<b>RadiPac - C 280 - 630</b>	<b>20</b>	EC centrifugal fans - RadiPac - C 280	24
		EC centrifugal fans - RadiPac - C 310	30
		EC centrifugal fans - RadiPac - C 355	38
		EC centrifugal fans - RadiPac - C 400	46
		EC centrifugal fans - RadiPac - C 450	54
		EC centrifugal fans - RadiPac - C 500	64
		EC centrifugal fans - RadiPac - C 560	74
		EC centrifugal fans - RadiPac - C 630	82
<b>Accessories</b>	<b>92</b>	FlowGrid air inlet grills	94
		Guard grills	95
		Inlet rings	96
<b>Technology</b>	<b>100</b>	Connection diagrams	102
		Effects of installation space	108
		Airflow determination	109
		Technical parameters & scope	110
<b>Contacts ebm-papst Worldwide</b>	<b>116</b>	<a href="http://www.ebmpapst.com/contact">www.ebmpapst.com/contact</a>	116

# About ebm-papst

As the leading supplier of ventilation and drive technology, ebm-papst is a highly respected engineering partner in many industries. With over 20.000 different products, we provide the right solution for just about any challenge.

As the logical next stage in the development of our high-efficiency GreenTech EC technology, we believe that sustainably oriented industrial digitization offers the greatest future prospects for our customers.

With GreenIntelligence, ebm-papst already offers intelligently interconnected complete solutions that are unrivaled worldwide and save energy costs and emissions.

## Six reasons why we are your ideal partner:

### Our systems expertise.

Of course you always want the best solution for every project. To get it, you need to consider the ventilation and drive engineering aspects as a whole.

And that is precisely what we do...with **motor technology** that sets standards, highly sophisticated **electronics** and **aerodynamically** optimized designs – all from a single source and perfectly matched.

These system solutions release unique synergies worldwide. What's more: they save you a lot of work. Using them means you can concentrate on your core business.

### ebm-papst's spirit of invention.

In addition to offering a wide range of products, we are able to develop customized solutions for you at any time. At our three German locations in Mulfingen, Landshut and St. Georgen, a diverse team of 600 engineers and technicians is ready to work to your specifications. Just get in touch with us to discuss your latest project.

### Our cutting-edge technology.

ebm-papst is not only a pioneer in developing highly efficient EC technology. We were also quick to recognize the potential of digitalization. This means we are now able to provide solutions that combine maximum energy efficiency with all the advantages of IoT and digital connectivity.

### Proximity to our customers.

ebm-papst has 29 worldwide production facilities, including those in Germany, China, the USA, plus 51 sales offices with an extensive network of sales representatives. You always have a local contact who speaks your language and is familiar with your market.

### Our quality standards.

Of course you can rely on the top quality of our products. After all, we employ an uncompromising quality management system at every stage of the process. This is documented by our certification in accordance with the DIN EN ISO 9001 and DIN EN ISO 14001 international standards, and the TS declaration of conformity.

### Sustainability as a way of life.

Assuming responsibility – for the environment, our employees and society – is an integral part of our corporate philosophy. That is why we develop products designed for maximum environmental compatibility and produce them using processes that preserve resources.

We support environmental awareness among our junior staff and are actively involved in sporting, cultural and educational activities.

All of which makes us a better partner.

# GreenIntelligence

## Making Engineers Happy



Why do our customers look so happy? Because when it comes to digitalization and sustainability, we provide them with a clear competitive edge with GreenIntelligence. The intelligent control and networking of fans and drives makes applications more powerful and efficient. Together with a long product life and highly efficient EC technology, we achieve lasting reductions in energy costs and emissions.

For **industrial ventilation technology**, solutions are in demand that ensure top performance and operational reliability in every situation. GreenIntelligence gives you robust fan solutions with intelligent networking capabilities that provide reliable performance data and extensive control and monitoring functions. They ensure high levels of efficiency and system availability while guaranteeing maximum data security.

With our **comprehensive range of services**, we accompany you and your projects through every step in the process, from your application's planning to its deployment. Make use of our experts' product expertise to offer your customers new and advanced features. Or use our digital tools for optimal product selection. That will make your processes more efficient and get your products to market faster.

Now you know why ebm-papst makes engineers happy.

### Here is how much Green-Intelligence there is in RadiPac:

- Monitoring of motor temperature
- Precise setting of air flow and operating points
- Automatic condition monitoring
- Fan as a sensor



Pablo verbessert die Performance seiner lufttechnischen Anlagen – sogar, wenn sie schon in Betrieb sind.



# More power, more efficiency, *more wow !*

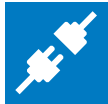

Sizes 280 to 630 as a motor-impeller combination or ready-to-install plug & play support bracket in standard or compact short version



Air flow up to 20.000 m<sup>3</sup>/h and pressures of more than 2.000 Pa



Noise level reduction of 3 to 7 dB(A) compared with the previous series depending on the operating point



GreenTech EC motors with nominal power from round 100 W to ca. 8 kW



Electronics with configurable control interface for analog and digital signals



GreenTech EC motors with efficiency equivalent to IE5 (IEC TS 60034-30-2:2016) and no rare earths

# Impossible ?

## *There's no such word !*

The requirements for ventilation and air conditioning devices are constantly increasing, especially when it comes to energy efficiency. This is due to increasingly strict legal requirements, but also to the growing environmental awareness of users and the possibility of saving energy costs, as rising energy prices are increasing cost pressure.

In AHUs, the fans are the largest power consumers. This potential for savings through more efficient technology is just as great.

But there are other requirements: The fans need to be as quiet as possible, because noise is also an unwanted emission. They should also cover a broad power spectrum in order to have more power reserves.

And, of course, IoT and intelligent data utilization are also playing an increasingly important role in ventilation technology. Despite this, the products should remain easy to use.

All of this poses major challenges for engineers. After all, any improvement in one area always means a compromise somewhere else. Can there be a fan that is impressive across the board?

**ebm-papst provides the answer with the new RadiPac:**

**Not only is it much more powerful than its predecessors, it is also especially energy-efficient, quiet, compact, and intelligent. Simply the benchmark, no matter how you spin it.**

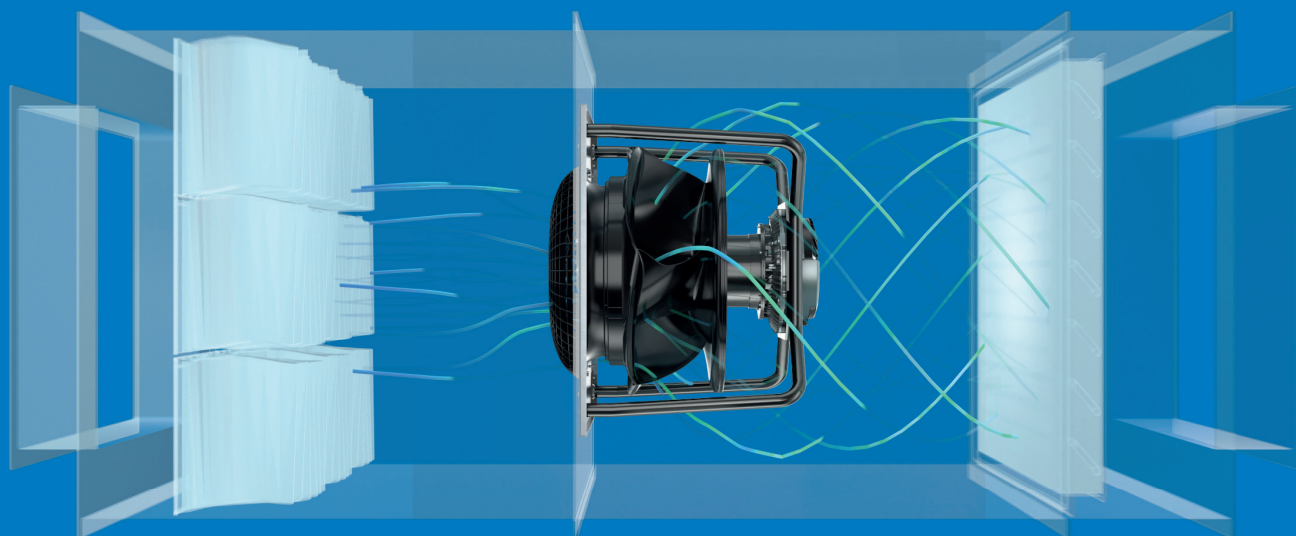

# The new RadiPac: *only the best for ventilation technology*

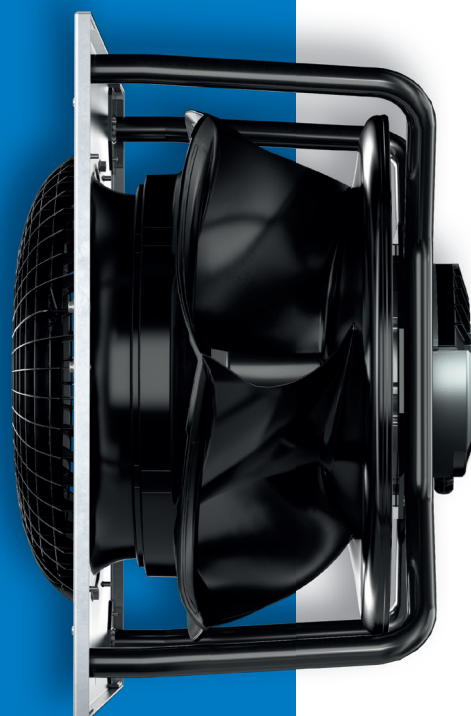



## More air with the *same* installaion space

thanks to an innovative  
impeller and new  
GreenTech EC motors.

ebm-papst has been consistently developing the RadiPac product range for many years, both in aerodynamics and in EC motor technology. This was the only way to achieve this latest generation's huge increase in performance – without increasing the installation space. Indeed the opposite is true: the new fans are even more compact.

### Reinventing the wheel again.

The newly developed impeller plays a major role in this increased efficiency. A high-strength, glass-fiber reinforced composite material was used, enabling the complex shape of the five spatially twisted and strength-optimized 3-D blades. Thanks to the rounded flow contour and the tapering profile of the blade outlet, flow losses have been drastically reduced and noise characteristics optimized. In addition, the wavy cover plate leads to an optimal air flow rate and thus remarkable air flows of up to 20.000 m<sup>3</sup>/h. The sturdy material also enables high speeds and hence pressures of more than 2.000 Pa – over the entire temperature range.

### The latest generation of EC motors.

The driving force behind the new RadiPac centrifugal fans are high-efficiency GreenTech EC motors in the power range to 8 kW. The integrated EC motors with a proven external rotor design achieve efficiency levels in accordance with the requirements for efficiency class IE5 set out in IEC/TS 60034-30-2. And yet they do not require any rare earths and are also impressively compact thanks to the typical ebm-papst external rotor design.

## More power but *not more* power *hungry.*

Technically, any increase in performance would have to come at the expense of power consumption. Not with the RadiPac: The combination of highly efficient EC motor technology, aerodynamic optimizations, innovative materials, and sophisticated design details ensure system efficiency levels of well over 70%. This means that equipment manufacturers will continue to meet the most stringent efficiency specifications and reduce energy costs for users.

## More flexible control *without the* *complications.*

AHUs are also getting smarter and smarter. Digital networking of the fans with their surroundings is a prerequisite for intelligent additional functions and flexible control options. The high-performance electronics provide everything required for this, such as a configurable control interface for analog and digital signals that can be individually adapted, as well as a serial MODBUS RTU interface. This enables operating data such as speed, power consumption or operating time to be read out and processed digitally, for example.

### Resonance detection: standard with the new RadiPac (4kW & 8kW).

A helpful and intelligent feature is included as standard for the first time with the new RadiPac: automatic resonance detection. The integrated vibration sensor measures mechanical vibrations and detects critical resonance points within the speed range. During initial commissioning, these vibrations are recorded and simply "run over" in normal operation later. This prevents premature bearing damage and thus system failures while increasing the fan's service life.

To prevent disruptive harmonics from occurring in the first place, ebm-papst has developed a solution in which the harmonic filter is already integrated: the 3-phase active PFC (power factor correction). This allows infrastructure components for energy and emergency power supply to be designed to be smaller, making them more cost-effective. The RadiPac with active PFC is available in sizes 500, 560 and 630 with or without a support bracket.

# Benchmark down to the last detail

## Impeller

- + **High static efficiency**
  - Innovative geometry reduces flow losses
  - Wavy cover plate for an optimal air flow rate
- + **Low noise emissions**
  - Optimum outflow characteristics
- + **Low vibration**
  - Dynamic balancing reduces bearing load
- + **Robust design**
  - Glass-fiber reinforced composite material
  - Permanently high circumferential speeds



## Inlet ring

- + **Pre-installed**
  - Optimized factory positioning of nozzle
  - Pressure tap for air flow control standard
- + **Low losses**
  - Optimized impeller inflow



## FlowGrid

- + **Reduced noise spectrum**
  - Low noise level
  - Dramatically dampened blade passing noise
  - Without loss of air performance and efficiency
- + **Compact design**
  - Small footprint
  - Fewer insulation measures
- + **Quick installation**
  - Through-holes for easy attachment
  - Customized attachments on request
- + **Robust design**
  - Resistant composite material
- + **Guard grill function**
  - Optionally as a closed version



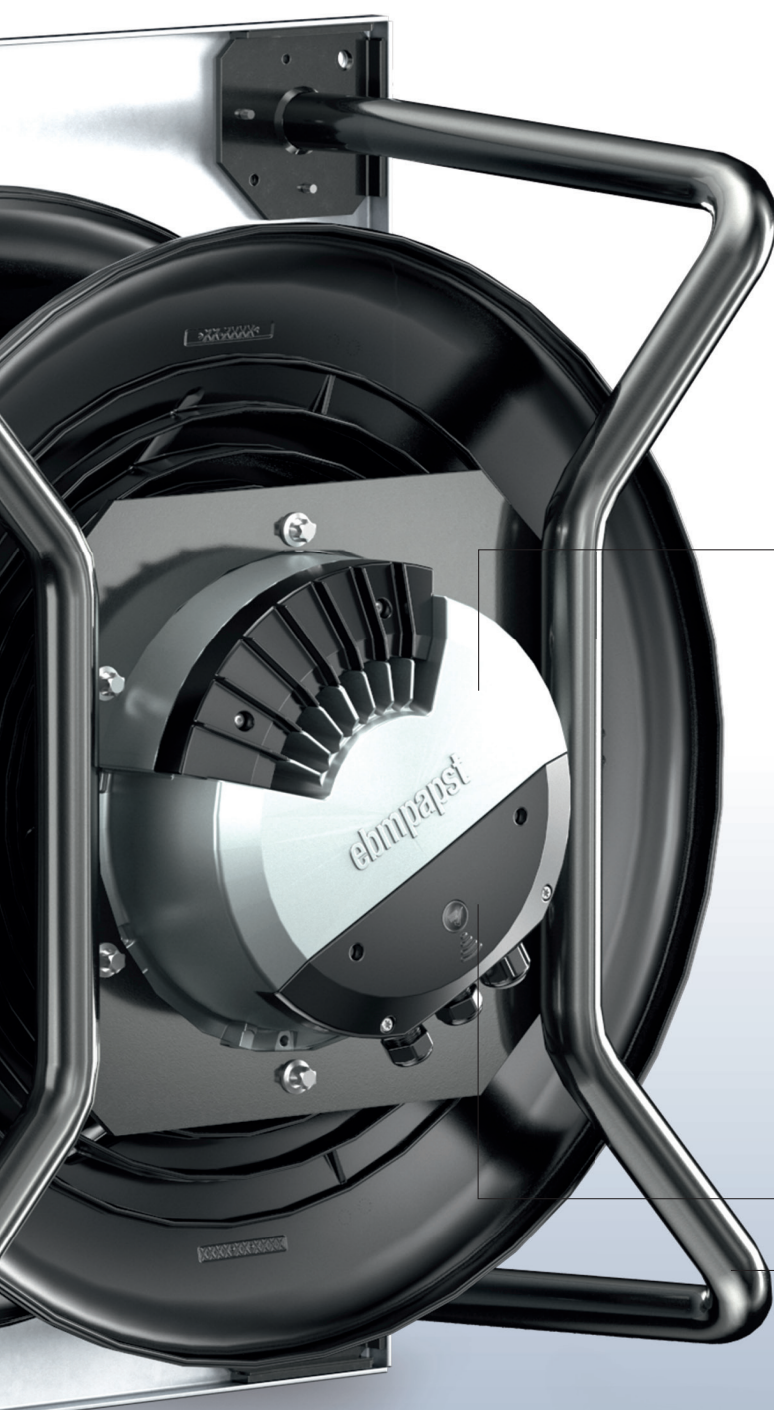

### GreenTech EC motor

- + Unbeatably compact**
  - Impeller directly on motor rotor
- + High efficiency**
  - Low copper and iron losses
  - Synchronous running prevents slip losses
  - No magnetic hysteresis losses
- + Economical operation**
  - Partial-load operation up to 1:10 at high efficiency
- + Long service life**
  - Maintenance-free bearings
  - Brushless commutation
- + Safe operation**
  - Insulated bearing system
- + Sustainable**
  - No rare earth magnets in rotor



### Electronics and connection area

- + Adaptable**
  - Configurable control interface
  - Control signal 0–10 VDC and MODBUS-RTU
  - Infinitely variable speed adjustment
  - Aktiv PFC (Power Factor Correction)
- + Universally deployable**
  - Suitable for use with 50 and 60 Hz networks
- + Increased operational reliability**
  - Integrated resonance detection
  - Integrated locked-rotor and thermal overload protection
  - Environment-resistant cable glands
- + Simple commissioning**
  - Central terminal area separated from electronics
  - No programming effort



### Support plate/support bracket

- + Robust sheet metal design**
  - Sendzimir galvanized sheet steel
- + Easy installation in AHU**
  - Complete, ready-to-install system
  - Compactness enables new design flexibility



# Smasher of standards with standard dimensions

The new RadiPac does a lot of things better. In order to suit every installation situation, the centrifugal fans come in a variety of designs – the choice is yours

## Short or standard ?

In the standard version, the motor is completely pulled out of the flow area. In the short version, the motor is immersed in the impeller. This makes the fans more compact, but still offers a significant increase in performance compared to previous models.



## With or without support bracket ?

Both RadiPac versions are available as a motor-impeller combination or as a ready-to-install plug & play solution in a compact support bracket for easy wall mounting. The support plates are dimensioned to make the best possible use of space on a Euro pallet. This saves transport costs and improves the CO<sub>2</sub> footprint.



## Simple fan replacement

Due to rising energy costs and increasingly important environmental considerations, it often pays to replace old fans, because the new RadiPac saves costs and resources in the long term. Thanks to its power density, retrofitting with the new RadiPac is possible without complex design changes.

# ebm-papst FanScout: click your way to the optimum RadiPac

Our radial fans can be configured individually for each application, and it is important to correctly consider all the relevant aspects when selecting your axial fan. When making your selection, you can rely on our experts' many years of experience, and on our professional fan selection software as well:

With its outstanding user-friendliness and real measured values, the ebm-papst FanScout has more than proven its worth already. It not only measures the performance of the individual fan components but also that of the fan as a complete system. The program allows you to quickly select the best fan for your application, to describe and modify the operating behavior and to document the technical specifications. Factors such as air performance, operating time and installation space can be taken into account in this process. TÜV SÜD has tested the difference between the actu-

al measurements and the data calculated using the software and assigned the accuracy of the calculation to the highest class.

### Exact presentation of the life cycle costs:

The costs of operation, acquisition, installation and service can be calculated for a defined period of time.

A practical advantage:

The software can be easily integrated into your device configuration program using the DLL interface.

### The best part:

ebm-papst pre-selects the products that are suitable for you. This saves you the trouble of searching through the broad product portfolio and helps you configure your application in advance.



## Would you like to find out more ?

All products from this catalog are combined in the FanScout collection "RadiPac-C\_2021\_12". This collection will be gladly provided to you upon request. Or do you have another question ? Then let us advise you personally:

Ralf Mühleck, Tel. +49 7938 81-7035, Ralf.Muehleck@de.ebmpapst.com  
or follow us at [www.ebmpapst.com/radipac](http://www.ebmpapst.com/radipac)

# Very reliable planning thanks to credible data

## Regular checks

To ensure that the measurements are always accurate and reproducible, test facilities and test equipment undergo regular checks. It is standard practice at ebm-papst for Quality Assurance to routinely monitor test equipment with measurement quantities traceable to national and international standards (German Calibration Service DKD, German National Metrology Institute PTB). The air flow is identified and regular leak testing is performed based on ISO 5801. Since the middle of 2014, calibration of the air flow measuring instruments and traceability to the national standard of the PTB have also formed part of the quality assurance process. The applicable range is from 100 m<sup>3</sup>/h to 40.000 m<sup>3</sup>/h with a reference measuring instrument accuracy of ±0,5 % of the measured value. Internal validation provides both assurance for the company and information for customers. The documentation is available for viewing at all times.

## Always find the right fan with the FanScout selection software:

If a fan is not powerful enough, there is an inadequate air flow rate. If it is too powerful, it has an unnecessary energy consumption. The ideal way to find exactly the right solution for specific requirements is to use reliable fan selection software like FanScout from ebm-papst.

The ebm-papst FanScout enables users to quickly select the best fan for the application concerned, to display and alter the operating characteristics and to record technical data. Factors such as air performance, operating time and installation space can be taken into account. The software contains valuable measurement data that help considerably in selecting just the right fan. The best part: ebm-papst pre-selects the products that are suitable for you. This saves you the trouble of searching through the extensive product portfolio and helps you configure your application in advance.

Physical quantity	Measuring range/unit	Measurement accuracy
Pressure increase $p_{sf}$	0 to 3.000 Pa	0,5% of measured value
Air flow $q_v$	100 to 100.000 m <sup>3</sup> /h	1 % of measured value
Air power $P_u$	kW	1,2% of measured value
Power consumption $P_e$	0 to 30 kW	0,5% of measured value
Torque M	0 to 200 Nm	1% of measured value
Overall efficiency e	%	1,3 percentage points
Speed N	0 to 99.999 min <sup>-1</sup>	1 min <sup>-1</sup>
Air density	approx. 1,2 kg/m <sup>3</sup>	0,1% of measured value
Sound power $L_{wA}$	from 30 dB(A)	1 dB(A)

Test stand design and tests in accordance with ISO 5801 – Industrial fans, performance measurement on standardized test stands DIN EN ISO 3744, DIN EN ISO 3745, ISO 13347-3 – Acoustics standards

*Measurement quantities and measurement accuracies attained with the aero-acoustic test stand.*

TÜV Süd has confirmed that the test stand satisfies all the requirements of DIN EN ISO 5801 in an air flow range from 500 m<sup>3</sup>/h to 39.000 m<sup>3</sup>/h and with a pressure increase of up to 1.000 Pa. The Fraunhofer Institute in Stuttgart approved the acoustic properties of the combination test stand. The institute confirmed the Class 1 rating for the ebm-papst noise measurement chamber.



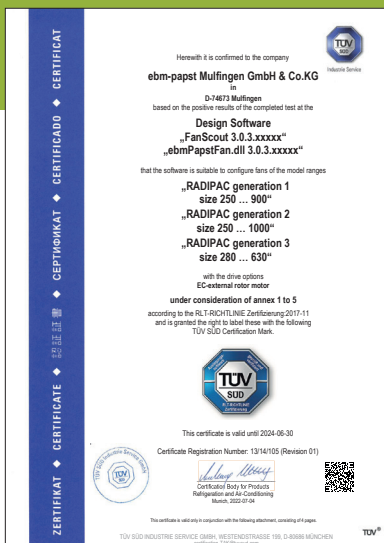

### Certified accuracy.

The inspection authorities (TÜV Süd) have confirmed the outstanding accuracy of the performance data supplied. Validation measurements on all catalog types in the RadiPac product range have shown that, on average, the efficiency level given by the FanScout tends to be lower rather than too high. How were the validation measurements conducted? 15 reference points were selected for each fan in the RadiPac product range and measurements were then taken on the certified chamber test rig. Comparison of the measured air performance data with the data from the FanScout revealed that the calculated values from the FanScout were almost identical to those measured under real conditions. According to the AHU directive 01, RadiPac fans therefore satisfy the requirements of the best possible accuracy class B0. This means that, in their as-delivered condition, ebm-papst RadiPac fans tend to have a higher efficiency level than that shown by the FanScout. This guarantees really reliable planning.

The RadiPac product range achieves the calculation accuracy B0. The classes are classified as shown in the following table:

Operating value	Limit deviation and classification		
	B0	B1	B2
Air flow	±1 %	±2,5 %	±5 %
Pressure increase	±1 %	±2,5 %	±5 %
Drive power	+2 %	+3 %	+8 %
Efficiency	-1 %	-2 %	-5 %

The calculation accuracy class determined by TÜV SÜD must be better than the delivery class specified by the manufacturer.

Otherwise, the delivery class – and the correction factor for  $P_m$  – must be graded.

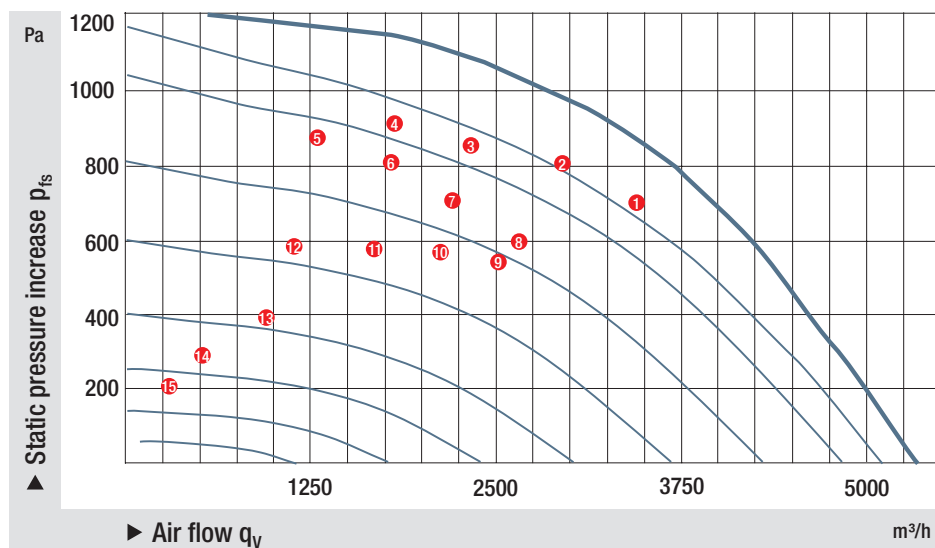

Validation test on a total of 38 different fan types from ebm-papst;  
 Example:  
 Map of a type from the FanScout (K3G310-AX69-01, Test\_Id. 159632, 159973)

①...⑮ Reference points:  
 Randomly selected operating points for measuring the actual power consumption



— Nominal speed  
 - - - Reduced speed

# Product overview

## EC centrifugal fans & modules

### RadiPac - C 280 - 450

Information

Size	Nominal voltage range VAC	Max. input power W	Version	Centrifugal fan 		Centrifugal module with support bracket 		on Page
				Type	Part number	Type	Part number	
280	1-200-277	60	Short	VBS0280CSLDS	8300100461	---	---	24
	1-200-277	85	Short	VBS0280CSLFS	8300100455	---	---	
	1-200-277	170	Short	VBS0280CSNES	8300100484	---	---	
	1-200-277	500	Short	VBS0280CSNGS	8300100483	VBH0280CSNGS	8300100482	
310	1-200-277	165	Short	VBS0310CSNES	8300100572	---	---	30
	1-200-277	500	Short	VBS0310CSNGS	8300100542	VBH0310CSNGS	8300100543	
	3-380-480	1500	Short	VBS0310CTPMS	8300100039	VBH0310CTPMS	8300100044	
	3-380-480	1500	Long	VBS0310CTPMS	8300100046	VBH0310CTPMS	8300100053	
	3-380-480	2750	Long	VBS0310CTRLS	8300100103	VBH0310CTRLS	8300100104	
355	1-200-277	165	Short	VBS0355CSNES	8300100537	---	---	38
	1-200-277	430	Short	VBS0355CSNGS	8300100538	VBH0355CSNGS	8300100540	
	3-380-480	1500	Short	VBS0355CTPMS	8300100050	VBH0355CTPMS	8300100054	
	3-380-480	1500	Long	VBS0355CTPMS	8300100040	VBH0355CTPMS	8300100049	
	3-380-480	2750	Long	VBS0355CTRLS	8300100086	VBH0355CTRLS	8300100087	
400	3-380-480	1400	Short	VBS0400CTPMS	8300100465	VBH0400CTPMS	8300100466	46
	3-380-480	1300	Long	VBS0400CTRHS	8300100480	VBH0400CTRHS	8300100479	
	3-380-480	1500	Short	VBS0400CTRHS	8300100055	VBH0400CTRHS	8300100056	
	3-380-480	3740	Short	VBS0400CTRNS	8300100077	VBH0400CTRNS	8300100078	
	3-380-480	3600	Long	VBS0400CTRNS	8300100059	VBH0400CTRNS	8300100058	
	3-380-480	4500	Long	VBS0400CTTLS	8300100127	VBH0400CTTLS	8300100128	
450	1-200-277	500	Short	VBS0450CSPKS	8300100444	VBH0450CSPKS	8300100445	54
	3-380-480	1070	Short	VBS0450CTPMS	8300100405	VBH0450CTPMS	8300100406	
	3-380-480	1430	Short	VBS0450CTRLS	8300100549	VBH0450CTRLS	8300100550	
	3-380-480	1300	Long	VBS0450CTRLS	8300100503	VBH0450CTRLS	8300100502	
	3-380-480	3850	Short	VBS0450CTRNS	8300100312	VBH0450CTRNS	8300100311	
	3-380-480	3050	Long	VBS0450CTRNS	8300100345	VBH0450CTRNS	8300100344	
	3-380-480	4050	Long	VBS0450CTTLS	8300100038	VBH0450CTTLS	8300100043	
	3-380-480	6300	Long	VBS0450CTTPS	8300100076	VBH0450CTTPS	8300100075	



Technische Änderungen vorbehalten. FanScout Kollektion "RadiPac-C\_2022\_10"



# Product overview

## EC centrifugal fans & modules

### RadiPac - C 500 - 630

Size	Nominal voltage range VAC	Max. input power W	Version	Centrifugal fan 		Centrifugal module with support bracket 		on Page
				Type	Part number	Type	Part number	
500	1-200-277	500	Short	VBS0500CSPMS	8300100259	VBH0500CSPMS	8300100260	64
	3-380-480	1430	Short	VBS0500CTRLS	8300100494	VBH0500CTRLS	8300100498	
	3-380-480	1380	Long	VBS0500CTRLS	8300100528	VBH0500CTRLS	8300100529	
	3-380-480	3000	Short	VBS0500CTRNS	8300100266	VBH0500CTRNS	8300100265	
	3-380-480	2500	Long	VBS0500CTRNS	8300100318	VBH0500CTRNS	8300100319	
	3-380-480	4000	Long	VBS0500CTTLS	8300100534	VBH0500CTTLS	8300100547	
	3-380-480	4150	Long	VBS0500CTTLS	8300100083	VBH0500CTTLS	8300100082	
	3-380-480	6210	Long	VBS0500CTTRS	8300100069	VBH0500CTTRS	8300100068	
560	3-380-480	1270	Short	VBS0560CTRNS	8300100520	VBH0560CTRNS	8300100521	74
	3-380-480	4000	Long	VBS0560CTTPS	8300100535	VBH0560CTTPS	8300100546	
	3-380-480	4250	Short	VBS0560CTTPS	8300100041	VBH0560CTTPS	8300100047	
	3-380-480	4400	Long	VBS0560CTTPS	8300100096	VBH0560CTTPS	8300100095	
	3-380-480	6500	Short	VBS0560CTTRS	8300100222	VBH0560CTTRS	8300100221	
	3-380-480	6500	Long	VBS0560CTTRS	8300100102	VBH0560CTTRS	8300100101	
630	3-380-480	1070	Short	VBS0630CTRNS	8300100446	VBH0630CTRNS	8300100447	82
	3-380-480	3150	Short	VBS0630CTTLS	8300100092	VBH0630CTTLS	8300100091	
	3-380-480	3900	Short	VBS0630CTTPS	8300100060	VBH0630CTTPS	8300100057	
	3-380-480	3720	Long	VBS0630CTTPS	8300100093	VBH0630CTTPS	8300100094	
	3-380-480	4000	Long	VBS0630CTTPS	8300100544	VBH0630CTTPS	8300100545	
	3-380-480	5850	Long	VBS0630CTTRS	8300100045	VBH0630CTTRS	8300100048	
	3-380-480	6400	Short	VBS0630CTTRS	8300100218	VBH0630CTTRS	8300100217	

Technische Änderungen vorbehalten. FanScout Kollektion "RadiPac-C\_2022\_10"

# Characteristics overview

## EC centrifugal fans & modules

### RadiPac - C 280 - 630

## Power brought to the operating point

The data shown is based on real performance measurements carried out on state-of-the-art chamber test rigs. The entire fan unit, consisting of motor, control electronics, and impeller, is measured at varying load states. This ensures that we obtain reliable data, and that you can count on these values being reached when selecting a fan.

So, there will be no nasty surprises when the fans are started up.

The measured data forms the basis for the FanScout design program, which is available on request. This software can be used to calculate what operating costs are to be expected or to perform lifecycle cost analyses.

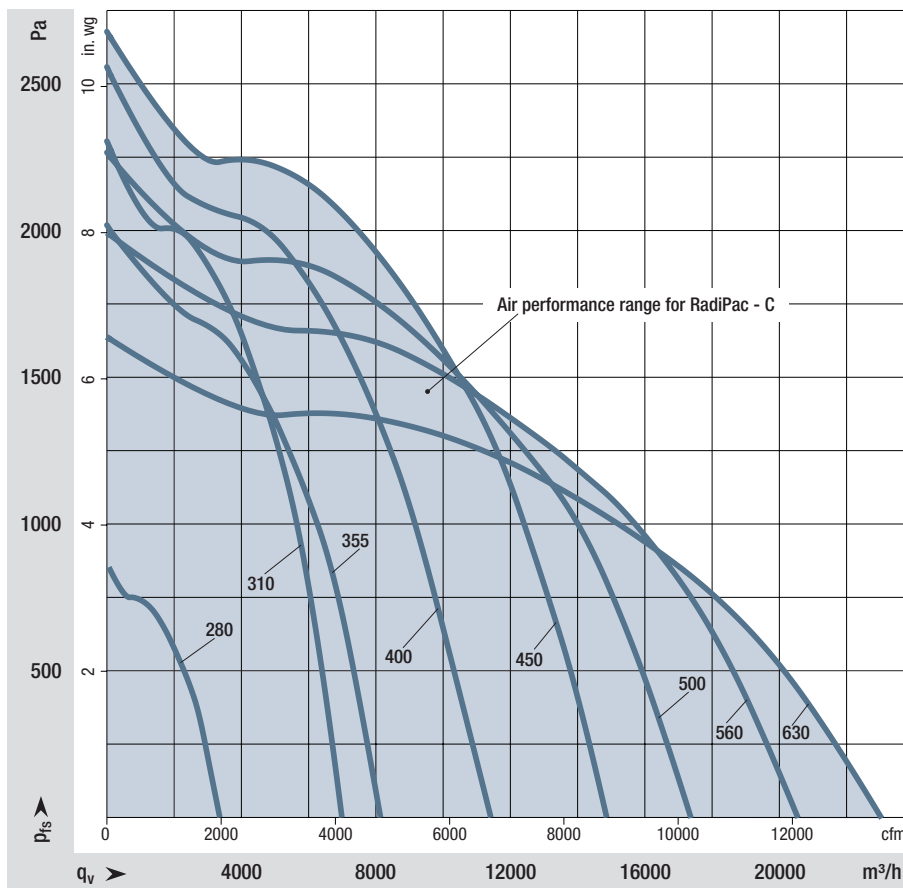

Max. air performance range of the RadiPac - C series. Max. air performance curves of sizes 280 - 630.



*ebm-papst*

# EC centrifugal fans & modules



**ebmpapst**

engineering a better life

# RadiPac - C 280 - 630

	Page
Tender specification	22
280	24
310	30
355	38
400	46
450	54
500	64
560	74
630	82

# Tender specification

## EC centrifugal fans & modules - RadiPac - C

### Fan size 280 to 630

**Direct-drive, single inlet centrifugal fans with backwards-curved high-performance centrifugal impellers made of composite material, based on a GreenTech EC external rotor motor with integrated control electronics.**

One-piece impeller made of high-strength, glass-fiber reinforced composite material. 5 backward-curved and twisted 3D blades optimized in terms of strength. Blade inlet with rounded flow contour and profile tapered toward the rear to the blade outlet. Corrugated cover plate for optimum filling level. Flow-optimized inlet ring made of composite material with pressure test nipple.

Motor-impeller in accordance with DIN ISO 21940, statically and dynamically balanced on two planes to balancing grade G 6.3. GreenTech EC external rotor motors achieve or exceed the efficiency specifications in accordance with efficiency class IE5 (IEC TS 60034-30-2:2016), magnets without the use of rare earths, maintenance-free ball bearings with long-term lubrication, theoretical nominal service life of at least 40.000 operating hours.

Soft start, integrated current limitation, automatic resonance detection (from an input power of 2kW), extended voltage input 1~200-277 V, 50/60 or 3~380-480 V, 50/60 Hz. The fan can be used with all standard power supply networks with unaltered air performance. Integrated control electronics, low-noise commutation logic; 100% speed control; all fans have an RS485/MODBUS RTU interface, no shielded cables are required for the power supply. All 1~ types feature integrated active PFC (Power Factor Correction) to reduce disturbing harmonic content. Terminal box made of aluminum/plastic with easily accessible connection area, environment-resistant cable glands.

#### **Version for wall mounting:**

Ready-to-install support bracket intended for wall mounting. Support structure made of bent round steel, or steel pipe welded and coated in black. Mounting plate made of sendzimir galvanized sheet steel. Inlet ring made of composite material with pressure test nipple. Installation position with horizontal motor shaft and vertical motor shaft with rotor on bottom. Vertical installation position with rotor on top on request.

Any work required for isolation from structure-borne noise is to be performed by the customer. The fan satisfies the applicable EMC guidelines and requirements with regard to harmonic effects (see applicable data sheet for specific figures).

Documentation and marking in accordance with the applicable EU directives.

Reliable performance data, air performance measurements taken on an intake-side chamber test rig in accordance with ISO 5801 and DIN 24163. Noise measurements taken in an anechoic room in accordance with DIN EN ISO 3745.

#### **Integrated protective devices:**

- Alarm relay with floating contacts (250 V AC/2 A,  $\cos \varphi = 1$ )
- Locked-rotor protection
- Phase failure detection
- Soft start of motors
- Line undervoltage detection
- Thermal overload protection for electronics and motor
- Short circuit protection

#### **Optional:**

- **Other and specific requirements on request**
- **FlowGrid air inlet grill:** FlowGrid air inlet grill tailor-made for the fan, to reduce assembly and system-related noise. FlowGrid made of high-grade composite material in one piece, available ready for installation and also suitable for retrofitting. Ideal solution for confined intake conditions at the fan and/or if upstream turbulence-inducing fittings are unavoidable. The FlowGrid breaks up the turbulence fields and straightens the flow, resulting in distinct noise reduction.

# Tender specification

EC centrifugal fans & modules - RadiPac - C

Fan size 280 to 630

## Technical data:

Fan type	= _____
Part number	= _____
Air flow	qV = _____ m <sup>3</sup> /h, cfm
Stat. pressure increase	pfs = _____ Pa, in wg
Stat. overall efficiency	$\eta_{esd}$ = _____ %
Operating speed	n = _____ min <sup>-1</sup>
Motor type	= EC motor
Speed change	= 0-100 % speed control
Motor efficiency class	= IE5
Total power input	Ped = _____ kW
Specific fan power	SFP = _____ kW/(m <sup>3</sup> /s)
Nominal voltage range	U <sub>N</sub> = _____ V
Line frequency	f = 50 / 60 Hz
Nominal current	I <sub>N</sub> = _____ A
Degree of protection	= IP55
Sound power level	L <sub>WA</sub> (A, in) = _____ / L <sub>WA</sub> (A, out) = _____ dB(A)
Sound pressure level (at 1 m)	L <sub>pA</sub> (A, in) = _____ / L <sub>pA</sub> (A, out) = _____ dB(A)
Perm. ambient temperature	T = _____ to _____ °C
Weight of fan	m = _____ kg



EC centrifugal fans RadiPac Motor-impeller



EC centrifugal fans RadiPac Support bracket with FlowGrid

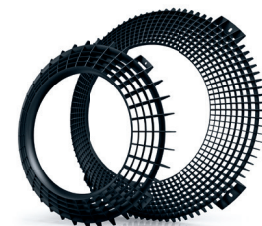

Optionally FlowGrid Air inlet grill



EC centrifugal fans RadiPac Motor-Impeller short version



EC centrifugal fans RadiPac Support bracket short version with FlowGrid

Refer to data sheet for dimensions and wiring.

# RadiPac 280

EC centrifugal fans, backward curved



## Material/Surface

- Support bracket: Steel, painted black
- Support plate: Sheet steel, galvanized
- Inlet nozzle: ABS plastic
- Impeller: PP plastic
- Rotor: Thick-film passivated
- Electronics housing: Die-cast aluminum

## Mechanical characteristics

- Number of blades: 5
- Drehrichtung (epM): Clockwise, viewed toward rotor
- Installation position: Any, Shaft horizontal or rotor on bottom; rotor on top on request, See legend on product drawing
- Condensation drainage holes: None, open rotor, On rotor side
- Mode: S1
- Motor bearing: Ball bearing

## Additional Information

- Information about touch current, electrical connection, degree of protection, insulation class, environmental protection class, EMC standards as well as standards and approvals can be found in the product-specific data sheets.

from page 26	Drawings
from page 92	Accessories
from page 102	Connection diagrams and technical equipment
from page 110	Environment and general conditions
More at	<a href="http://www.ebmpapst.com/worldwide">www.ebmpapst.com/worldwide</a> <a href="http://www.ebmpapst.com/">www.ebmpapst.com/</a>

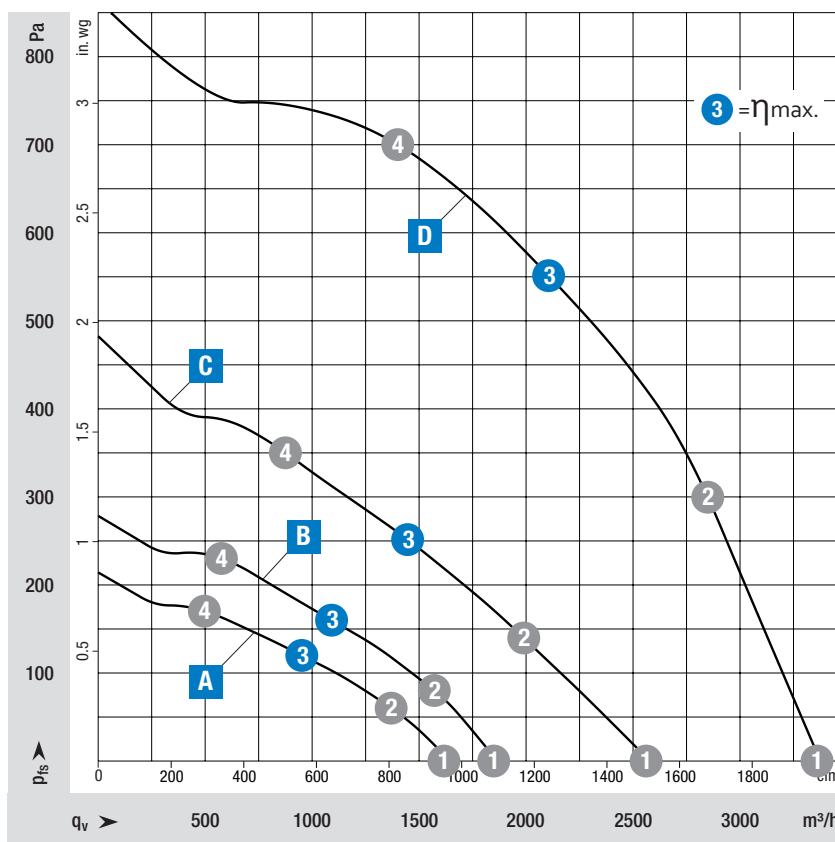

### Measuring conditions





Air performance measured after: ISO 5801, installation category A, with ebm-papst inlet nozzle without contact protection.

Suction-side noise level: LwA according to ISO 13347, LpA measured at a distance of 1 m on the fan axis.

The specifications apply only under the specified measuring conditions and may change due to installation conditions.

In case of deviations from the standard design, the characteristic values must be checked in the installed condition!



Nominal voltage range 1- 200-240 VAC, 50/60 Hz				Characteristic Curve	Operating point	Nominal voltage	Speed n	Max. Input power P <sub>ed</sub>	Max. Input current I	Sound power level L <sub>WA</sub>	Max. back pressure	Perm. ambient temp.	Protection class	Connection diagrams and technical equipment	
Type	Part number	Fan type			V	rpm	W	A	dB(A)	Pa	°C				
VBS0280CSLDS	8300100461	Centrifugal fan		Short-version	A	1	230	1,560	49	0.43	65	---	-25...+40	IP54	Page 107
						2	230	1,500	59	0.50	60				
						3	230	1,450	60	0.50	55				
						4	230	1,505	58	0.50	56				
VBS0280CSLFS	8300100455	Centrifugal fan		Short-version	B	1	230	1,750	72	0.60	68	---	-25...+40	IP54	Page 107
						2	230	1,730	85	0.70	63				
						3	230	1,675	85	0.70	58				
						4	230	1,740	85	0.70	60				
VBS0280CSNES	8300100484	Centrifugal fan		Short-version	C	1	230	2,400	170	1.40	75	---	-25...+40	IP54	Page 106
						2	230	2,170	170	1.40	67				
						3	230	2,100	170	1.40	63				
						4	230	2,160	170	1.40	67				
Nominal voltage range 1- 200-277 VAC, 50/60 Hz					V	rpm	W	A	dB(A)	Pa	°C				
Type	Part number	Fan type													
VBS0280CSNGS	8300100483	Centrifugal fan		Short-version	D	1	230	3,130	349	1.54	81	---	-25...+40	IP54	Page 105
						2	230	3,130	464	2.03	74				
						3	230	3,130	500	2.20	69				
						4	230	3,130	482	2.11	73				
VBH0280CSNGS	8300100482	Support bracket		Short-version											

Subject to changes.

Values set in blue are nominal data at the operating point at maximum load.

# RadiPac 280

**A** VBS0280CSLDS 8300100461 EC centrifugal fan - RadiPac

Dimensions in mm

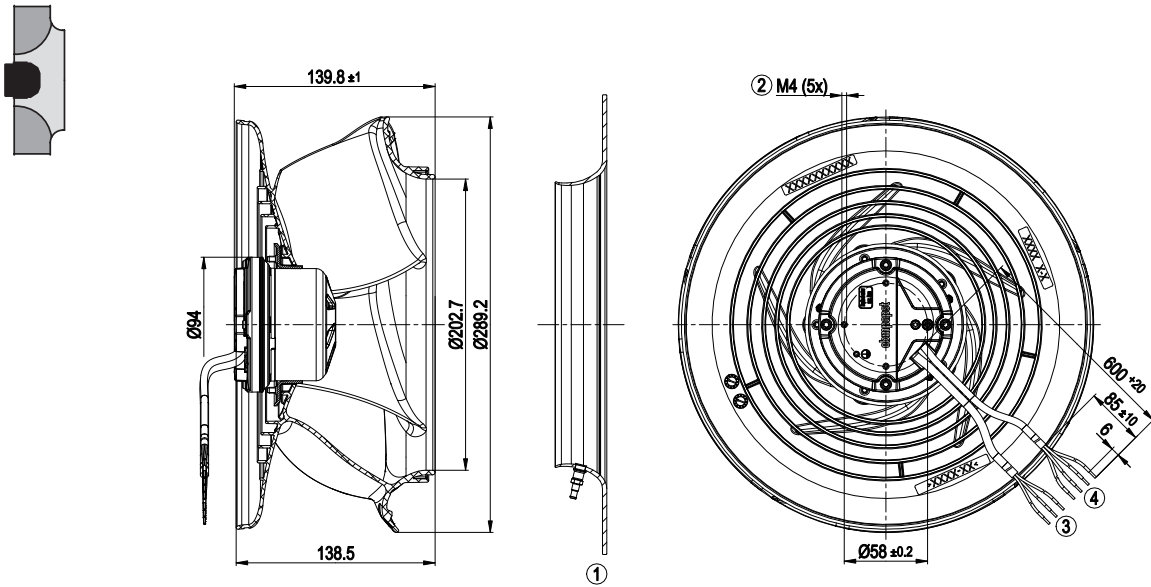

- ① Accessory part: Inlet ring 8217104581 with pressure tap (k-factor: 98) (not included in scope of delivery)
- ② Max. clearance for screw 5 mm
- ③ Supply line (PWR) PVC AWG20, 3x splice
- ④ Control wire (CTRL) PVC AWG22

Pin assignment: See connection diagram  
Mounting position: Any

**B** VBS0280CSLFS 8300100455 EC centrifugal fan - RadiPac

Dimensions in mm

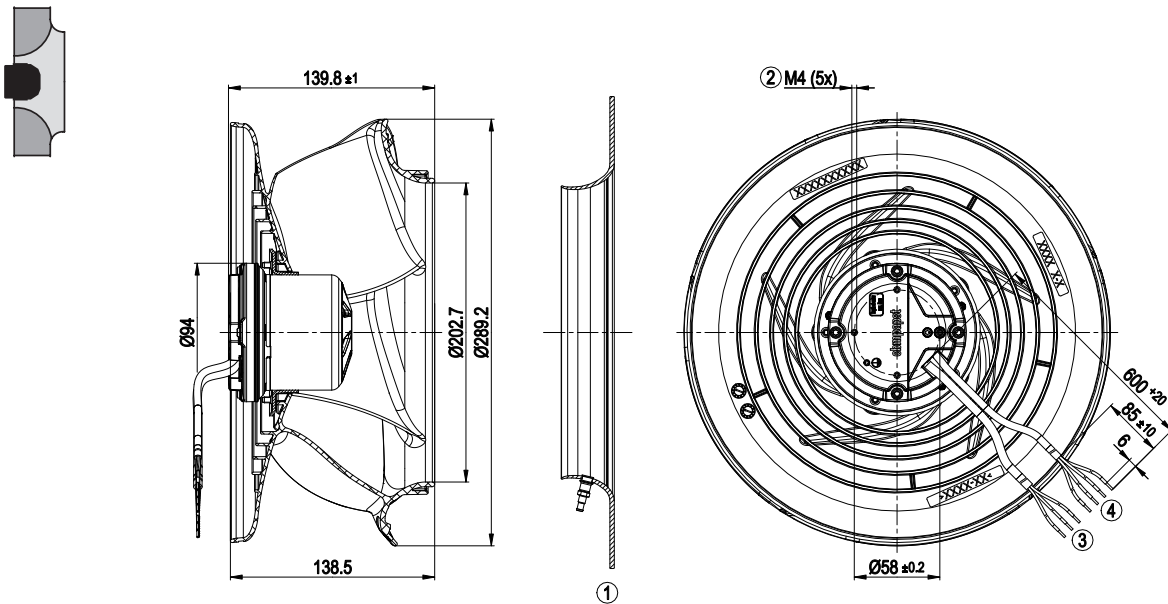

- ① Accessory part: Inlet ring 8217104581 with pressure tap (k-factor: 98) (not included in scope of delivery)
- ② Max. clearance for screw 5 mm
- ③ Supply line (PWR) PVC AWG20, 3x splice
- ④ Control wire (CTRL) PVC AWG22

Pin assignment: See connection diagram  
Mounting position: Any

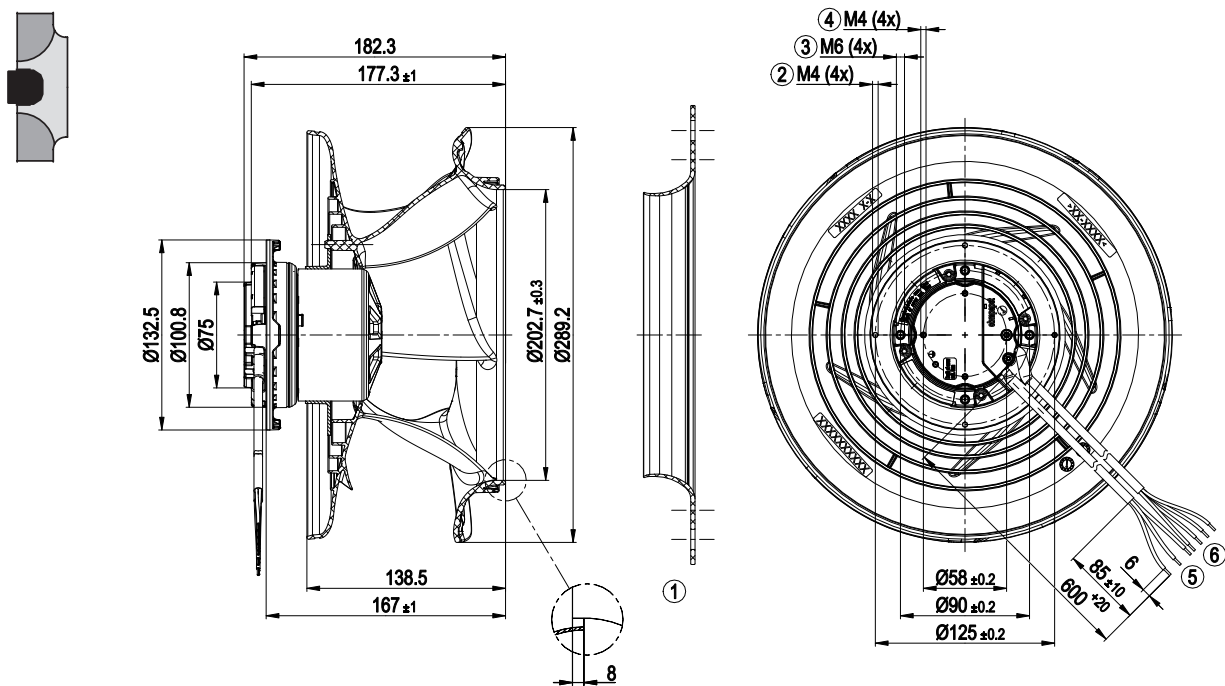

- ① Accessory part: Inlet ring 8217104581 with pressure tap (k-factor: 98) (not included in scope of delivery)
- ② Max. clearance for screw 10 mm
- ③ Max. clearance for screw 10 mm
- ④ Max. clearance for screw 5 mm
- ⑤ Cable PVC AWG20, 3x splice
- ⑥ Cable PVC AWG22, 4x splice

Pin assignment: See connection diagram  
 Mounting position: Shaft horizontal or rotor on bottom; rotor on top on request

# RadiPac 280

**D** VBS0280CSNGS 8300100483 EC centrifugal fan - RadiPac

Dimensions in mm

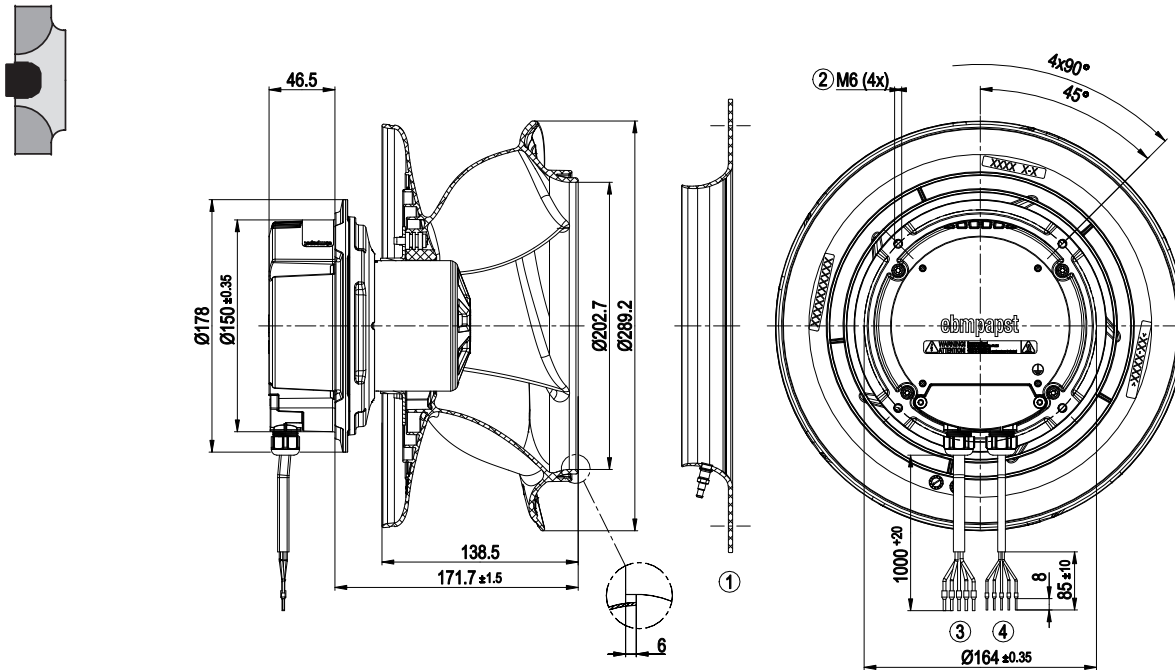

- ① Accessory part: Inlet ring 8217104581 with pressure tap (k-factor: 98) (not included in scope of delivery)
- ② Max. clearance for screw 16 mm
- ③ Cable PVC AWG18, 5x wire-end ferrule
- ④ Cable PVC AWG22

Pin assignment: See connection diagram  
 Mounting position: Shaft horizontal or rotor on bottom; rotor on top on request

**D** VBH0280CSNGS 8300100482 EC centrifugal module - RadiPac

Dimensions in mm

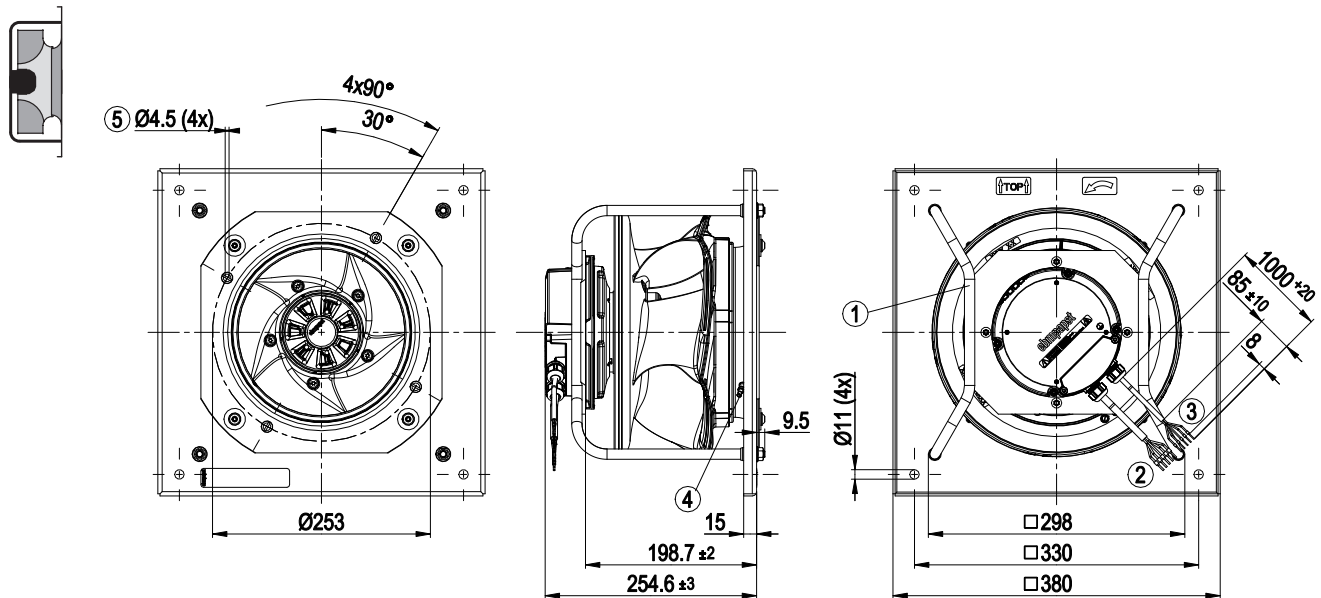

- ① Installed position: shaft horizontal (install support struts only vertically as illustrated) or rotor on bottom; rotor on top on request
- ② Cable PVC AWG18, 5x wire-end ferrule
- ③ Cable PVC AWG22
- ④ Inlet ring with pressure tap (k-factor: 98)
- ⑤ Fastening holes for FlowGrid 20280-2-2957 (not included in scope of delivery) are provided and must be subsequently opened as required

Pin assignment: See connection diagram  
 Mounting position: See legend on product drawing



# RadiPac 310

EC centrifugal fans, backward curved



## Material/Surface

- Support bracket: Steel, painted black
- Support plate: Sheet steel, galvanized
- Inlet nozzle: ABS plastic
- Impeller: PP plastic
- Rotor: Thick-film passivated, Painted black
- Electronics housing: Die-cast aluminum

## Mechanical characteristics

- Number of blades: 5
- Drehrichtung (epM): Clockwise, viewed toward rotor
- Installation position: Shaft horizontal or rotor on bottom; rotor on top on request, See legend on product drawing
- Condensation drainage holes: None, open rotor, On rotor side
- Mode: S1
- Motor bearing: Ball bearing

## Additional Information

- Information about touch current, electrical connection, degree of protection, insulation class, environmental protection class, EMC standards as well as standards and approvals can be found in the product-specific data sheets.

from page 32	Drawings
from page 92	Accessories
from page 102	Connection diagrams and technical equipment
from page 110	Environment and general conditions
More at	<a href="http://www.ebmpapst.com/worldwide">www.ebmpapst.com/worldwide</a> <a href="http://www.ebmpapst.com/">www.ebmpapst.com/</a>

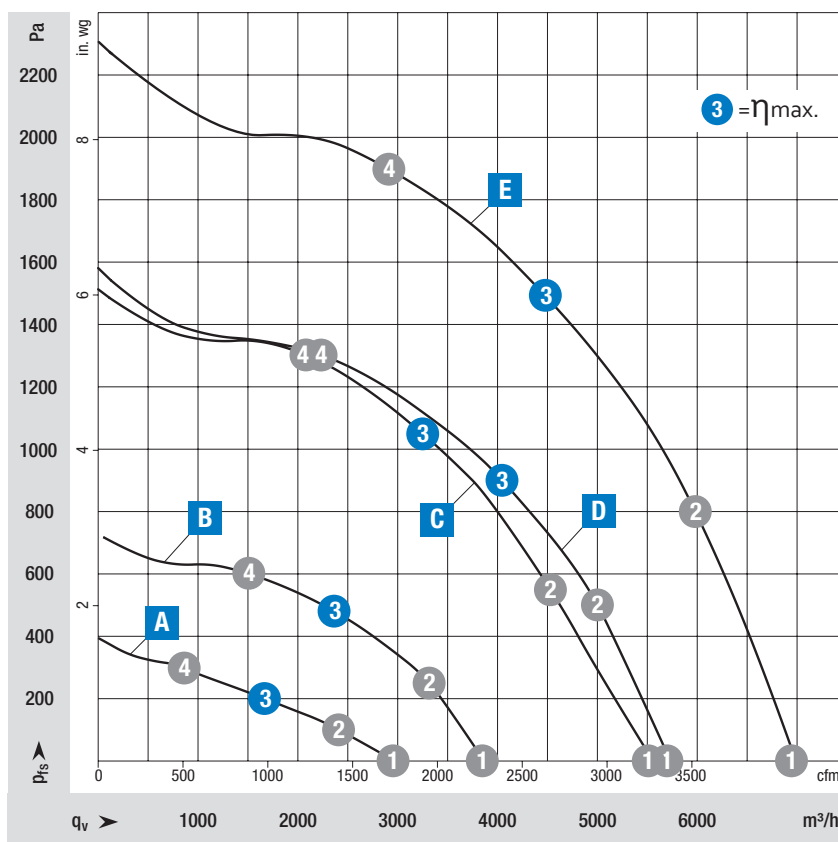









### Measuring conditions

Air performance measured after: ISO 5801, installation category A, with ebm-papst inlet nozzle without contact protection.

Suction-side noise level: LwA according to ISO 13347, LpA measured at a distance of 1 m on the fan axis.

The specifications apply only under the specified measuring conditions and may change due to installation conditions.

In case of deviations from the standard design, the characteristic values must be checked in the installed condition!

Nominal voltage range 1- 200-240 VAC, 50/60 Hz			Characteristic Curve	Operating point	Nominal voltage	Speed n	Max. Input power P <sub>ed</sub>	Max. Input current I	Sound power level L <sub>WA</sub>	Max. back pressure	Perm. ambient temp.	Protection class	Connection diagrams and technical equipment										
Type	Part number	Fan type			V	rpm	W	A	dB(A)	Pa	°C												
VBS0310CSNES	8300100572	Centrifugal fan		Short-version	A	1	230	1,985	165	1.40	75	-25...+45	IP54	Page 106									
						2	230	1,820	165	1.40	67												
						3	230	<b>1,700</b>	<b>165</b>	<b>1.40</b>	<b>61</b>												
						4	230	1,780	165	1.40	65												
Nominal voltage range 1- 200-277 VAC, 50/60 Hz					V	rpm	W	A	dB(A)	Pa	°C												
Type	Part number	Fan type			V	rpm	W	A	dB(A)	Pa	°C												
VBS0310CSNGS	8300100542	Centrifugal fan		Short-version	B	1	230	2,540	318	1.41	81	-25...+45	IP54	Page 105									
						2	230	2,540	447	1.96	73												
VBH0310CSNGS	8300100543	Support bracket		Short-version	B	3	230	<b>2,540</b>	<b>500</b>	<b>2.20</b>	<b>67</b>	-25...+45	IP54	Page 105									
						4	230	2,540	467	2.04	72												
Nominal voltage range 3- 380-480 VAC, 50/60 Hz					V	rpm	W	A	dB(A)	Pa	°C												
Type	Part number	Fan type			V	rpm	W	A	dB(A)	Pa	°C												
VBS0310CTPMS	8300100039	Centrifugal fan		Short-version	C	1	400	3,800	1,138	1.75	92	-40...+40	IP55	Page 103									
						2	400	3,800	1,416	2.16	85												
						3	400	<b>3,800</b>	<b>1,500</b>	<b>2.30</b>	<b>83</b>												
						4	400	3,800	1,418	2.17	88												
VBH0310CTPMS	8300100044	Support bracket		Short-version	C	3	400	<b>3,800</b>	<b>1,500</b>	<b>2.30</b>	<b>83</b>	-40...+40	IP55	Page 103									
						4	400	3,800	1,418	2.17	88												
						VBS0310CTPMS	8300100046	Centrifugal fan		Long-version	D				1	400	3,800	1,008	1.56	91	-40...+40	IP55	Page 103
															2	400	3,800	1,380	2.11	85			
VBH0310CTPMS	8300100053	Support bracket		Long-version	D	3	400	<b>3,800</b>	<b>1,500</b>	<b>2.40</b>	<b>82</b>	-40...+40	IP55	Page 103									
						4	400	3,800	1,470	2.24	86												
VBS0310CTRLS	8300100103	Centrifugal fan		Long-version	E	1	400	4,560	1,855	2.94	97	-40...+40	IP55	Page 102									
						2	400	4,560	2,547	3.96	90												
						3	400	<b>4,560</b>	<b>2,750</b>	<b>4.30</b>	<b>84</b>												
						4	400	4,560	2,619	4.06	89												
VBH0310CTRLS	8300100104	Support bracket		Long-version	E	3	400	<b>4,560</b>	<b>2,750</b>	<b>4.30</b>	<b>84</b>	-40...+40	IP55	Page 102									
						4	400	4,560	2,619	4.06	89												

Subject to changes.

Values set in blue are nominal data at the operating point at maximum load.

# RadiPac 310

A VBS0310CSNES 8300100572 EC centrifugal fan - RadiPac

Dimensions in mm

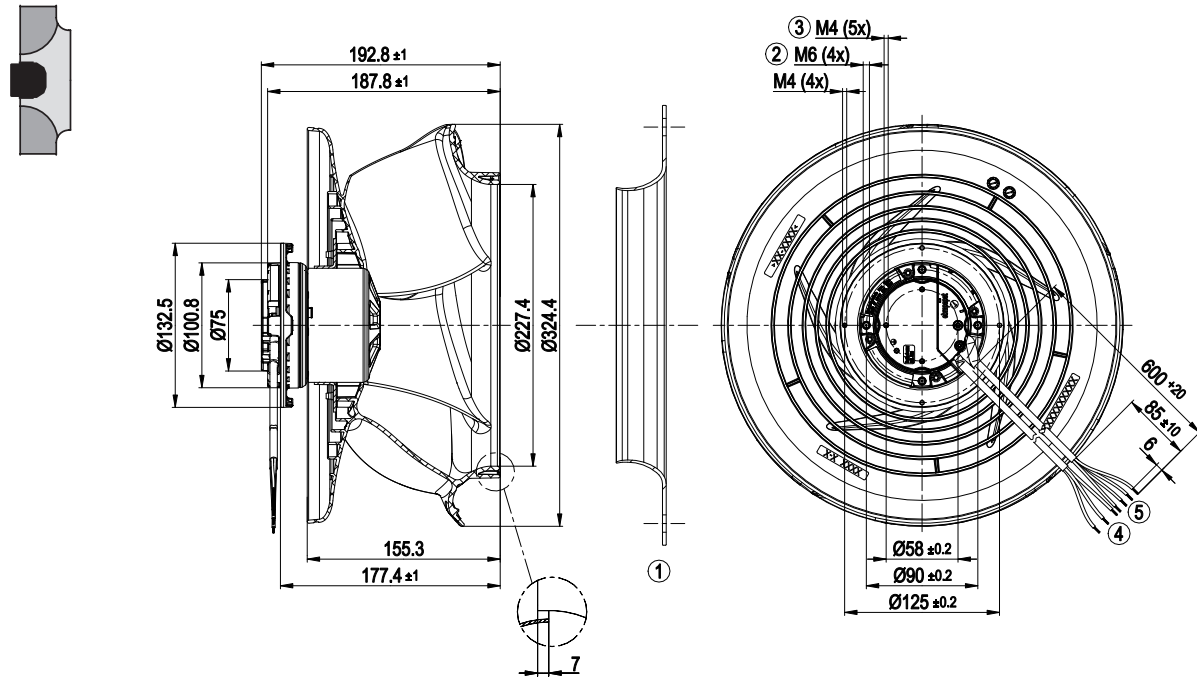

- ① Accessory part: Inlet ring 8217102242 with pressure tap (k-factor: 115) (not included in scope of delivery)
- ② Max. clearance for screw 10 mm
- ③ Max. clearance for screw 5 mm
- ④ Cable PVC AWG20, 3x splice
- ⑤ Cable PVC AWG22

Pin assignment: See connection diagram  
 Mounting position: Shaft horizontal or rotor on bottom; rotor on top on request



## B VBS0310CSNGS 8300100542 EC centrifugal fan - RadiPac

Dimensions in mm

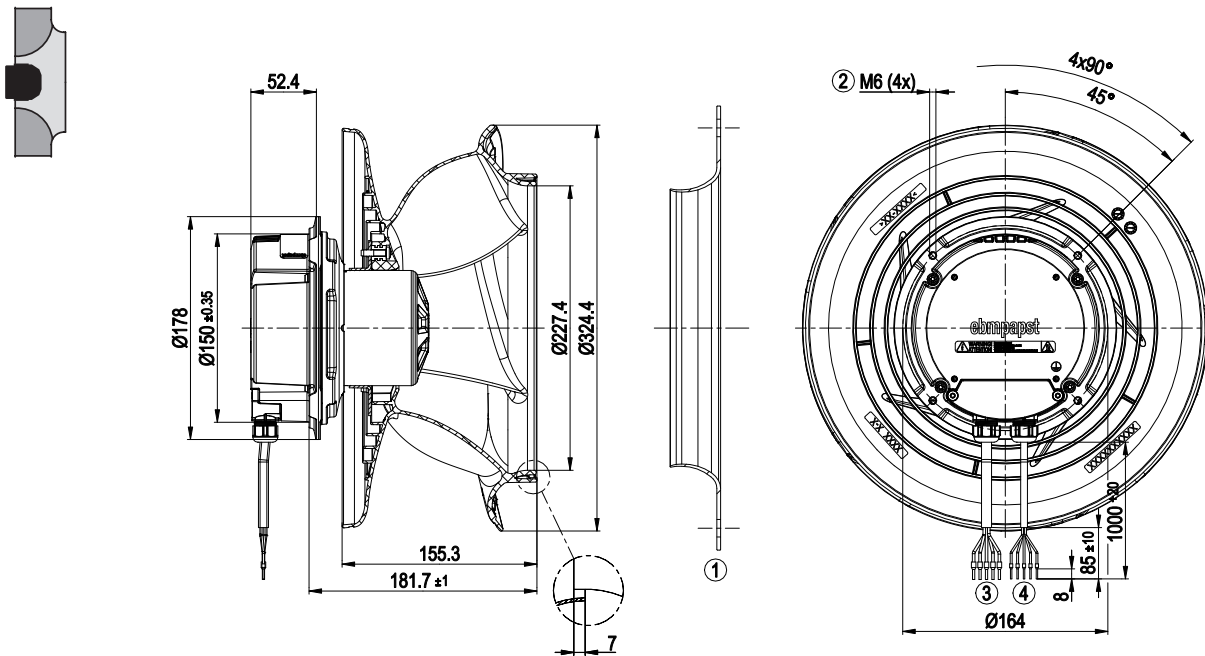

- ① Accessory part: Inlet ring 8217102242 with pressure tap (k-factor: 115) (not included in scope of delivery)
- ② Max. clearance for screw 10 mm
- ③ Cable PVC AWG18, 5x splice
- ④ Cable PVC AWG22

Pin assignment: See connection diagram  
 Mounting position: Shaft horizontal or rotor on bottom; rotor on top on request

## B VBH0310CSNGS 8300100543 EC centrifugal module - RadiPac

Dimensions in mm

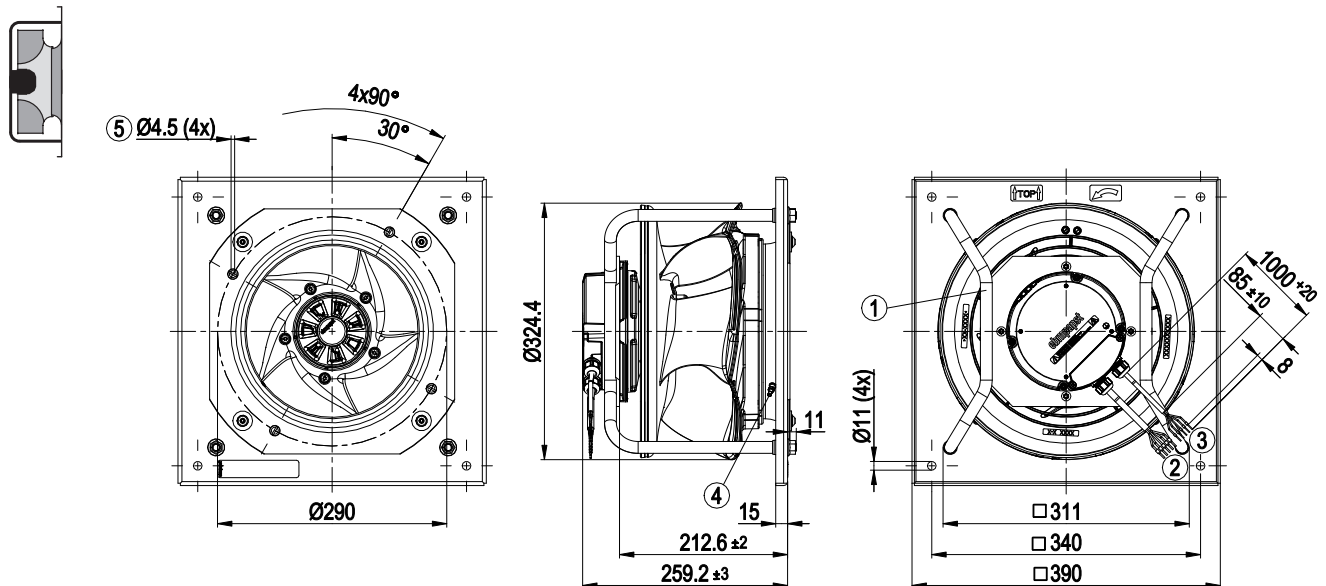

- ① Installed position: shaft horizontal (install support struts only vertically as illustrated) or rotor on bottom; rotor on top on request
- ② Cable PVC AWG18, 5x wire-end ferrule
- ③ Cable PVC AWG22
- ④ Inlet ring with pressure tap (k-factor: 115)
- ⑤ Fastening holes for FlowGrid 25310-2-2957 (not included in scope of delivery) are provided and must be subsequently opened as required

Pin assignment: See connection diagram  
 Mounting position: See legend on product drawing

# RadiPac 310

C VBS0310CTPMS 8300100039 EC centrifugal fan - RadiPac

Dimensions in mm

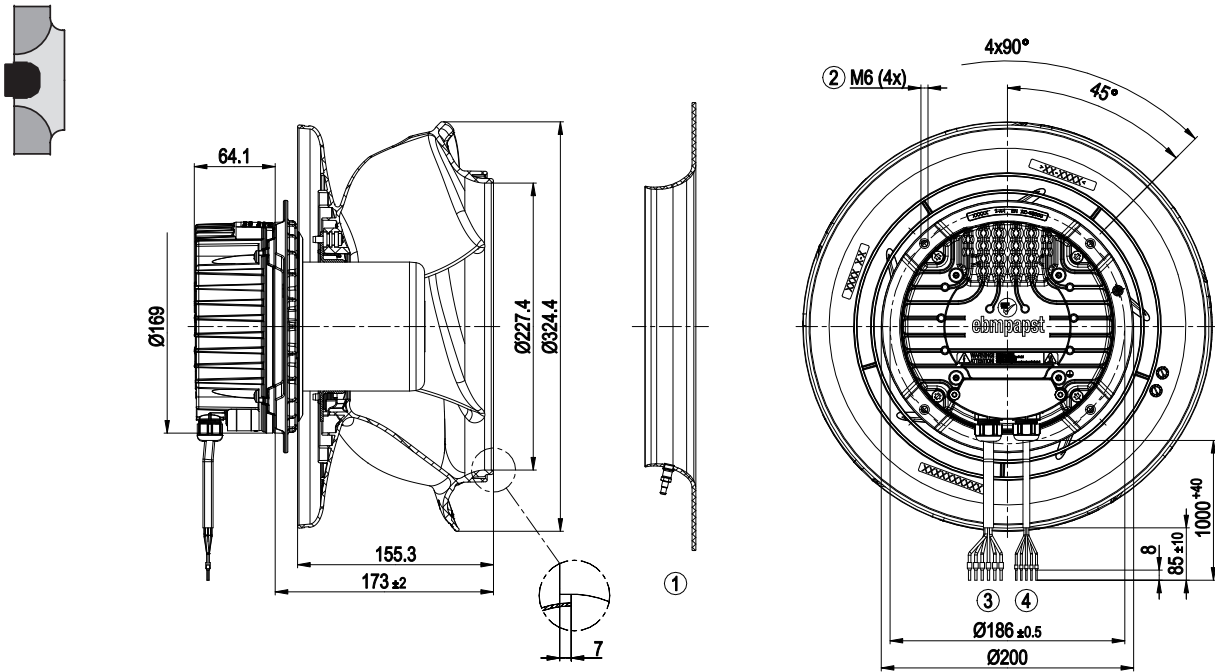

- ① Accessory part: Inlet ring 8217102242 with pressure tap (k-factor: 115) (not included in scope of delivery)
- ② Max. clearance for screw 16 mm
- ③ Cable PVC AWG18, 6x wire-end ferrule
- ④ Cable PVC AWG22

Pin assignment: See connection diagram  
 Mounting position: Shaft horizontal or rotor on bottom; rotor on top on request

C VBH0310CTPMS 8300100044 EC centrifugal module - RadiPac

Dimensions in mm

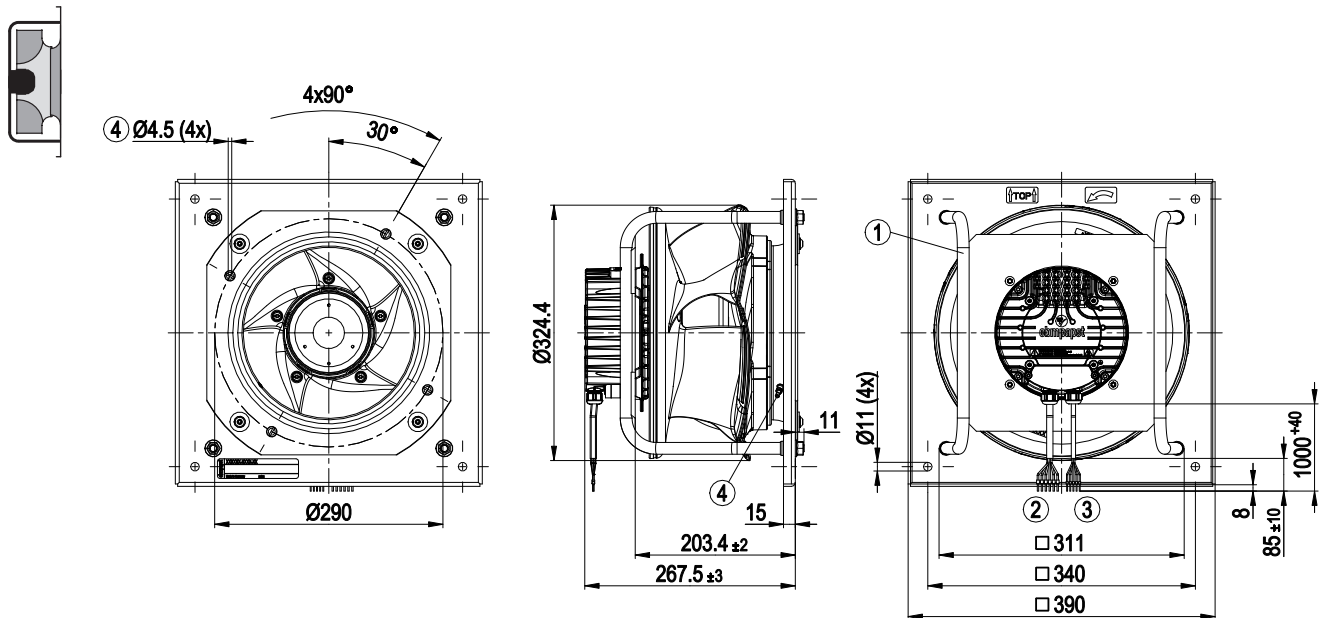

- ① Installed position: shaft horizontal (install support struts only vertically as illustrated) or rotor on bottom; rotor on top on request
- ② Cable PVC AWG18, 6x wire-end ferrule
- ③ Cable PVC AWG22
- ④ Inlet ring with pressure tap (k-factor: 115)
- ⑤ Fastening holes for FlowGrid 25310-2-2957 (not included in scope of delivery) are provided and must be subsequently opened as required

Pin assignment: See connection diagram  
 Mounting position: See legend on product drawing

## D VBS0310CTPMS 8300100046 EC centrifugal fan - RadiPac

Dimensions in mm

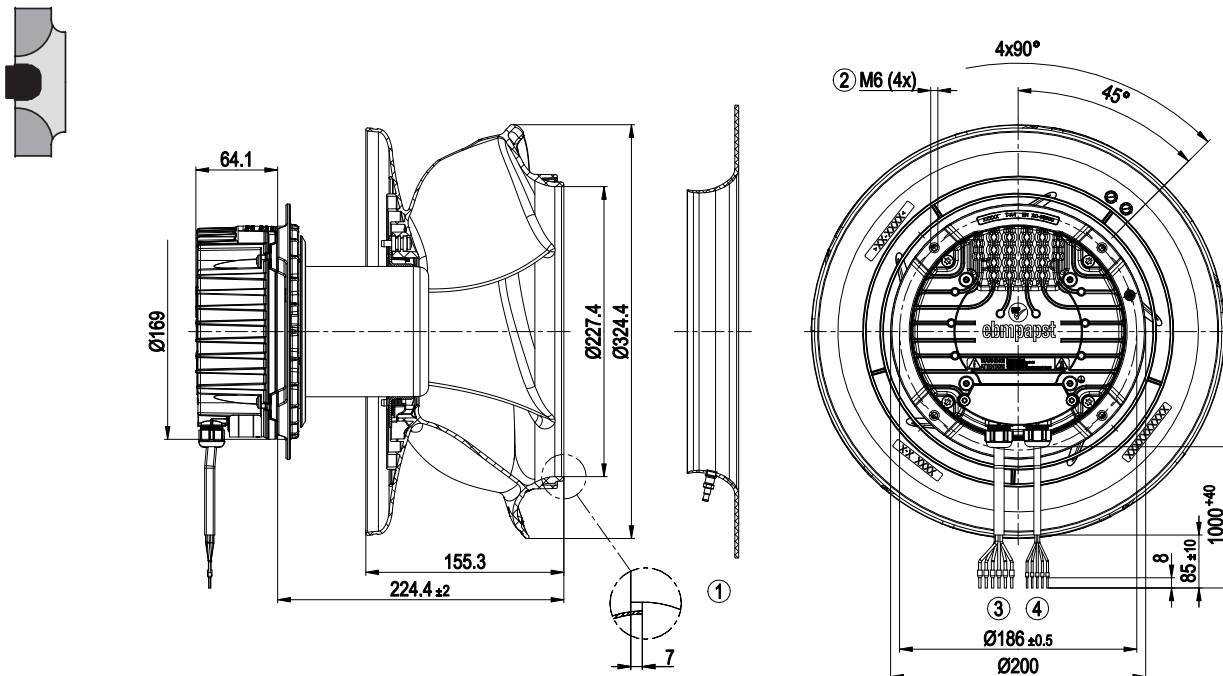

- ① Accessory part: Inlet ring 8217102242 with pressure tap (k-factor: 115) (not included in scope of delivery)
- ② Max. clearance for screw 16 mm
- ③ Cable PVC AWG18, 6x wire-end ferrule
- ④ Cable PVC AWG22

Pin assignment: See connection diagram  
 Mounting position: Shaft horizontal or rotor on bottom; rotor on top on request

## D VBH0310CTPMS 8300100053 EC centrifugal module - RadiPac

Dimensions in mm

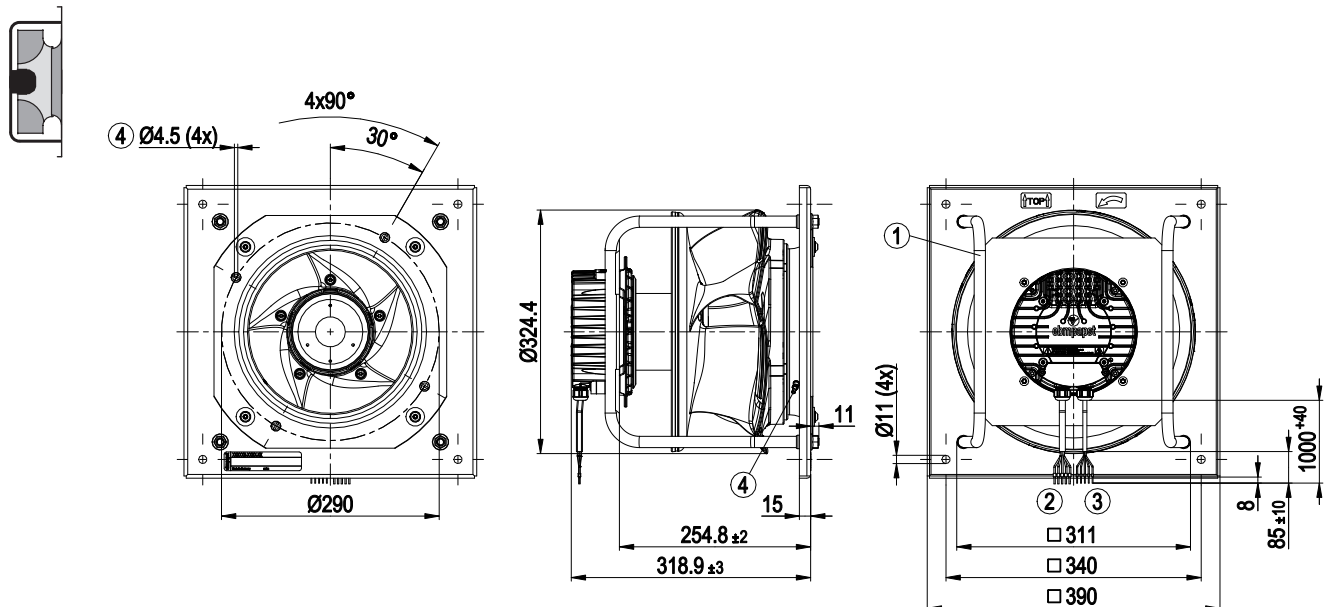

- ① Installed position: shaft horizontal (install support struts only vertically as illustrated) or rotor on bottom; rotor on top on request
- ② Cable PVC AWG18, 6x wire-end ferrule
- ③ Cable PVC AWG22
- ④ Inlet ring with pressure tap (k-factor: 115)
- ⑤ Fastening holes for FlowGrid 25310-2-2957 (not included in scope of delivery) are provided and must be subsequently opened as required

Pin assignment: See connection diagram  
 Mounting position: See legend on product drawing

# RadiPac 310

**E** VBS0310CTRLS 8300100103 EC centrifugal fan - RadiPac

Dimensions in mm

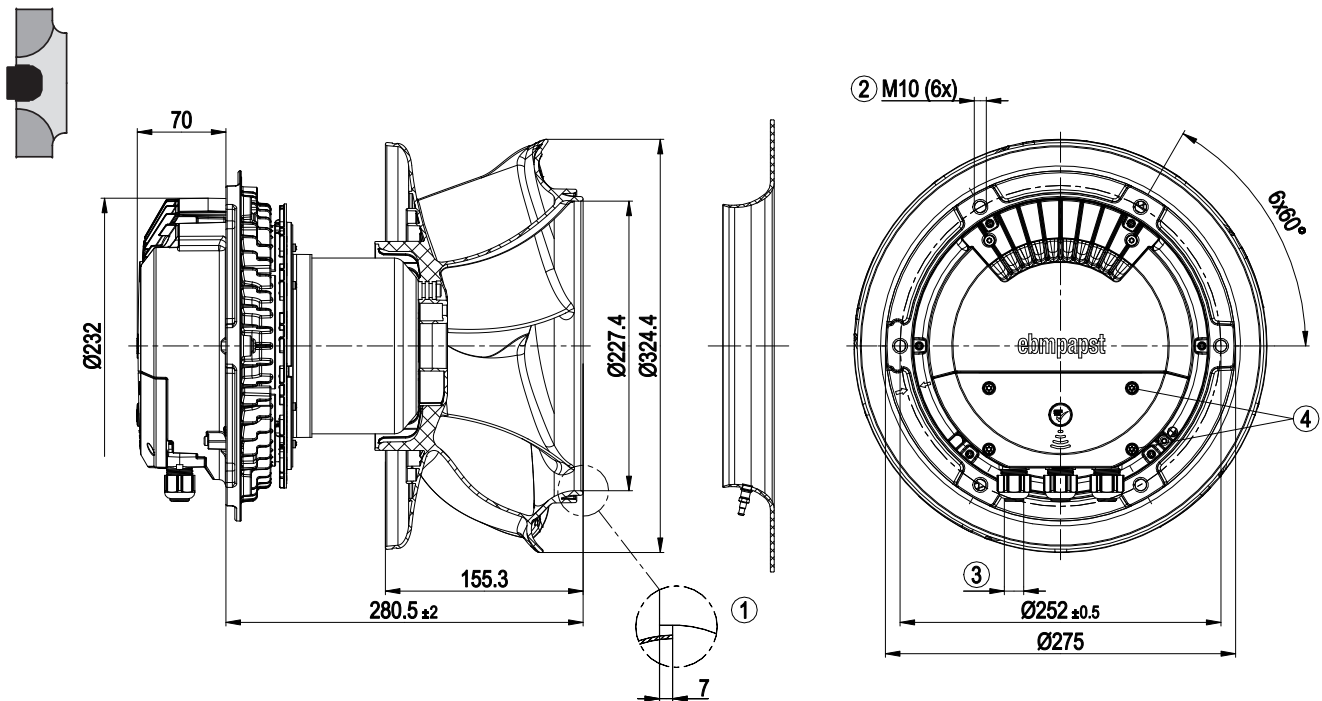

- ① Accessory part: Inlet ring 8217102242 with pressure tap (k-factor: 115) (not included in scope of delivery)
- ② Max. clearance for screw 20 mm
- ③ Cable diameter min. 4 mm, max. 10 mm, tightening torque  $4 \pm 0.6$  Nm  
(The tightening torque is designed for PVC cables. If the cable materials are different, the tightening torque may have to be adjusted)
- ④ Tightening torque  $1.5 \pm 0.2$  Nm

Pin assignment: See connection diagram  
Mounting position: Shaft horizontal or rotor on bottom; rotor on top on request

**E** VBH0310CTRLS 8300100104 EC centrifugal module - RadiPac

Dimensions in mm

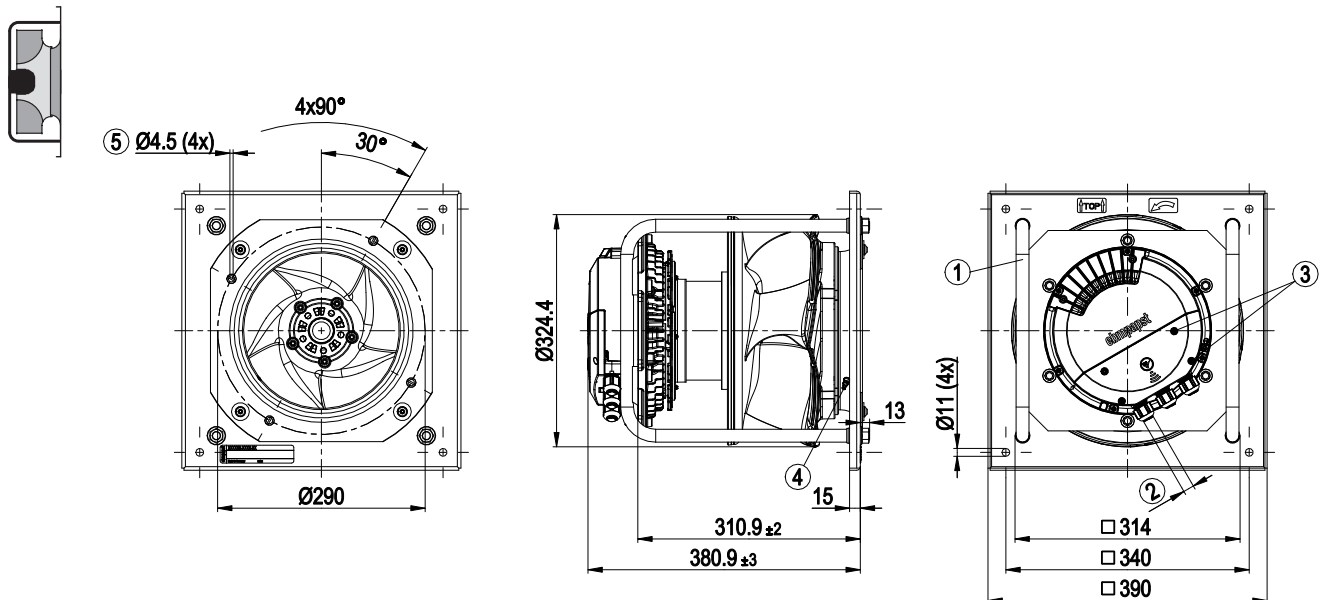

- ① Installed position: shaft horizontal (install support struts only vertically as illustrated) or rotor on bottom; rotor on top on request
- ② Cable diameter min. 4 mm, max. 10 mm, tightening torque  $4 \pm 0.6$  Nm  
(The tightening torque is designed for PVC cables. If the cable materials are different, the tightening torque may have to be adjusted)
- ③ Tightening torque  $1.5 \pm 0.2$  Nm
- ④ Inlet ring with pressure tap (k-factor: 115)
- ⑤ Fastening holes for FlowGrid 25310-2-2957 (not included in scope of delivery) are provided and must be subsequently opened as required

Pin assignment: See connection diagram  
Mounting position: See legend on product drawing



# RadiPac 355

EC centrifugal fans, backward curved



## Material/Surface

- Support bracket: Steel, painted black
- Support plate: Sheet steel, galvanized
- Inlet nozzle: ABS plastic
- Impeller: PP plastic
- Rotor: Thick-film passivated, Painted black
- Electronics housing: Die-cast aluminum

## Mechanical characteristics

- Number of blades: 5
- Drehrichtung (epM): Clockwise, viewed toward rotor
- Installation position: Shaft horizontal or rotor on bottom; rotor on top on request, See legend on product drawing
- Condensation drainage holes: None, open rotor, On rotor side
- Mode: S1
- Motor bearing: Ball bearing

## Additional Information

- Information about touch current, electrical connection, degree of protection, insulation class, environmental protection class, EMC standards as well as standards and approvals can be found in the product-specific data sheets.

from page 40	Drawings
from page 92	Accessories
from page 102	Connection diagrams and technical equipment
from page 110	Environment and general conditions
More at	<a href="http://www.ebmpapst.com/worldwide">www.ebmpapst.com/worldwide</a> <a href="http://www.ebmpapst.com/">www.ebmpapst.com/</a>

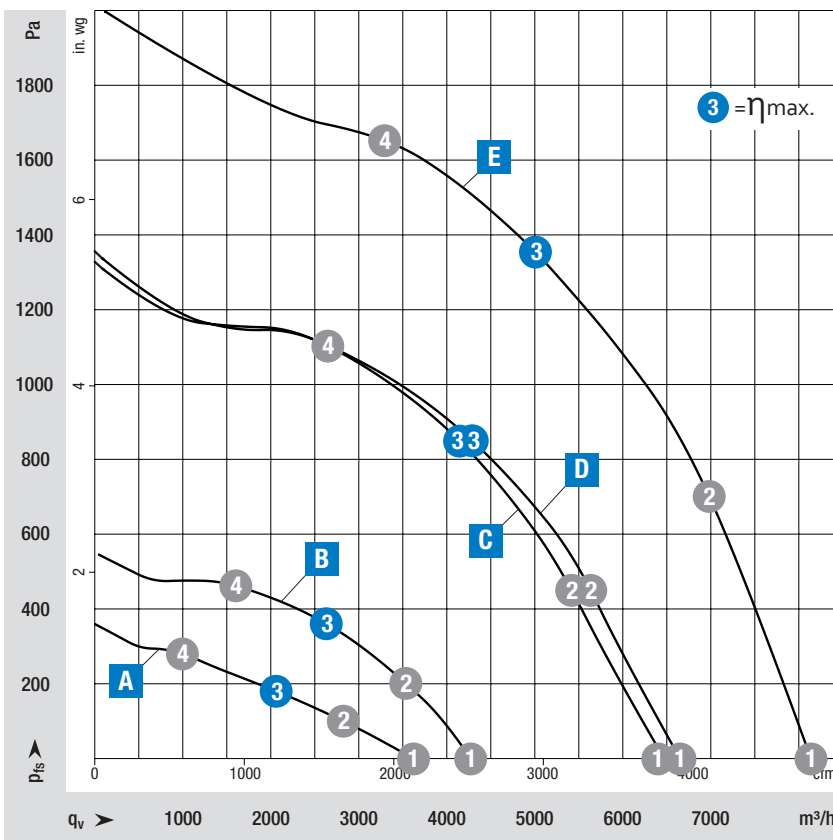









### Measuring conditions

Air performance measured after: ISO 5801, installation category A, with ebm-papst inlet nozzle without contact protection.

Suction-side noise level: L<sub>WA</sub> according to ISO 13347, L<sub>pA</sub> measured at a distance of 1 m on the fan axis.

The specifications apply only under the specified measuring conditions and may change due to installation conditions.

In case of deviations from the standard design, the characteristic values must be checked in the installed condition!

Nominal voltage range 1- 200-240 VAC, 50/60 Hz			Characteristic Curve	Operating point	Nominal voltage	Speed n	Max. Input power P <sub>ed</sub>	Max. Input current I	Sound power level L <sub>WA</sub>	Max. back pressure	Perm. ambient temp.	Protection class	Connection diagrams and technical equipment		
Type	Part number	Fan type			V	rpm	W	A	dB(A)	Pa	°C				
VBS0355CSNES	8300100537	Centrifugal fan		Short-version	A	1	230	1,675	165	1.40	75	---	-25...+50	IP54	Page 106
						2	230	1,505	165	1.40	66				
						3	230	1,450	165	1.40	61				
						4	230	1,520	165	1.40	63				
Nominal voltage range 1- 200-277 VAC, 50/60 Hz					V	rpm	W	A	dB(A)	Pa	°C				
Type	Part number	Fan type													
VBS0355CSNGS	8300100538	Centrifugal fan		Short-version	B	1	230	2,000	284	1.26	78	---	-25...+55	IP54	Page 105
						2	230	2,000	372	1.64	71				
VBH0355CSNGS	8300100540	Support bracket		Short-version		3	230	2,000	430	1.90	67	---	-25...+55	IP54	Page 105
						4	230	2,000	400	1.76	69				
Nominal voltage range 3- 380-480 VAC, 50/60 Hz					V	rpm	W	A	dB(A)	Pa	°C				
Type	Part number	Fan type													
VBS0355CTPMS	8300100050	Centrifugal fan		Short-version	C	1	400	3,100	1,049	1.62	92	---	-40...+40	IP55	Page 103
						2	400	3,100	1,373	2.10	84				
						3	400	3,100	1,500	2.30	81				
						4	400	3,100	1,416	2.16	83				
VBH0355CTPMS	8300100054	Support bracket		Short-version		1	400	3,100	1,049	1.62	92	---	-40...+40	IP55	Page 103
						2	400	3,100	1,373	2.10	84				
						3	400	3,100	1,500	2.30	81				
						4	400	3,100	1,416	2.16	83				
VBS0355CTPMS	8300100040	Centrifugal fan		Long-version	D	1	400	3,100	950	1.47	90	---	-40...+40	IP55	Page 103
						2	400	3,100	1,362	2.08	83				
						3	400	3,100	1,500	2.30	79				
						4	400	3,100	1,401	2.14	82				
VBH0355CTPMS	8300100049	Support bracket		Long-version		1	400	3,100	950	1.47	90	---	-40...+40	IP55	Page 103
						2	400	3,100	1,362	2.08	83				
						3	400	3,100	1,500	2.30	79				
						4	400	3,100	1,401	2.14	82				
VBS0355CTRLS	8300100086	Centrifugal fan		Long-version	E	1	400	3,800	1,772	2.81	96	---	-40...+40	IP55	Page 102
						2	400	3,800	2,494	3.87	89				
						3	400	3,800	2,750	4.30	83				
						4	400	3,800	2,582	4.00	87				
VBH0355CTRLS	8300100087	Support bracket		Long-version		1	400	3,800	1,772	2.81	96	---	-40...+40	IP55	Page 102
						2	400	3,800	2,494	3.87	89				
						3	400	3,800	2,750	4.30	83				
						4	400	3,800	2,582	4.00	87				

Subject to changes.

Values set in blue are nominal data at the operating point at maximum load.

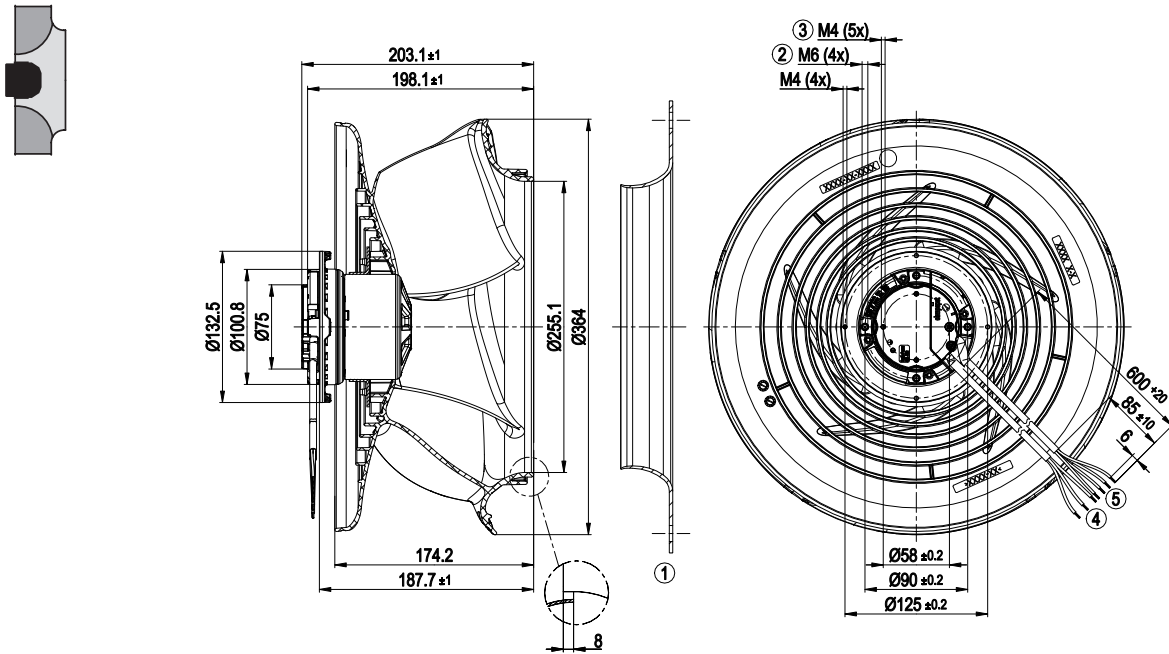

- ① Accessory part: Inlet ring 8217102240 with pressure tap (k-factor: 145) (not included in scope of delivery)
- ② Max. clearance for screw 10 mm
- ③ Max. clearance for screw 5 mm
- ④ Cable PVC AWG20, 3x splice
- ⑤ Cable PVC AWG22

Pin assignment: See connection diagram  
 Mounting position: Shaft horizontal or rotor on bottom; rotor on top on request



**B** VBS0355CSNGS 8300100538 EC centrifugal fan - RadiPac

Dimensions in mm

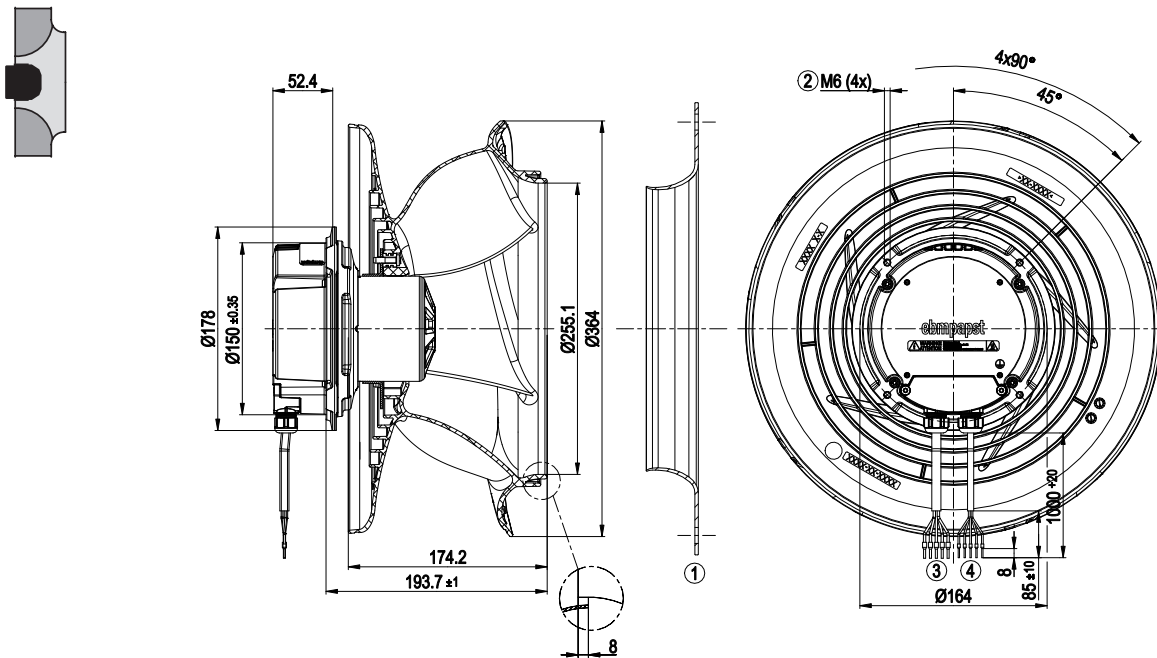

- ① Accessory part: Inlet ring 8217102240 with pressure tap (k-factor: 145) (not included in scope of delivery)
- ② Max. clearance for screw 10 mm
- ③ Cable PVC AWG18, 5x splice
- ④ Cable PVC AWG22

Pin assignment: See connection diagram  
 Mounting position: Shaft horizontal or rotor on bottom; rotor on top on request

**B** VBH0355CSNGS 8300100540 EC centrifugal module - RadiPac

Dimensions in mm

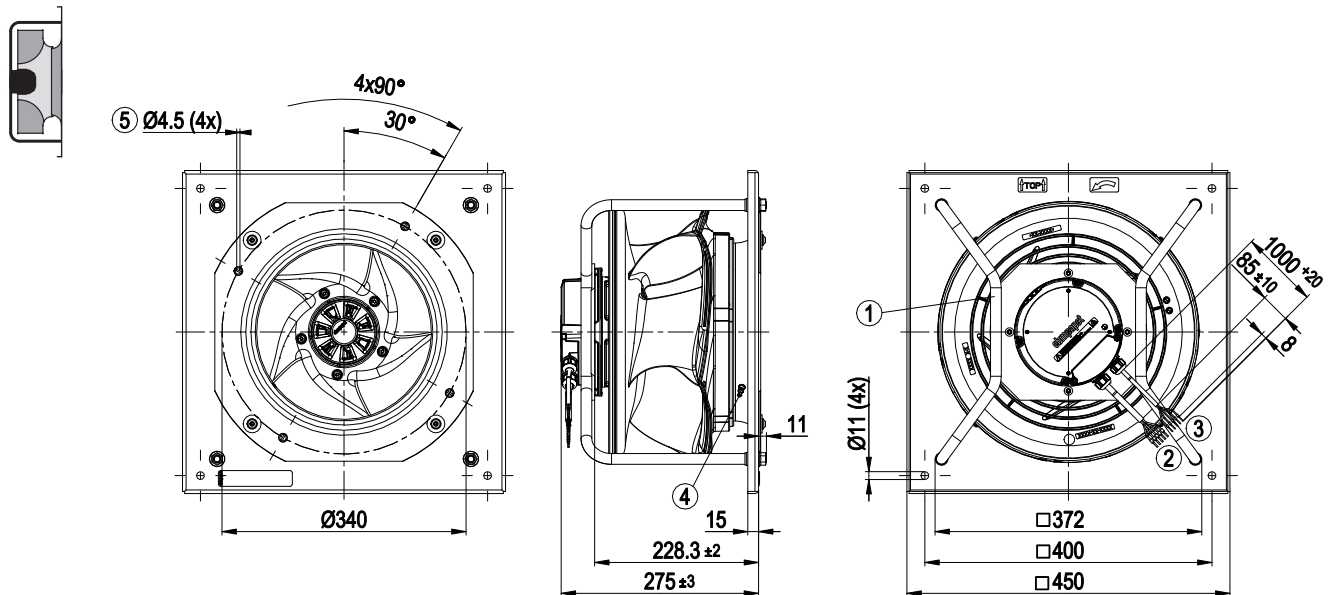

- ① Installed position: shaft horizontal (install support struts only vertically as illustrated) or rotor on bottom; rotor on top on request
- ② Cable PVC AWG18, 5x wire-end ferrule
- ③ Cable PVC AWG22
- ④ Inlet ring with pressure tap (k-factor: 145)
- ⑤ Fastening holes for FlowGrid 00400-2-2957 (not included in scope of delivery) are provided and must be subsequently opened as required

Pin assignment: See connection diagram  
 Mounting position: See legend on product drawing

# RadiPac 355

C VBS0355CTPMS 8300100050 EC centrifugal fan - RadiPac

Dimensions in mm

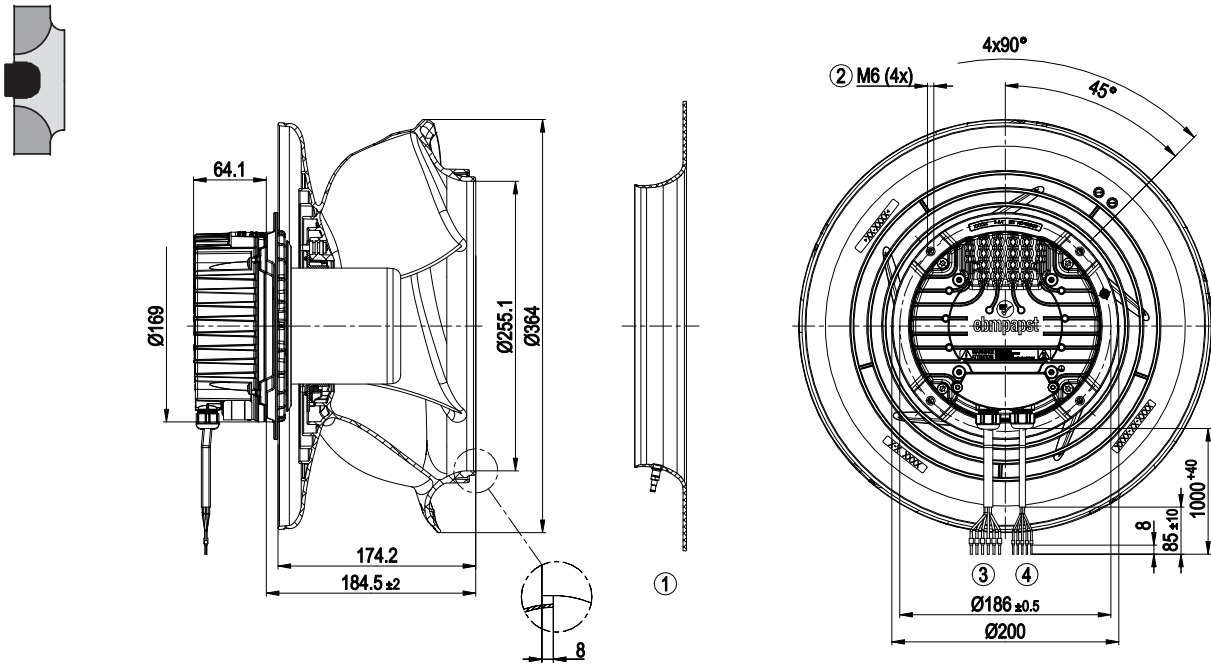

- ① Accessory part: Inlet ring 8217102240 with pressure tap (k-factor: 145) (not included in scope of delivery)
- ② Max. clearance for screw 16 mm
- ③ Cable PVC AWG18, 6x wire-end ferrule
- ④ Cable PVC AWG22

Pin assignment: See connection diagram  
Mounting position: Shaft horizontal or rotor on bottom; rotor on top on request

C VBH0355CTPMS 8300100054 EC centrifugal module - RadiPac

Dimensions in mm

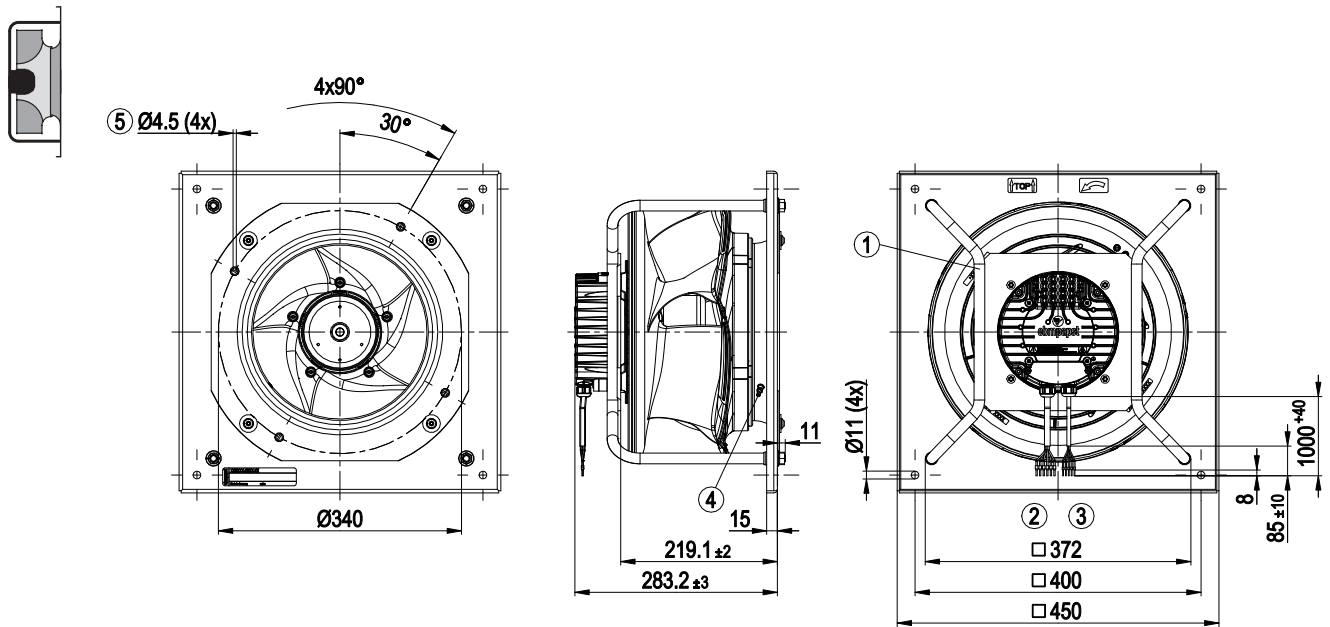

- ① Installed position: shaft horizontal (install support struts only vertically as illustrated) or rotor on bottom; rotor on top on request
- ② Cable PVC AWG18, 6x wire-end ferrule
- ③ Cable PVC AWG22
- ④ Inlet ring with pressure tap (k-factor: 145)
- ⑤ Fastening holes for FlowGrid 00400-2-2957 (not included in scope of delivery) are provided and must be subsequently opened as required

Pin assignment: See connection diagram  
Mounting position: See legend on product drawing

## D VBS0355CTPMS 8300100040 EC centrifugal fan - RadiPac

Dimensions in mm

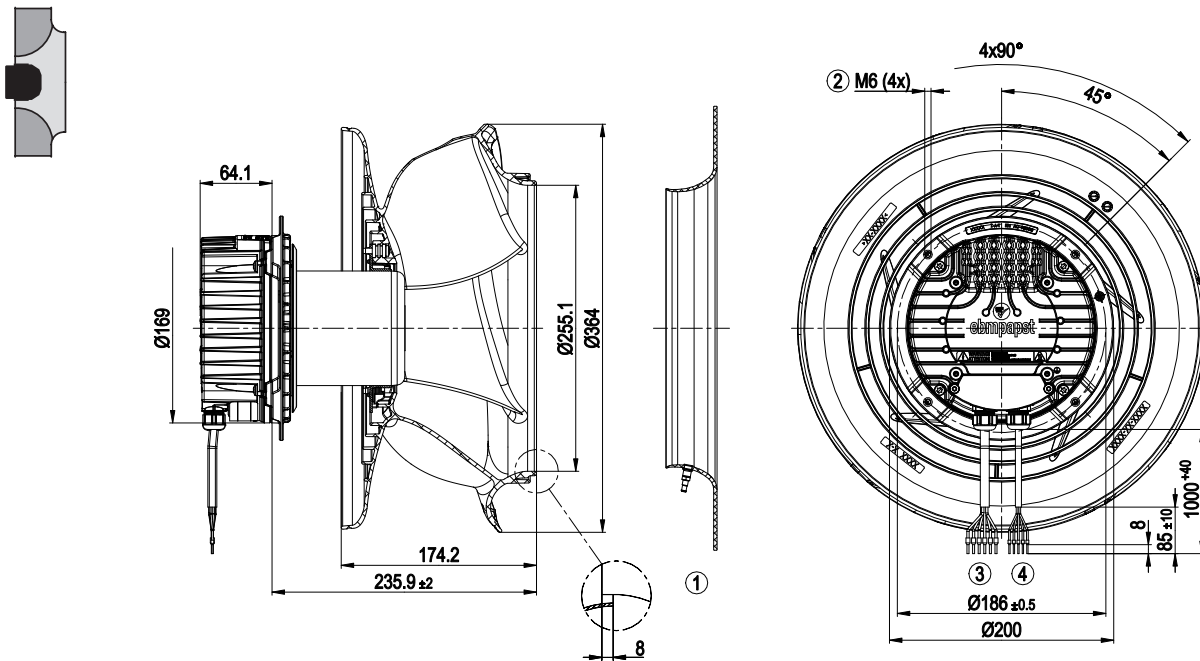

- ① Accessory part: Inlet ring 8217102240 with pressure tap (k-factor: 145) (not included in scope of delivery)
- ② Max. clearance for screw 16 mm
- ③ Cable PVC AWG18, 6x wire-end ferrule
- ④ Cable PVC AWG22

Pin assignment: See connection diagram  
 Mounting position: Shaft horizontal or rotor on bottom; rotor on top on request

## D VBH0355CTPMS 8300100049 EC centrifugal module - RadiPac

Dimensions in mm

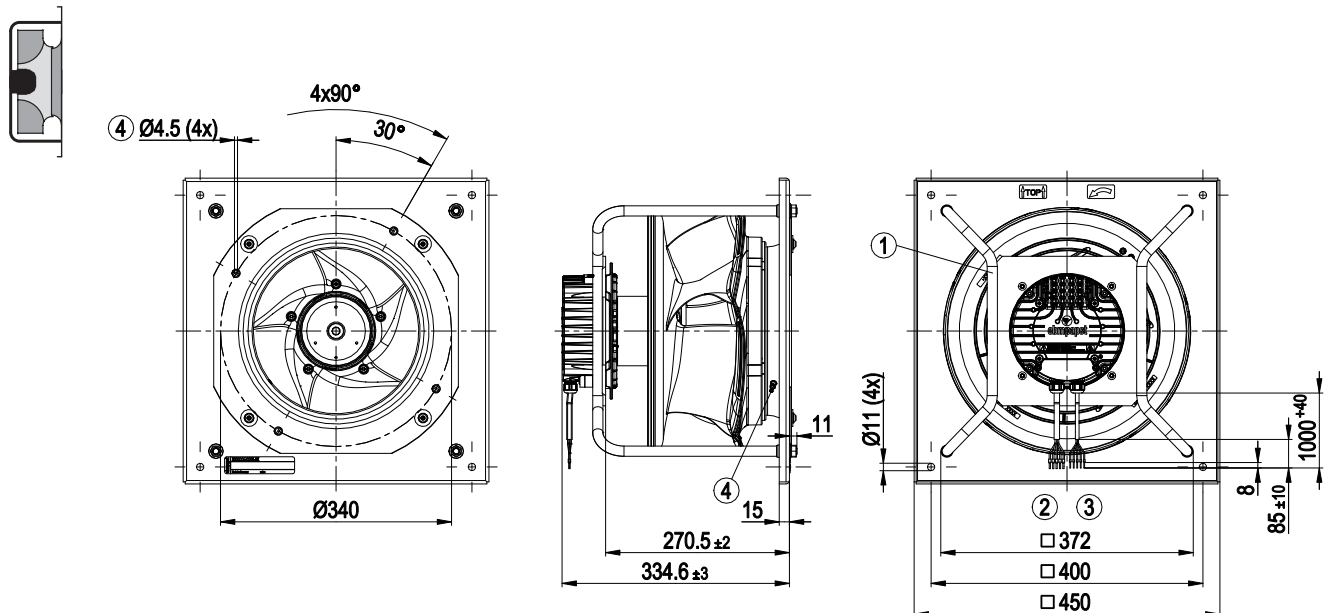

- ① Installed position: shaft horizontal (install support struts only vertically as illustrated) or rotor on bottom; rotor on top on request
- ② Cable PVC AWG18, 6x wire-end ferrule
- ③ Cable PVC AWG22
- ④ Inlet ring with pressure tap (k-factor: 145)
- ⑤ Fastening holes for FlowGrid 00400-2-2957 (not included in scope of delivery) are provided and must be subsequently opened as required

Pin assignment: See connection diagram  
 Mounting position: See legend on product drawing

# RadiPac 355

**E** VBS0355CTRLS 8300100086 EC centrifugal fan - RadiPac

Dimensions in mm

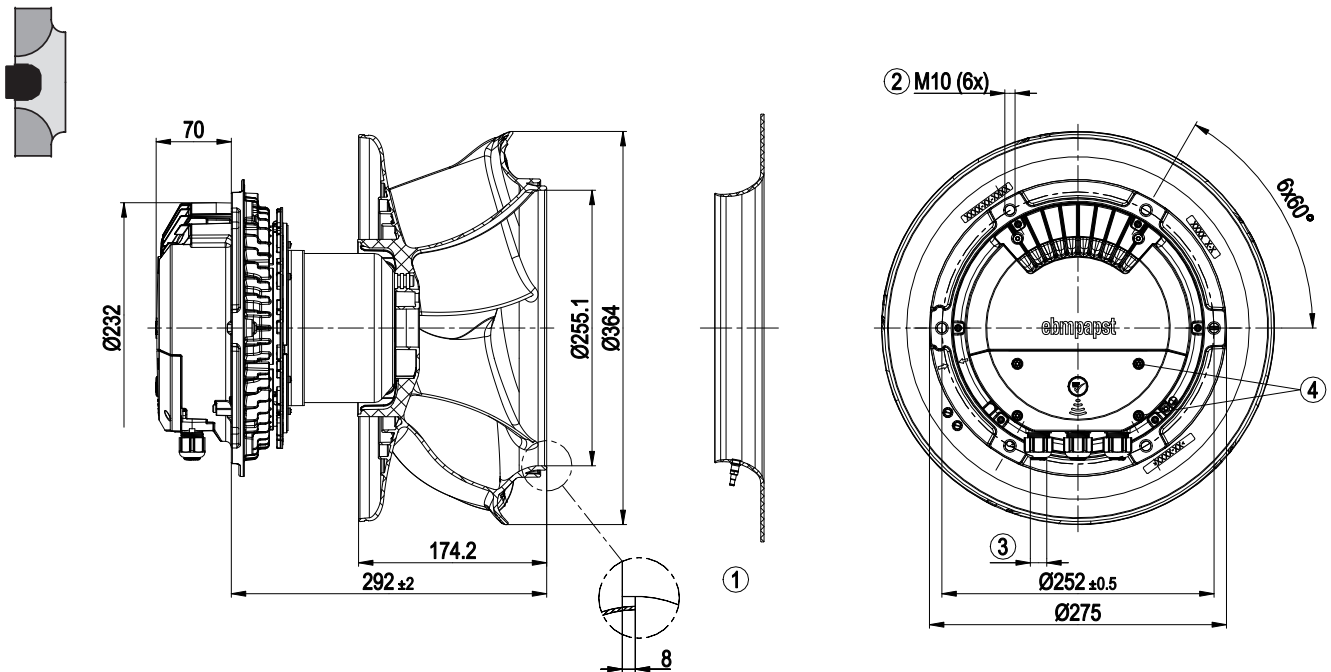

- ① Accessory part: Inlet ring 8217102240 with pressure tap (k-factor: 145) (not included in scope of delivery)
- ② Max. clearance for screw 20 mm
- ③ Cable diameter min. 4 mm, max. 10 mm, tightening torque  $4 \pm 0.6$  Nm  
(The tightening torque is designed for PVC cables. If the cable materials are different, the tightening torque may have to be adjusted)
- ④ Tightening torque  $1.5 \pm 0.2$  Nm

Pin assignment: See connection diagram  
Mounting position: Shaft horizontal or rotor on bottom; rotor on top on request

**E** VBH0355CTRLS 8300100087 EC centrifugal module - RadiPac

Dimensions in mm

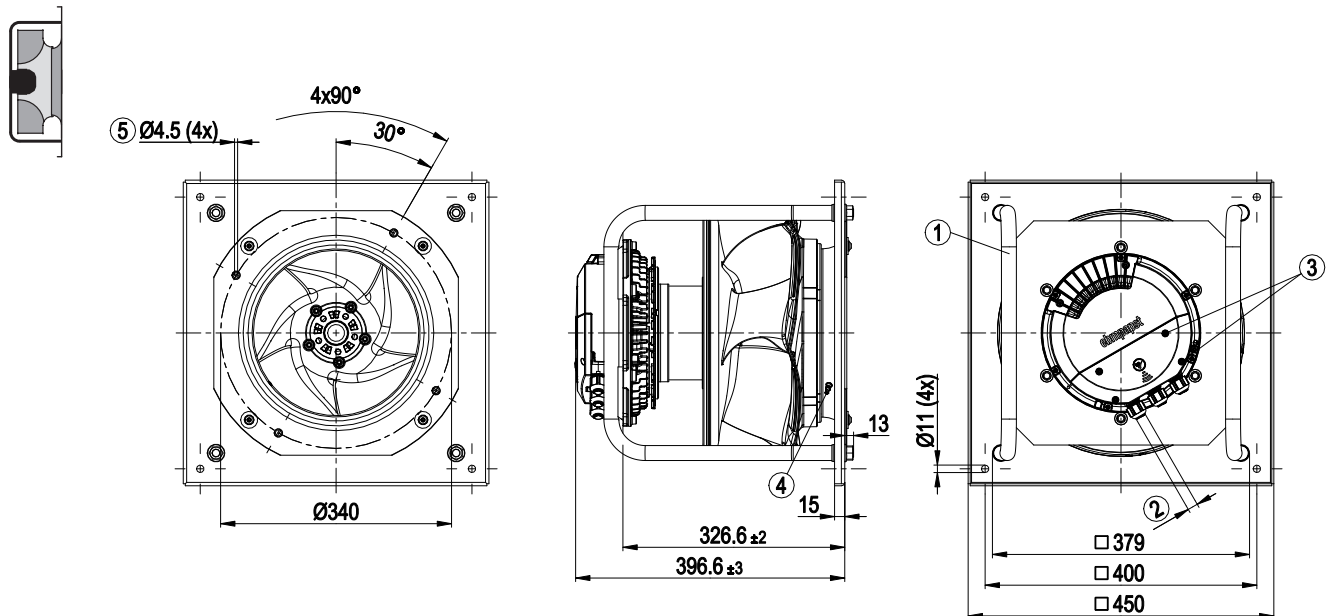

- ① Installed position: shaft horizontal (install support struts only vertically as illustrated) or rotor on bottom; rotor on top on request
- ② Cable diameter min. 4 mm, max. 10 mm, tightening torque  $4 \pm 0.6$  Nm  
(The tightening torque is designed for PVC cables. If the cable materials are different, the tightening torque may have to be adjusted)
- ③ Tightening torque  $1.5 \pm 0.2$  Nm
- ④ Inlet ring with pressure tap (k-factor: 145)
- ⑤ Fastening holes for FlowGrid 00400-2-2957 (not included in scope of delivery) are provided and must be subsequently opened as required

Pin assignment: See connection diagram  
Mounting position: See legend on product drawing



# RadiPac 400

EC centrifugal fans, backward curved



## Material/Surface

- Support bracket: Steel, painted black
- Support plate: Sheet steel, galvanized
- Inlet nozzle: ABS plastic
- Impeller: PP plastic
- Rotor: Painted black
- Electronics housing: Die-cast aluminum

## Mechanical characteristics

- Number of blades: 5
- Drehrichtung (epM): Clockwise, viewed toward rotor
- Installation position: Shaft horizontal or rotor on bottom; rotor on top on request, See legend on product drawing
- Condensation drainage holes: On rotor side
- Mode: S1
- Motor bearing: Ball bearing

## Additional Information





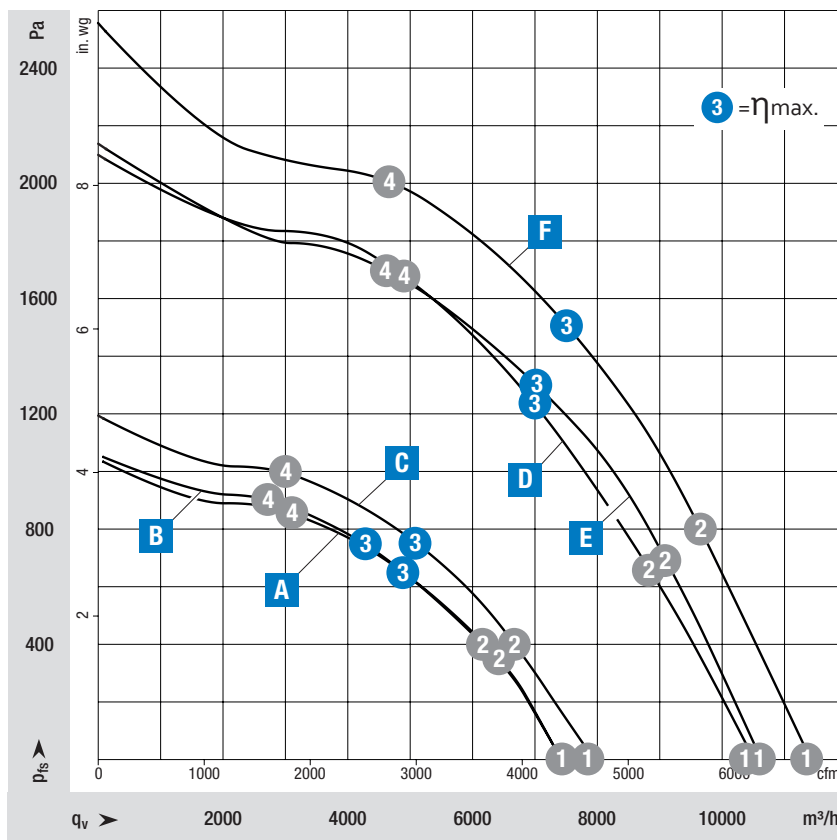







- Information about touch current, electrical connection, degree of protection, insulation class, environmental protection class, EMC standards as well as standards and approvals can be found in the product-specific data sheets.

from page 48	Drawings
from page 92	Accessories
from page 102	Connection diagrams and technical equipment
from page 110	Environment and general conditions
More at	<a href="http://www.ebmpapst.com/worldwide">www.ebmpapst.com/worldwide</a> <a href="http://www.ebmpapst.com/">www.ebmpapst.com/</a>



### Measuring conditions

Air performance measured after: ISO 5801, installation category A, with ebm-papst inlet nozzle without contact protection.  
Suction-side noise level: L<sub>WA</sub> according to ISO 13347, L<sub>pA</sub> measured at a distance of 1 m on the fan axis.  
The specifications apply only under the specified measuring conditions and may change due to installation conditions.  
In case of deviations from the standard design, the characteristic values must be checked in the installed condition!

Nominal voltage range 3- 380-480 VAC, 50/60 Hz			Characteristic Curve	Operating point	Nominal voltage	Speed n	Max. Input power P <sub>ed</sub>	Max. Input current I	Sound power level L <sub>WA</sub>	Max. back pressure	Perm. ambient temp.	Protection class	Connection diagrams and technical equipment
Type	Part number	Fan type			V	rpm	W	A	dB(A)	Pa	°C		
VBS0400CTPMS	8300100465	Centrifugal fan	 Short-version	A	400	2,480	942	1.46	86	---	-40...+40	IP55	Page 103
					400	2,480	1,242	1.91	79				
					<b>400</b>	<b>2,480</b>	<b>1,400</b>	<b>2.20</b>	<b>76</b>				
					400	2,480	1,292	1.98	80				
VBH0400CTPMS	8300100466	Support bracket	 Short-version										
VBS0400CTRHS	8300100480	Centrifugal fan	 Long-version	B	400	2,450	865	1.35	86	---	-40...+40	IP55	Page 103
					400	2,450	1,159	1.78	79				
					<b>400</b>	<b>2,450</b>	<b>1,300</b>	<b>2.00</b>	<b>74</b>				
					400	2,450	1,245	1.91	78				
VBH0400CTRHS	8300100479	Support bracket	 Long-version										
VBS0400CTRHS	8300100055	Centrifugal fan	 Short-version	C	400	2,600	1,105	1.70	90	---	-40...+40	IP55	Page 103
					400	2,600	1,441	2.20	83				
					<b>400</b>	<b>2,600</b>	<b>1,500</b>	<b>2.40</b>	<b>79</b>				
					400	2,600	1,453	2.22	82				
VBH0400CTRHS	8300100056	Support bracket	 Short-version										
VBS0400CTRNS	8300100077	Centrifugal fan	 Short-version	D	400	3,540	2,880	4.42	101	---	-40...+40	IP55	Page 102
					400	3,540	3,420	5.25	94				
					<b>400</b>	<b>3,540</b>	<b>3,740</b>	<b>5.80</b>	<b>89</b>				
					400	3,540	3,675	5.64	88				
VBH0400CTRNS	8300100078	Support bracket	 Short-version										
VBS0400CTRNS	8300100059	Centrifugal fan	 Long-version	E	400	3,430	2,350	3.65	97	---	-40...+40	IP55	Page 102
					400	3,430	3,241	4.96	91				
					<b>400</b>	<b>3,430</b>	<b>3,600</b>	<b>5.50</b>	<b>85</b>				
					400	3,430	3,481	5.30	85				
VBH0400CTRNS	8300100058	Support bracket	 Long-version										
VBS0400CTTLS	8300100127	Centrifugal fan	 Long-version	F	400	3,690	3,128	4.80	99	---	-40...+40	IP55	Page 102
					400	3,690	4,097	6.25	92				
					<b>400</b>	<b>3,690</b>	<b>4,500</b>	<b>6.90</b>	<b>84</b>				
					400	3,690	4,231	6.43	86				
VBH0400CTTLS	8300100128	Support bracket	 Long-version										

Subject to changes.

Values set in blue are nominal data at the operating point at maximum load.

# RadiPac 400

**A** VBS0400CTPMS 8300100465 EC centrifugal fan - RadiPac

Dimensions in mm

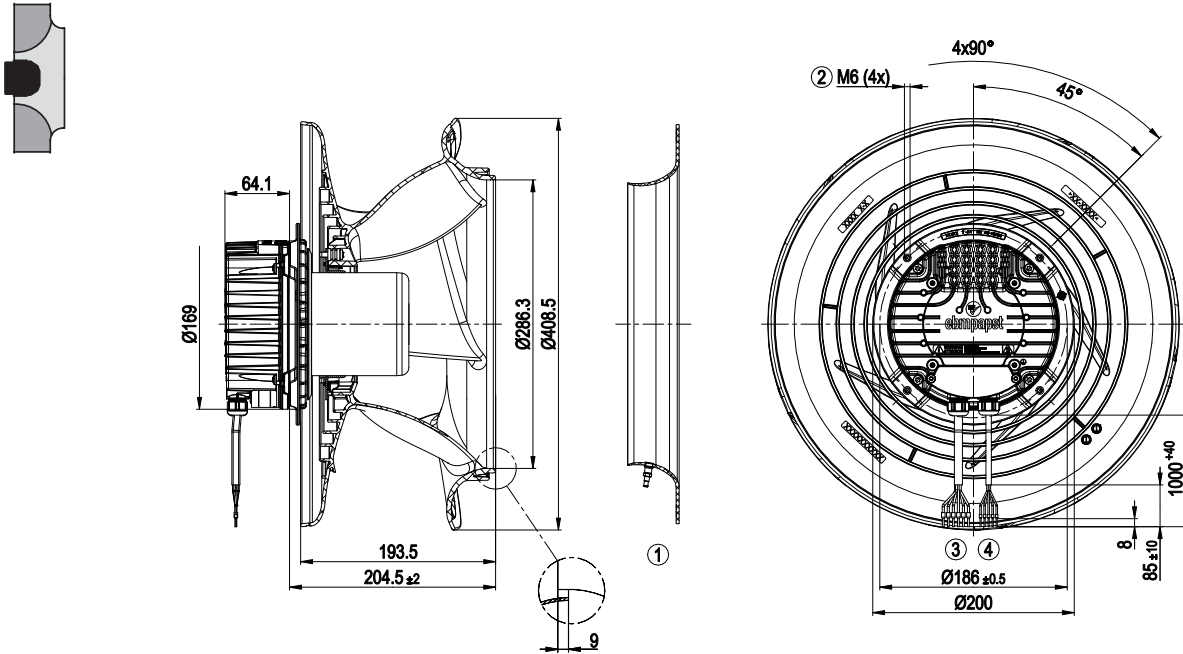

- ① Accessory part: Inlet ring 8217102241 with pressure tap (k-factor: 190) (not included in scope of delivery)
- ② Max. clearance for screw 16 mm
- ③ Cable PVC AWG18, 6x wire-end ferrule
- ④ Cable PVC AWG22

Pin assignment: See connection diagram  
Mounting position: Shaft horizontal or rotor on bottom; rotor on top on request

**A** VBH0400CTPMS 8300100466 EC centrifugal module - RadiPac

Dimensions in mm

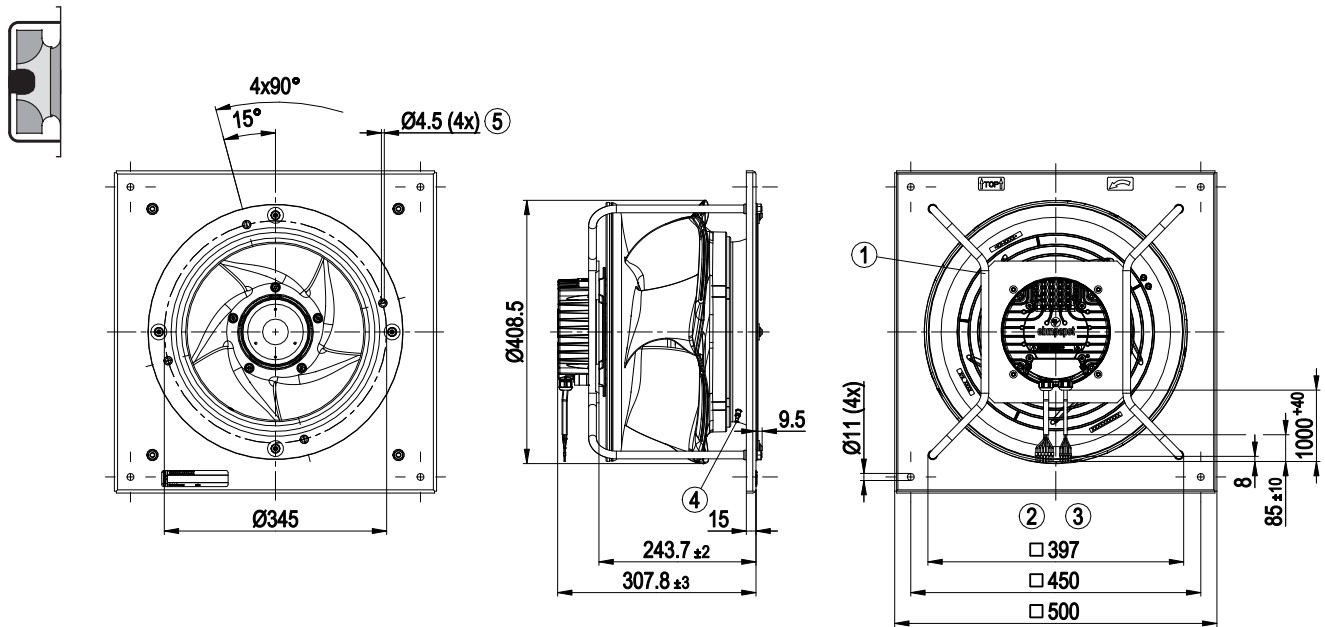

- ① Installed position: shaft horizontal (install support struts only vertically as illustrated) or rotor on bottom; rotor on top on request
- ② Cable PVC AWG18, 6x wire-end ferrule
- ③ Cable PVC AWG22
- ④ Inlet ring with pressure tap (k-factor: 190)
- ⑤ Fastening holes for FlowGrid 00400-2-2957 (not included in scope of delivery) are provided and must be subsequently opened as required

Pin assignment: See connection diagram  
Mounting position: See legend on product drawing



## B VBS0400CTRHS 8300100480 EC centrifugal fan - RadiPac

Dimensions in mm

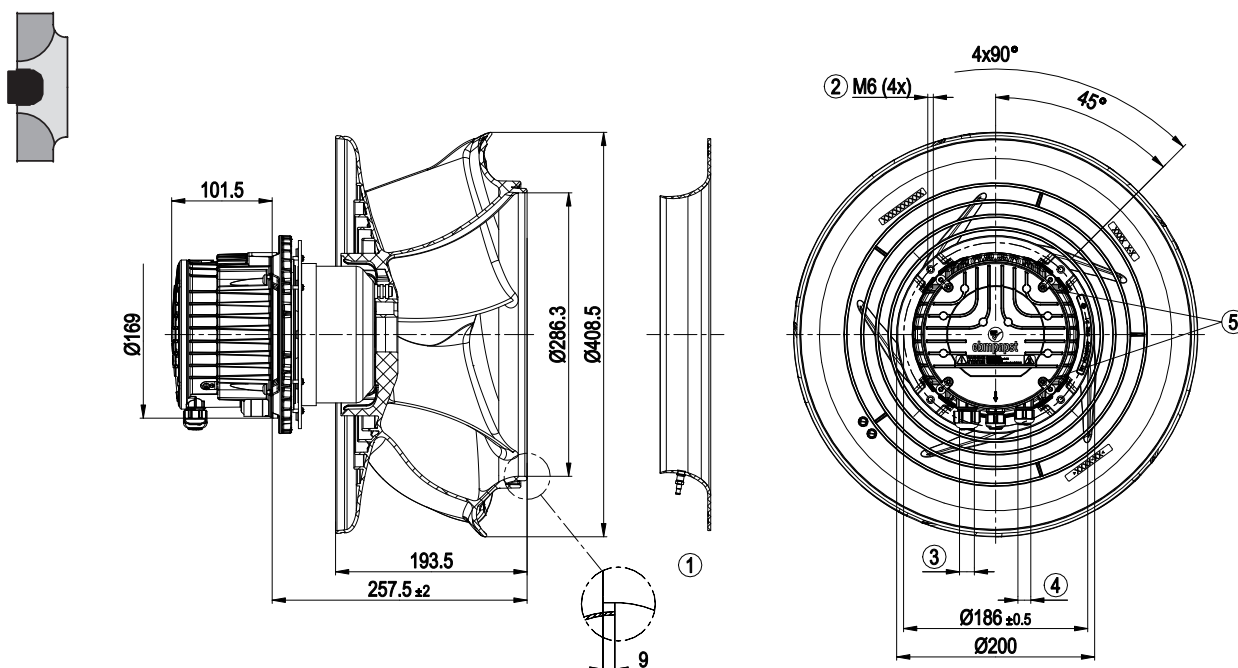

- ① Accessory part: Inlet ring 8217102241 with pressure tap (k-factor: 190) (not included in scope of delivery)
- ② Max. clearance for screw 16 mm
- ③ Cable diameter min. 8 mm, max. 12 mm, tightening torque  $1.8 \pm 0.3$  Nm (use must be made of seal provided); Cable diameter min. 4 mm, max. 10 mm, tightening torque  $1.8 \pm 0.3$  Nm
- ④ Cable diameter min. 6 mm, max. 10 mm, tightening torque  $1.8 \pm 0.3$  Nm (use must be made of seal provided); Cable diameter min. 4 mm, max. 7 mm, tightening torque  $1.8 \pm 0.3$  Nm
- ⑤ Tightening torque  $1.5 \pm 0.2$  Nm

Pin assignment: See connection diagram  
 Mounting position: Shaft horizontal or rotor on bottom; rotor on top on request

## B VBH0400CTRHS 8300100479 EC centrifugal module - RadiPac

Dimensions in mm

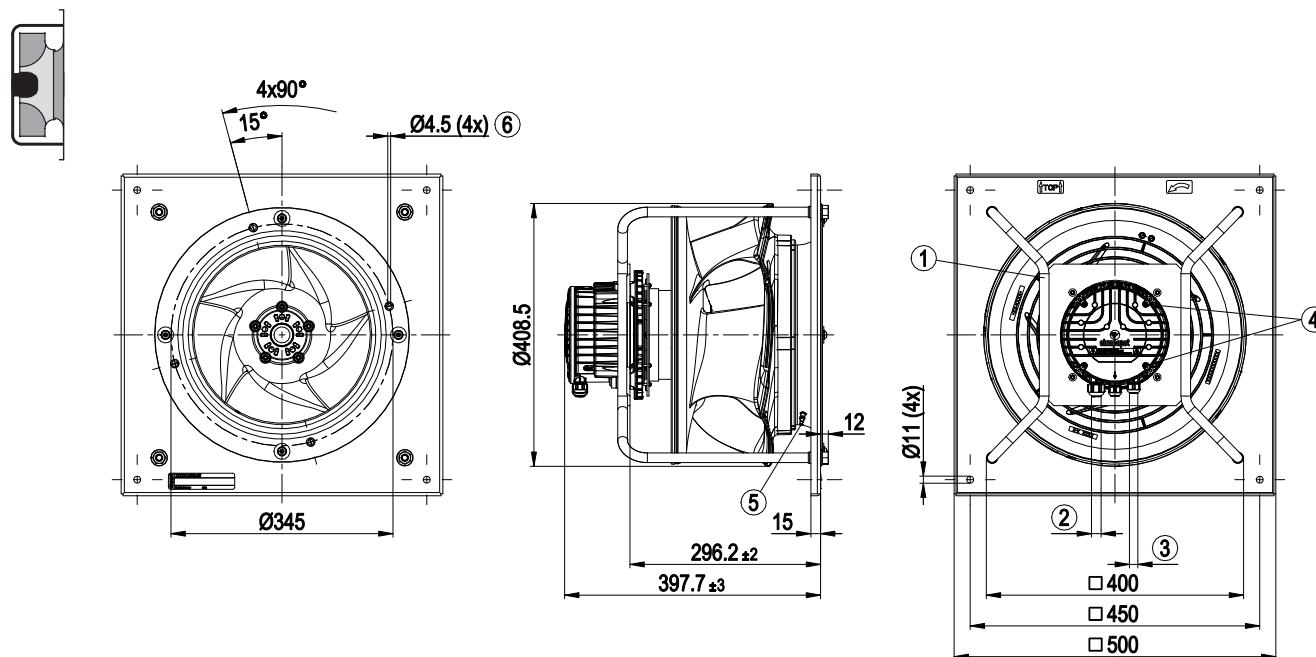

- ① Installed position: shaft horizontal (install support struts only vertically as illustrated) or rotor on bottom; rotor on top on request
- ② Cable diameter min. 8 mm, max. 12 mm, tightening torque  $1.8 \pm 0.3$  Nm (use must be made of seal provided); Cable diameter min. 4 mm, max. 10 mm, tightening torque  $1.8 \pm 0.3$  Nm
- ③ Cable diameter min. 6 mm, max. 10 mm, tightening torque  $1.8 \pm 0.3$  Nm (use must be made of seal provided); Cable diameter min. 4 mm, max. 7 mm, tightening torque  $1.8 \pm 0.3$  Nm
- ④ Tightening torque  $1.5 \pm 0.2$  Nm
- ⑤ Inlet ring with pressure tap (k-factor: 190)
- ⑥ Fastening holes for FlowGrid 00400-2-2957 (not included in scope of delivery) are provided and must be subsequently opened as required

Pin assignment: See connection diagram  
 Mounting position: See legend on product drawing

# RadiPac 400

**C** VBS0400CTRHS 8300100055 EC centrifugal fan - RadiPac

Dimensions in mm

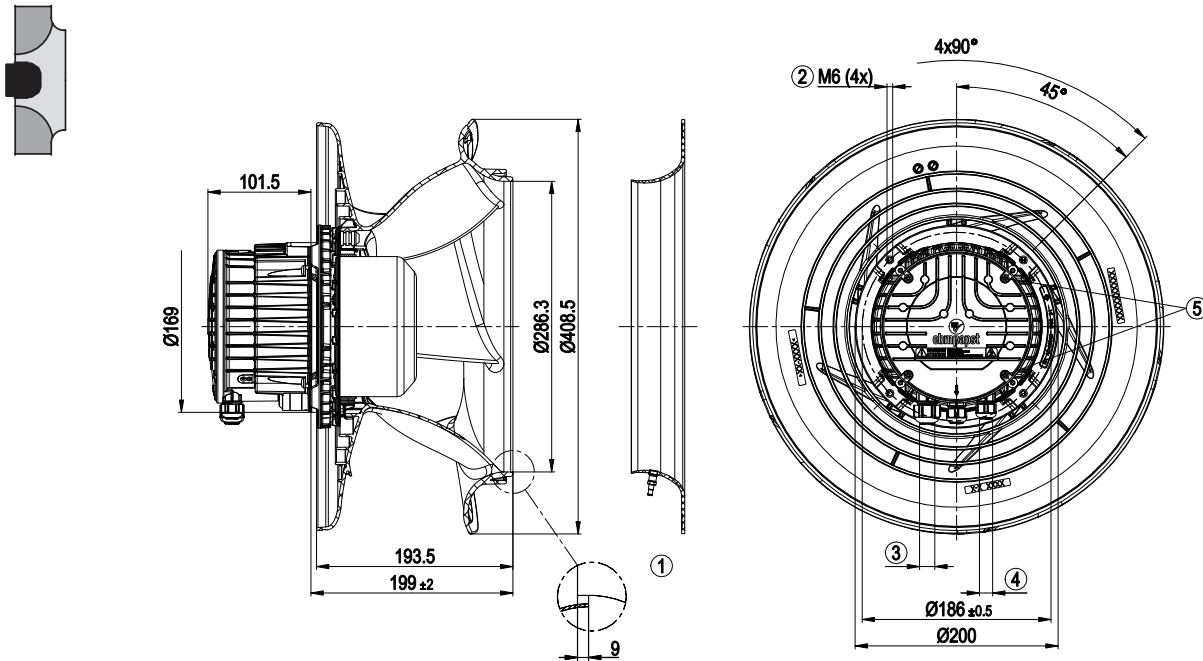

- ① Accessory part: Inlet ring 8217102241 with pressure tap (k-factor: 190) (not included in scope of delivery)
- ② Max. clearance for screw 16 mm
- ③ Cable diameter min. 8 mm, max. 12 mm, tightening torque 1.8±0.3 Nm (use must be made of seal provided); Cable diameter min. 4 mm, max. 10 mm, tightening torque 1.8±0.3 Nm
- ④ Cable diameter min. 6 mm, max. 10 mm, tightening torque 1.8±0.3 Nm (use must be made of seal provided); Cable diameter min. 4 mm, max. 7 mm, tightening torque 1.8±0.3 Nm
- ⑤ Tightening torque 1.5 ± 0.2 Nm

Pin assignment: See connection diagram  
Mounting position: Shaft horizontal or rotor on bottom; rotor on top on request

**C** VBH0400CTRHS 8300100056 EC centrifugal module - RadiPac

Dimensions in mm

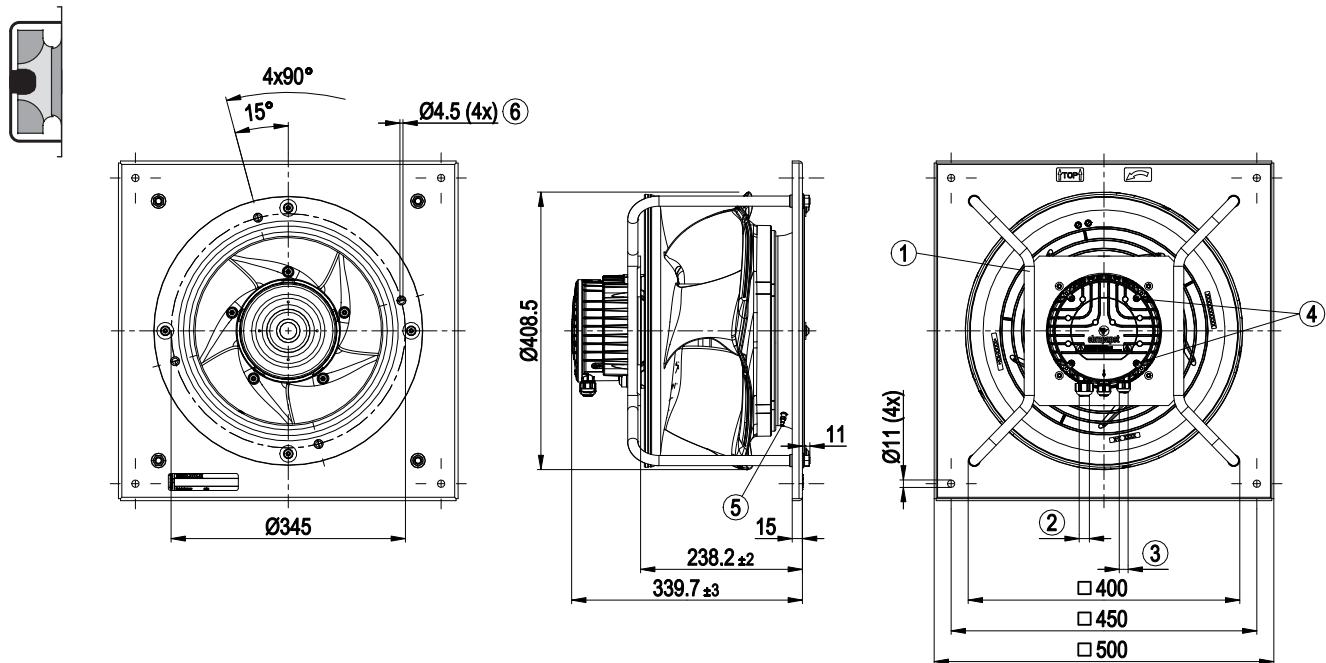

- ① Installed position: shaft horizontal (install support struts only vertically as illustrated) or rotor on bottom; rotor on top on request
- ② Cable diameter min. 8 mm, max. 12 mm, tightening torque 1.8±0.3 Nm (use must be made of seal provided); Cable diameter min. 4 mm, max. 10 mm, tightening torque 1.8±0.3 Nm
- ③ Cable diameter min. 6 mm, max. 10 mm, tightening torque 1.8±0.3 Nm (use must be made of seal provided); Cable diameter min. 4 mm, max. 7 mm, tightening torque 1.8±0.3 Nm
- ④ Tightening torque 1.5 ± 0.2 Nm
- ⑤ Inlet ring with pressure tap (k-factor: 190)
- ⑥ Fastening holes for FlowGrid 00400-2-2957 (not included in scope of delivery) are provided and must be subsequently opened as required

Pin assignment: See connection diagram  
Mounting position: See legend on product drawing

## D VBS0400CTRNS 8300100077 EC centrifugal fan - RadiPac

Dimensions in mm

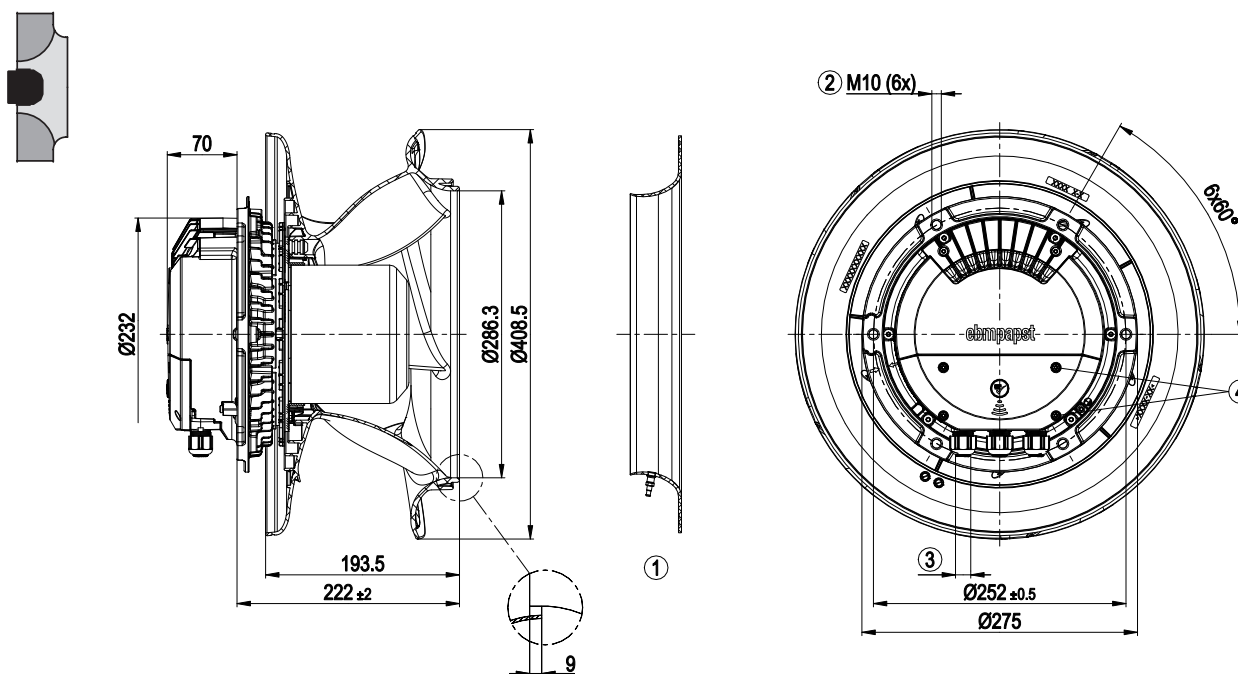

- ① Accessory part: Inlet ring 8217102241 with pressure tap (k-factor: 190) (not included in scope of delivery)
- ② Max. clearance for screw 20 mm
- ③ Cable diameter min. 4 mm, max. 10 mm, tightening torque  $4 \pm 0.6$  Nm  
(The tightening torque is designed for PVC cables. If the cable materials are different, the tightening torque may have to be adjusted)
- ④ Tightening torque  $1.5 \pm 0.2$  Nm

Pin assignment: See connection diagram  
Mounting position: Shaft horizontal or rotor on bottom; rotor on top on request

## D VBH0400CTRNS 8300100078 EC centrifugal module - RadiPac

Dimensions in mm

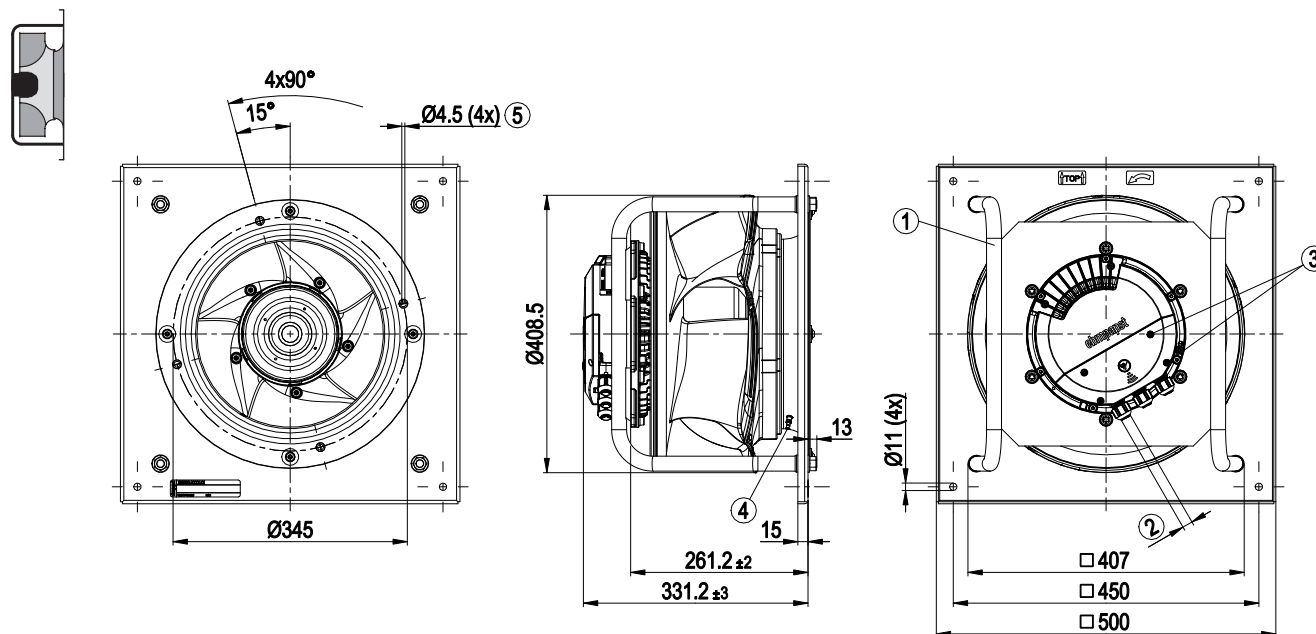

- ① Installed position: shaft horizontal (install support struts only vertically as illustrated) or rotor on bottom; rotor on top on request
- ② Cable diameter min. 4 mm, max. 10 mm, tightening torque  $4 \pm 0.6$  Nm  
(The tightening torque is designed for PVC cables. If the cable materials are different, the tightening torque may have to be adjusted)
- ③ Tightening torque  $1.5 \pm 0.2$  Nm
- ④ Inlet ring with pressure tap (k-factor: 190)
- ⑤ Fastening holes for FlowGrid 00400-2-2957 (not included in scope of delivery) are provided and must be subsequently opened as required

Pin assignment: See connection diagram  
Mounting position: See legend on product drawing

# RadiPac 400

**E** VBS0400CTRNS 8300100059 EC centrifugal fan - RadiPac

Dimensions in mm

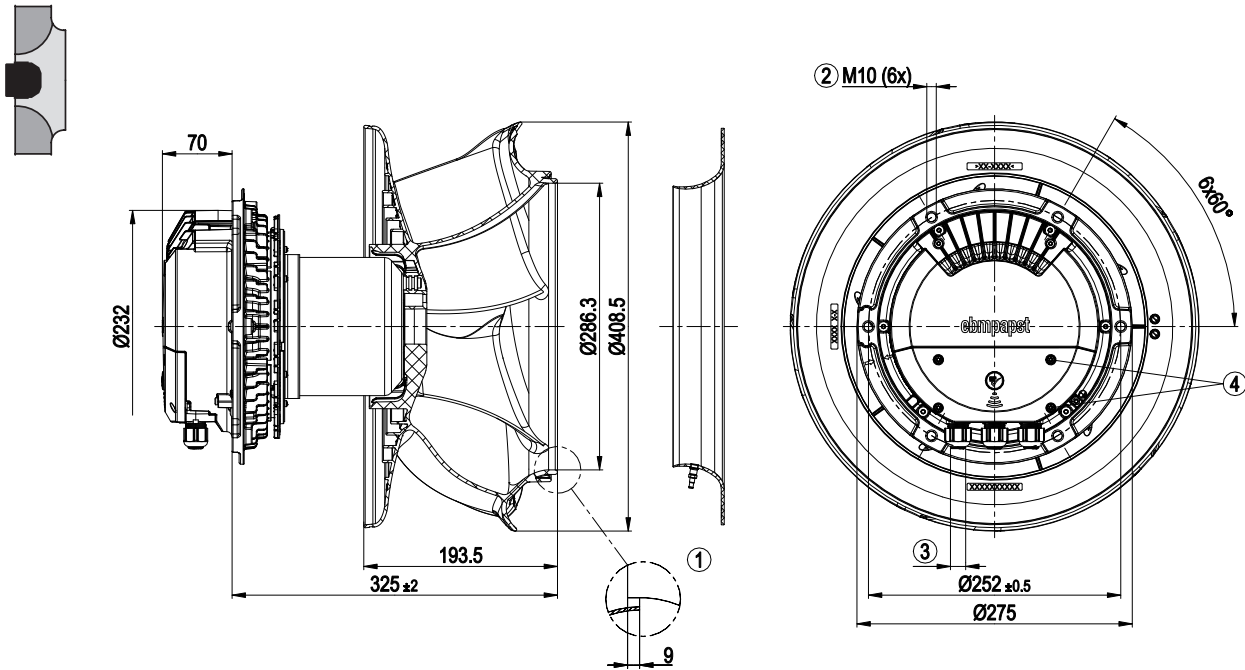

- ① Accessory part: Inlet ring 8217102241 with pressure tap (k-factor: 190) (not included in scope of delivery)
- ② Max. clearance for screw 20 mm
- ③ Cable diameter min. 4 mm, max. 10 mm, tightening torque  $4 \pm 0.6$  Nm  
(The tightening torque is designed for PVC cables. If the cable materials are different, the tightening torque may have to be adjusted)
- ④ Tightening torque  $1.5 \pm 0.2$  Nm

Pin assignment: See connection diagram  
Mounting position: Shaft horizontal or rotor on bottom; rotor on top on request

**E** VBH0400CTRNS 8300100058 EC centrifugal module - RadiPac

Dimensions in mm

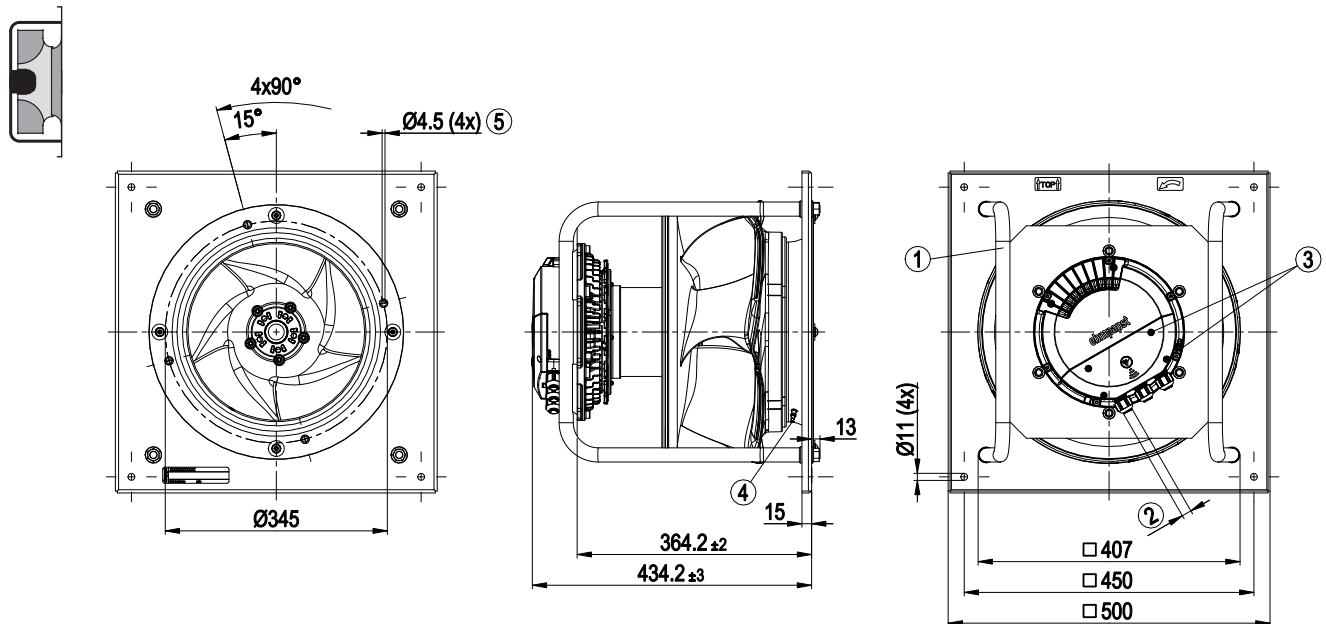

- ① Installed position: shaft horizontal (install support struts only vertically as illustrated) or rotor on bottom; rotor on top on request
- ② Cable diameter min. 4 mm, max. 10 mm, tightening torque  $4 \pm 0.6$  Nm  
(The tightening torque is designed for PVC cables. If the cable materials are different, the tightening torque may have to be adjusted)
- ③ Tightening torque  $1.5 \pm 0.2$  Nm
- ④ Inlet ring with pressure tap (k-factor: 190)
- ⑤ Fastening holes for FlowGrid 00400-2-2957 (not included in scope of delivery) are provided and must be subsequently opened as required

Pin assignment: See connection diagram  
Mounting position: See legend on product drawing

## F VBS0400CTTLS 8300100127 EC centrifugal fan - RadiPac

Dimensions in mm

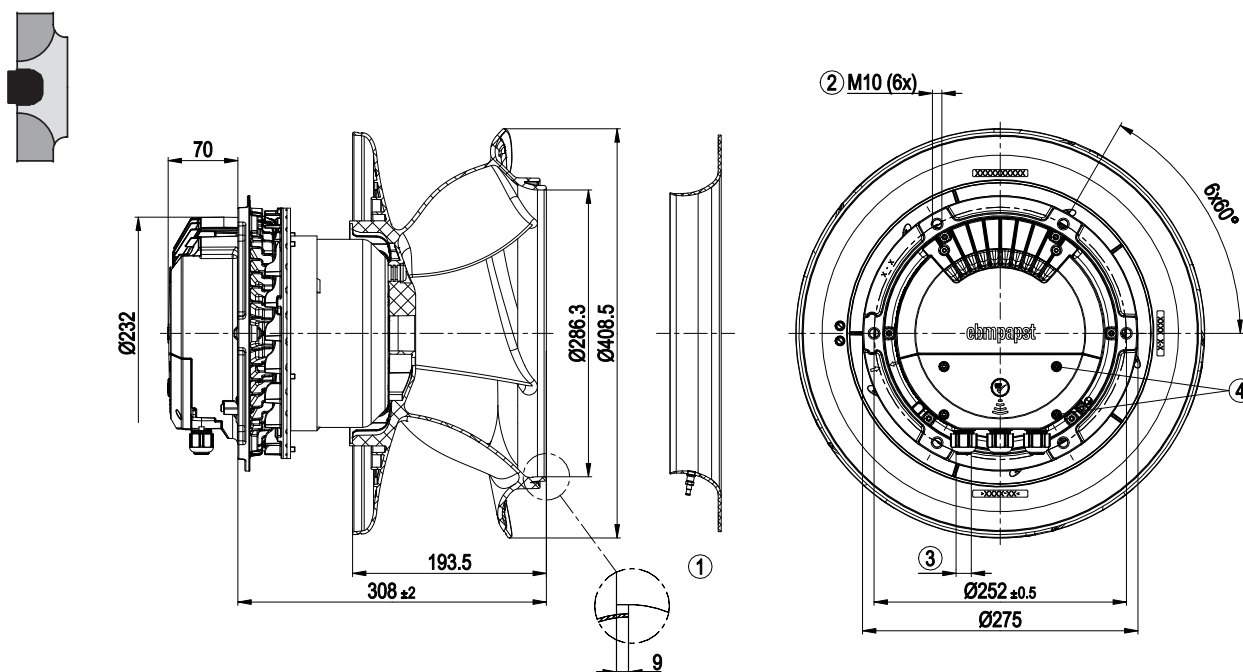

- ① Accessory part: Inlet ring 8217102241 with pressure tap (k-factor: 190) (not included in scope of delivery)
- ② Max. clearance for screw 20 mm
- ③ Cable diameter min. 4 mm, max. 10 mm, tightening torque  $4 \pm 0.6$  Nm  
(The tightening torque is designed for PVC cables. If the cable materials are different, the tightening torque may have to be adjusted)
- ④ Tightening torque  $1.5 \pm 0.2$  Nm

Pin assignment: See connection diagram  
Mounting position: Shaft horizontal or rotor on bottom; rotor on top on request

## F VBH0400CTTLS 8300100128 EC centrifugal module - RadiPac

Dimensions in mm

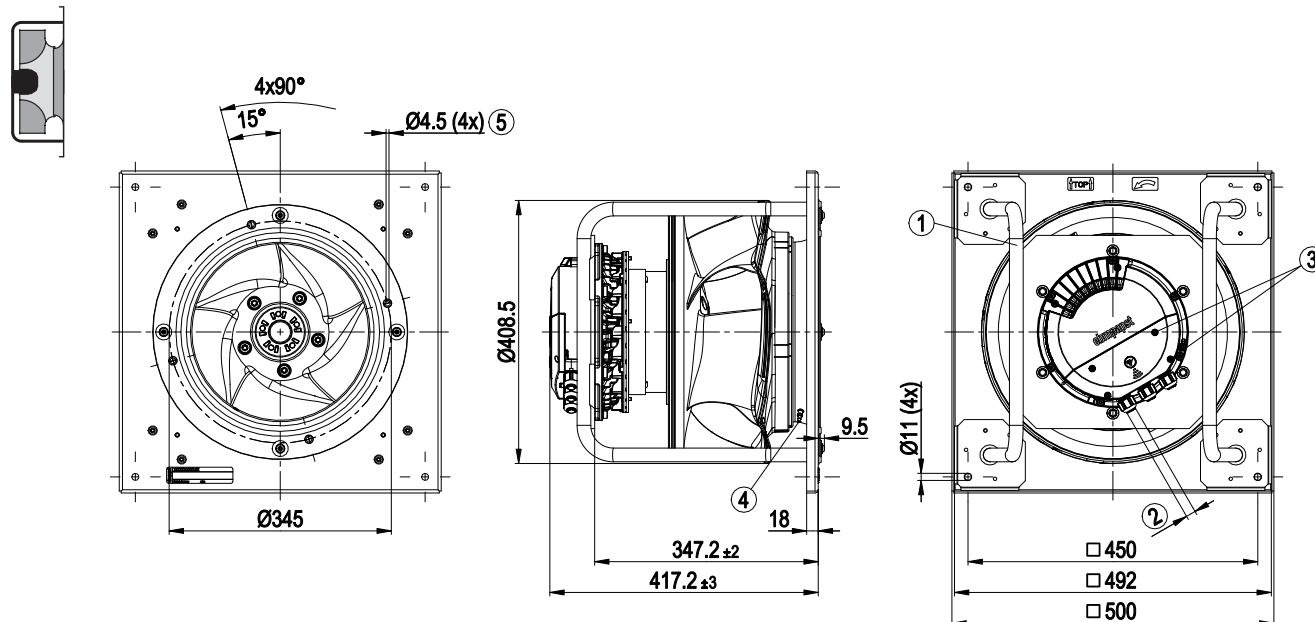

- ① Installed position: shaft horizontal (install support struts only vertically as illustrated) or rotor on bottom; rotor on top on request
- ② Cable diameter min. 4 mm, max. 10 mm, tightening torque  $4 \pm 0.6$  Nm  
(The tightening torque is designed for PVC cables. If the cable materials are different, the tightening torque may have to be adjusted)
- ③ Tightening torque  $1.5 \pm 0.2$  Nm
- ④ Inlet ring with pressure tap (k-factor: 190)
- ⑤ Fastening holes for FlowGrid 00400-2-2957 (not included in scope of delivery) are provided and must be subsequently opened as required

Pin assignment: See connection diagram  
Mounting position: See legend on product drawing

# RadiPac 450

EC centrifugal fans, backward curved



## Material/Surface

- Support bracket: Steel, painted black
- Support plate: Sheet steel, galvanized
- Inlet nozzle: ABS plastic
- Impeller: PP plastic
- Rotor: Painted black
- Electronics housing: Die-cast aluminum

## Mechanical characteristics

- Number of blades: 5
- Drehrichtung (epM): Clockwise, viewed toward rotor
- Installation position: Shaft horizontal or rotor on bottom; rotor on top on request, See legend on product drawing
- Condensation drainage holes: On rotor side
- Mode: S1
- Motor bearing: Ball bearing

## Additional Information

- Information about touch current, electrical connection, degree of protection, insulation class, environmental protection class, EMC standards as well as standards and approvals can be found in the product-specific data sheets.

from page 56	Drawings
from page 92	Accessories
from page 102	Connection diagrams and technical equipment
from page 110	Environment and general conditions
More at	<a href="http://www.ebmpapst.com/worldwide">www.ebmpapst.com/worldwide</a> <a href="http://www.ebmpapst.com/">www.ebmpapst.com/</a>

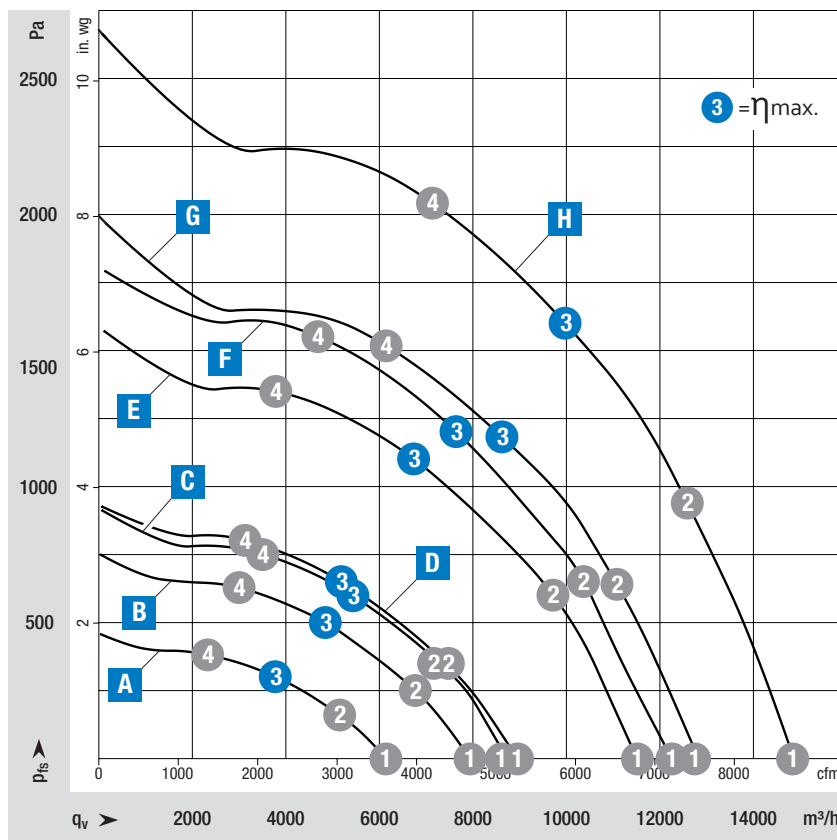

















### Measuring conditions

Air performance measured after: ISO 5801, installation category A, with ebm-papst inlet nozzle without contact protection.

Suction-side noise level: L<sub>WA</sub> according to ISO 13347, L<sub>pA</sub> measured at a distance of 1 m on the fan axis.

The specifications apply only under the specified measuring conditions and may change due to installation conditions.

In case of deviations from the standard design, the characteristic values must be checked in the installed condition!

Nominal voltage range 1- 200-277 VAC, 50/60 Hz			Characteristic Curve	Operating point	Nominal voltage	Speed n	Max. Input power P <sub>ed</sub>	Max. Input current I	Sound power level L <sub>WA</sub>	Max. back pressure Pa	Perm. ambient temp. °C	Protection class	Connection diagrams and technical equipment
Type	Part number	Fan type			V	rpm	W	A	dB(A)	Pa	°C		
VBS0450CSPKS	8300100444	Centrifugal fan	 Short-version	A	① 230	1,440	339	1.50	78	---	-25...+40	IP55	Page 105
					② 230	1,440	438	1.92	72				
					③ 230	1,440	500	2.20	67				
					④ 230	1,440	469	2.05	68				
VBH0450CSPKS	8300100445	Support bracket	 Short-version										
Nominal voltage range 3- 380-480 VAC, 50/60 Hz					V	rpm	W	A	dB(A)	Pa	°C		
Type	Part number	Fan type			V	rpm	W	A	dB(A)	Pa	°C		
VBS0450CTPMS	8300100405	Centrifugal fan	 Short-version	B	① 400	1,860	705	1.11	84	---	-40...+40	IP55	Page 103
					② 400	1,860	919	1.43	78				
					③ 400	1,860	1,070	1.70	73				
					④ 400	1,860	991	1.53	75				
VBH0450CTPMS	8300100406	Support bracket	 Short-version										
VBS0450CTRLS	8300100549	Centrifugal fan	 Short-version	C	① 400	2,110	1,003	1.55	87	---	-40...+40	IP55	Page 103
					② 400	2,110	1,246	1.91	81				
					③ 400	2,110	1,430	2.20	76				
					④ 400	2,110	1,297	1.99	80				
VBH0450CTRLS	8300100550	Support bracket	 Short-version										
VBS0450CTRLS	8300100503	Centrifugal fan	 Long-version	D	① 400	2,040	878	1.36	86	---	-40...+40	IP55	Page 103
					② 400	2,040	1,159	1.78	80				
					③ 400	2,040	1,300	2.00	74				
					④ 400	2,040	1,240	1.90	76				
VBH0450CTRLS	8300100502	Support bracket	 Long-version										
VBS0450CTRNS	8300100312	Centrifugal fan	 Short-version	E	① 400	2,940	2,783	4.28	96	---	-40...+40	IP55	Page 102
					② 400	2,940	3,534	5.40	89				
					③ 400	2,940	3,850	5.90	85				
					④ 400	2,940	3,586	5.48	89				
VBH0450CTRNS	8300100311	Support bracket	 Short-version										
VBS0450CTRNS	8300100345	Centrifugal fan	 Long-version	F	① 400	2,690	1,983	3.10	93	---	-40...+40	IP55	Page 102
					② 400	2,690	2,663	4.11	87				
					③ 400	2,690	3,050	4.70	81				
					④ 400	2,690	2,601	4.01	87				
VBH0450CTRNS	8300100344	Support bracket	 Long-version										
VBS0450CTTLS	8300100038	Centrifugal fan	 Long-version	G	① 400	2,960	2,690	4.22	99	---	-40...+40	IP55	Page 102
					② 400	2,960	3,660	5.62	94				
					③ 400	2,960	4,050	6.20	89				
					④ 400	2,960	3,995	6.13	85				
VBH0450CTTLS	8300100043	Support bracket	 Long-version										
VBS0450CTTPS	8300100076	Centrifugal fan	 Long-version	H	① 400	3,430	4,230	6.94	101	---	-40...+40	IP55	Page 102
					② 400	3,430	5,835	9.23	95				
					③ 400	3,430	6,300	9.90	92				
					④ 400	3,430	6,170	9.69	91				
VBH0450CTTPS	8300100075	Support bracket	 Long-version										

Subject to changes.

Values set in blue are nominal data at the operating point at maximum load.

# RadiPac 450

**A** VBS0450CSPKS 8300100444 EC centrifugal fan - RadiPac

Dimensions in mm

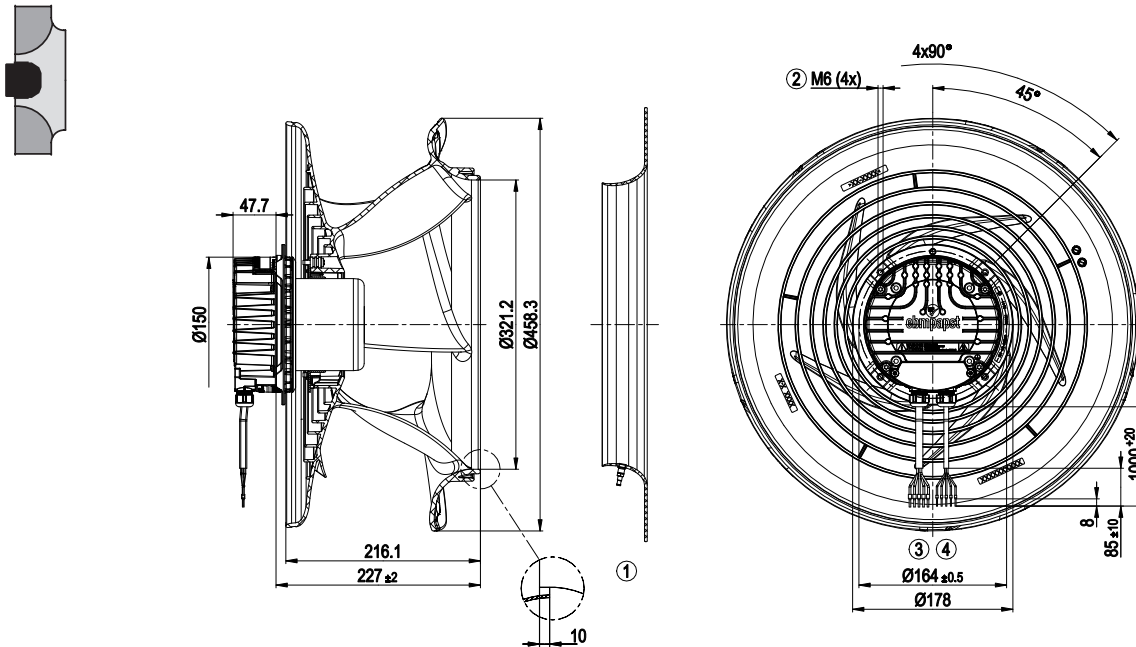

- ① Accessory part: Inlet ring 8217102239 with pressure tap (k-factor: 232) (not included in scope of delivery)
- ② Max. clearance for screw 16 mm
- ③ Cable PVC AWG18, 5x wire-end ferrule
- ④ Cable PVC AWG22

Pin assignment: See connection diagram  
 Mounting position: Shaft horizontal or rotor on bottom; rotor on top on request

**A** VBH0450CSPKS 8300100445 EC centrifugal module - RadiPac

Dimensions in mm

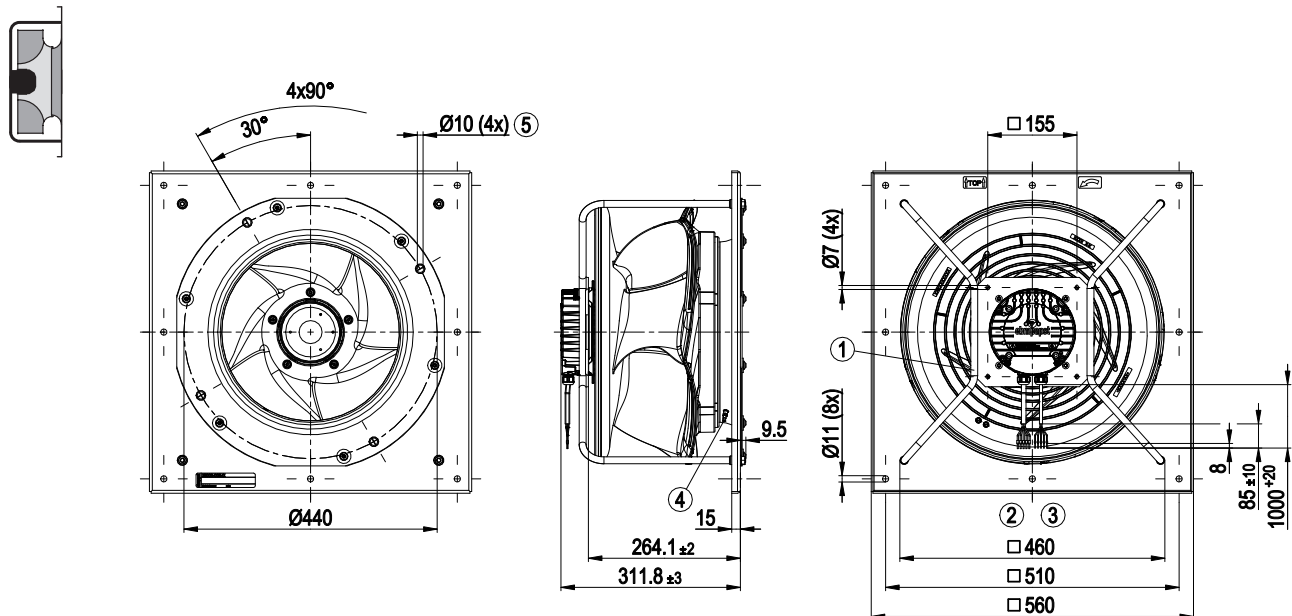

- ① Installed position: shaft horizontal (install support struts only vertically as illustrated) or rotor on bottom; rotor on top on request
- ② Cable PVC AWG18, 5x wire-end ferrule
- ③ Cable PVC AWG22
- ④ Inlet ring with pressure tap (k-factor: 232)
- ⑤ Fastening holes for FlowGrid 35505-2-2957 (not included in scope of delivery) are provided and must be subsequently opened as required

Pin assignment: See connection diagram  
 Mounting position: See legend on product drawing



## B VBS0450CTPMS 8300100405 EC centrifugal fan - RadiPac

Dimensions in mm

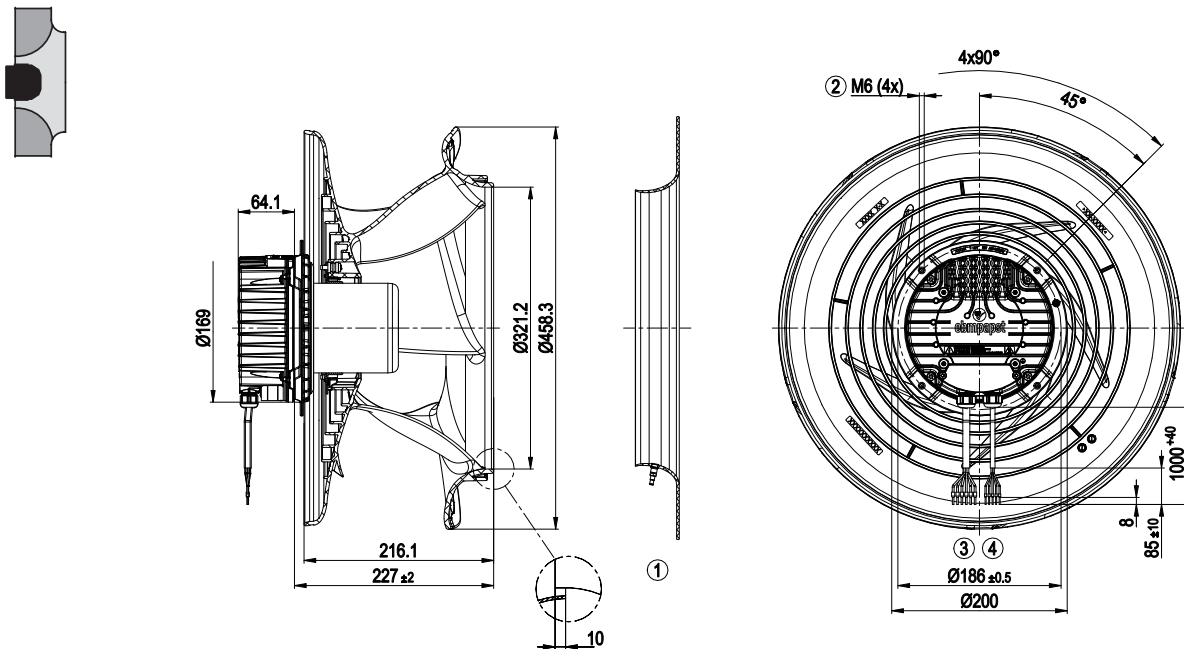

- ① Accessory part: Inlet ring 8217102239 with pressure tap (k-factor: 232) (not included in scope of delivery)
- ② Max. clearance for screw 16 mm
- ③ Cable PVC AWG18, 6x wire-end ferrule
- ④ Cable PVC AWG22

Pin assignment: See connection diagram  
 Mounting position: Shaft horizontal or rotor on bottom; rotor on top on request

## B VBH0450CTPMS 8300100406 EC centrifugal module - RadiPac

Dimensions in mm

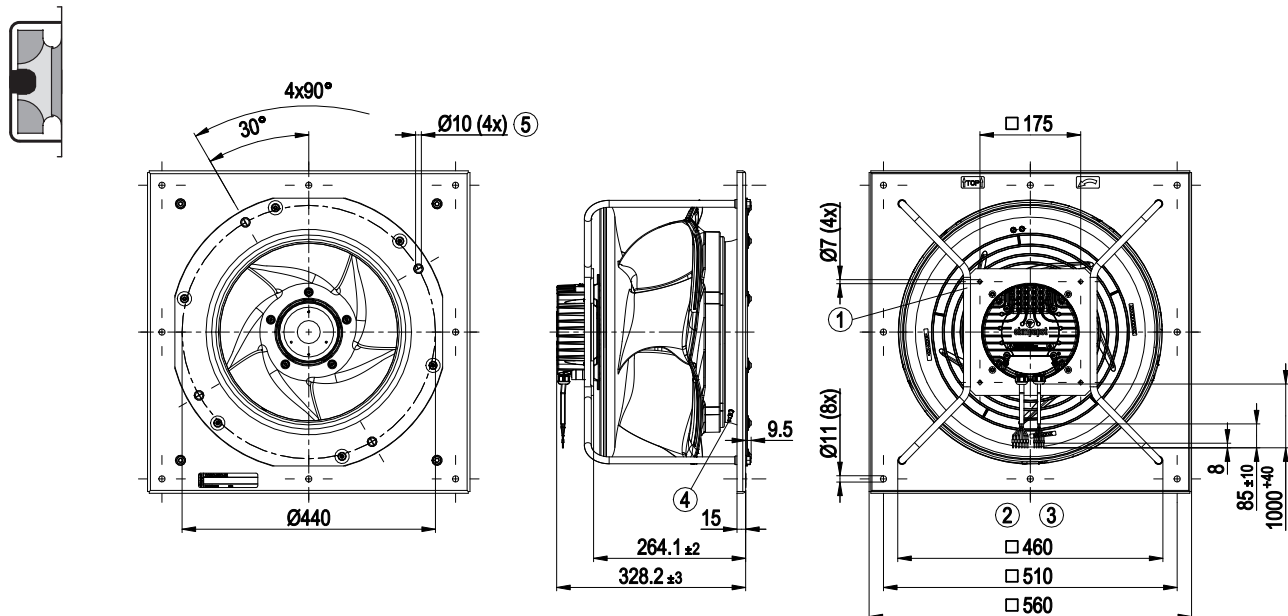

- ① Installed position: shaft horizontal (install support struts only vertically as illustrated) or rotor on bottom; rotor on top on request
- ② Cable PVC AWG18, 6x wire-end ferrule
- ③ Cable PVC AWG22
- ④ Inlet ring with pressure tap (k-factor: 232)
- ⑤ Fastening holes for FlowGrid 00400-2-2957 (not included in scope of delivery) are provided and must be subsequently opened as required

Pin assignment: See connection diagram  
 Mounting position: See legend on product drawing

# RadiPac 450

**C** VBS0450CTRLS 8300100549 EC centrifugal fan - RadiPac

Dimensions in mm

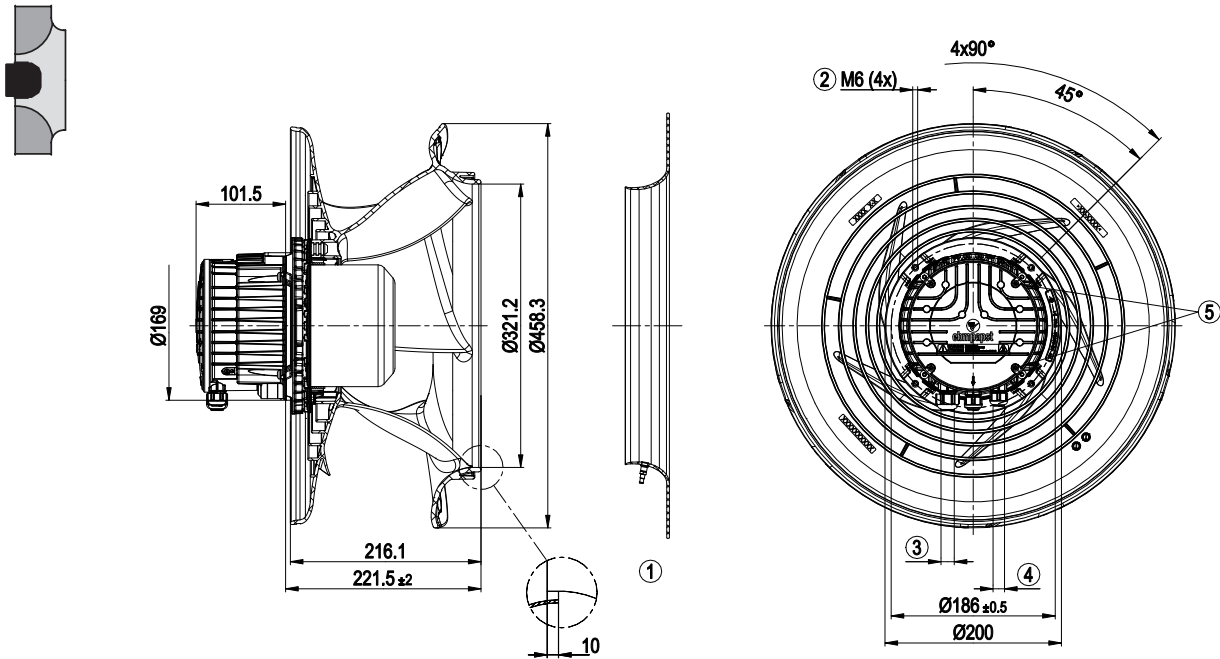

- ① Accessory part: Inlet ring 8217102239 with pressure tap (k-factor: 232) (not included in scope of delivery)
- ② Max. clearance for screw 16 mm
- ③ Cable diameter min. 8 mm, max. 12 mm, tightening torque  $1.8 \pm 0.3$  Nm (use must be made of seal provided); Cable diameter min. 4 mm, max. 10 mm, tightening torque  $1.8 \pm 0.3$  Nm
- ④ Cable diameter min. 6 mm, max. 10 mm, tightening torque  $1.8 \pm 0.3$  Nm (use must be made of seal provided); Cable diameter min. 4 mm, max. 7 mm, tightening torque  $1.8 \pm 0.3$  Nm
- ⑤ Tightening torque  $1.5 \pm 0.2$  Nm

Pin assignment: See connection diagram  
Mounting position: Shaft horizontal or rotor on bottom; rotor on top on request

**C** VBH0450CTRLS 8300100550 EC centrifugal module - RadiPac

Dimensions in mm

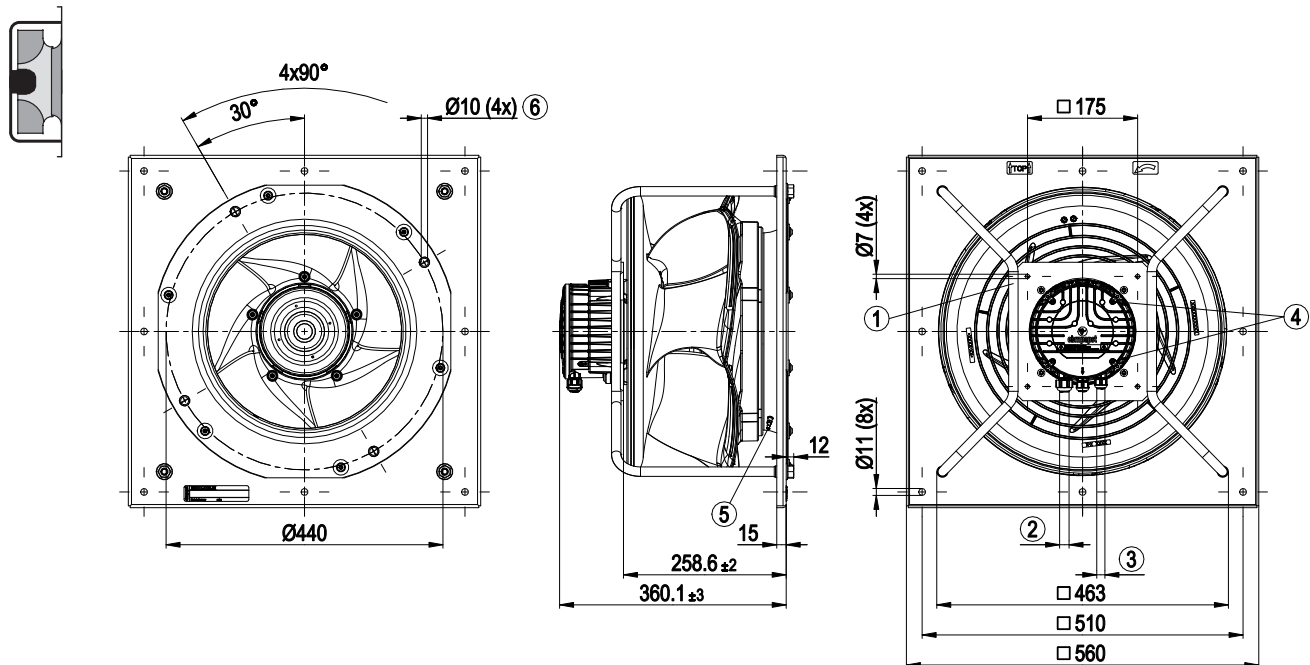

- ① Installed position: shaft horizontal (install support struts only vertically as illustrated) or rotor on bottom; rotor on top on request
- ② Cable diameter min. 8 mm, max. 12 mm, tightening torque  $1.8 \pm 0.3$  Nm (use must be made of seal provided); Cable diameter min. 4 mm, max. 10 mm, tightening torque  $1.8 \pm 0.3$  Nm
- ③ Cable diameter min. 6 mm, max. 10 mm, tightening torque  $1.8 \pm 0.3$  Nm (use must be made of seal provided); Cable diameter min. 4 mm, max. 7 mm, tightening torque  $1.8 \pm 0.3$  Nm
- ④ Tightening torque  $1.5 \pm 0.2$  Nm
- ⑤ Inlet ring with pressure tap (k-factor: 232)
- ⑥ Fastening holes for FlowGrid 35505-2-2957 (not included in scope of delivery) are provided and must be subsequently opened as required

Pin assignment: See connection diagram  
Mounting position: See legend on product drawing

## D VBS0450CTRLS 8300100503 EC centrifugal fan - RadiPac

Dimensions in mm

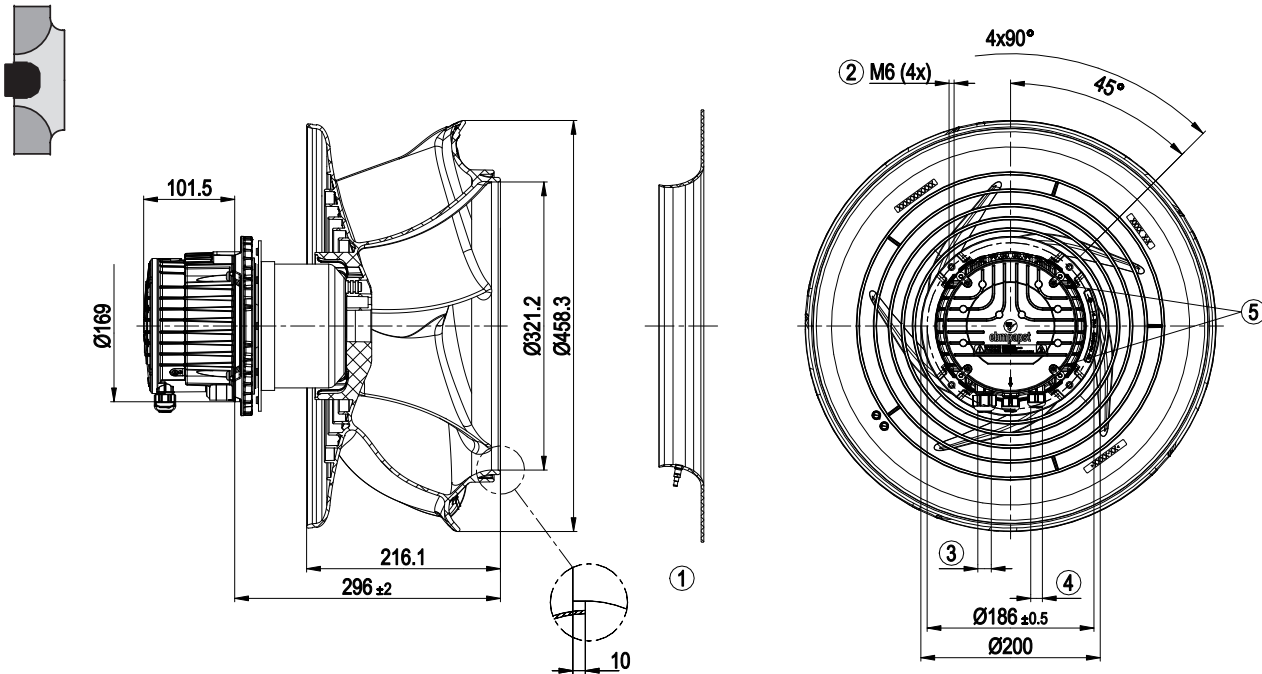

- ① Accessory part: Inlet ring 8217102239 with pressure tap (k-factor: 232) (not included in scope of delivery)
- ② Max. clearance for screw 16 mm
- ③ Cable diameter min. 8 mm, max. 12 mm, tightening torque 1.8±0.3 Nm (use must be made of seal provided); Cable diameter min. 4 mm, max. 10 mm, tightening torque 1.8±0.3 Nm
- ④ Cable diameter min. 6 mm, max. 10 mm, tightening torque 1.8±0.3 Nm (use must be made of seal provided); Cable diameter min. 4 mm, max. 7 mm, tightening torque 1.8±0.3 Nm
- ⑤ Tightening torque 1.5 ± 0.2 Nm

Pin assignment: See connection diagram  
Mounting position: Shaft horizontal or rotor on bottom; rotor on top on request

## D VBH0450CTRLS 8300100502 EC centrifugal module - RadiPac

Dimensions in mm

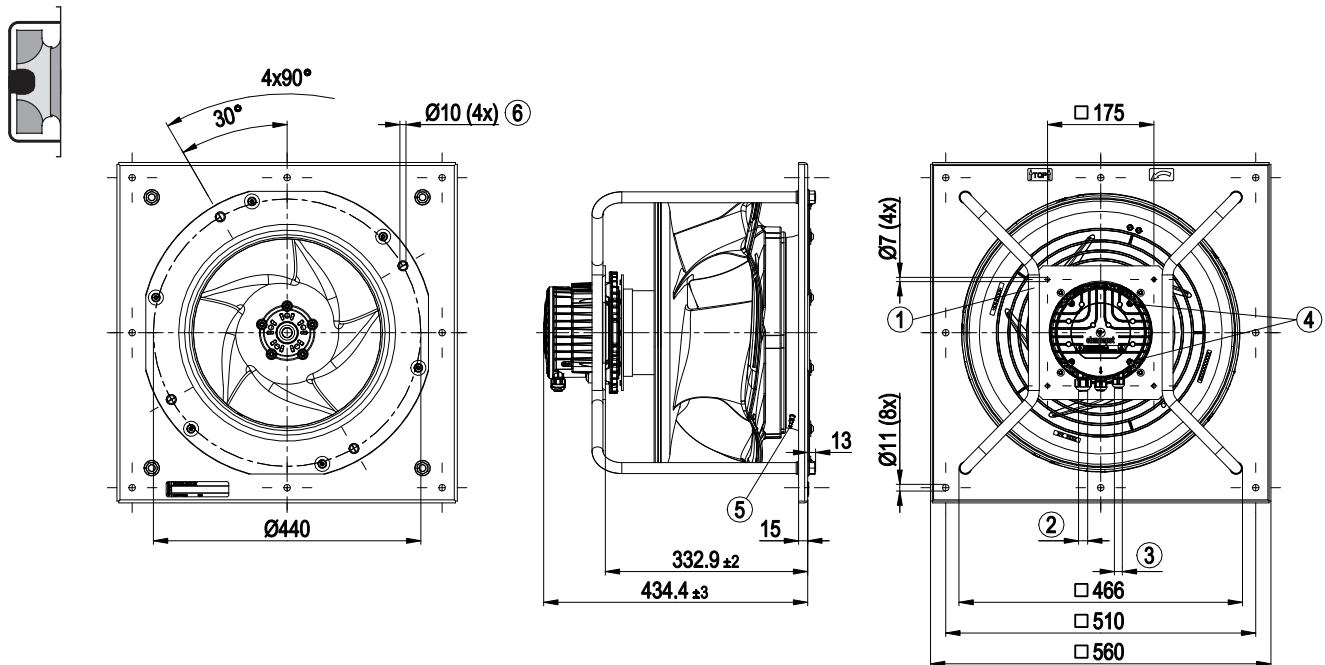

- ① Installed position: shaft horizontal (install support struts only vertically as illustrated) or rotor on bottom; rotor on top on request
- ② Cable diameter min. 8 mm, max. 12 mm, tightening torque 1.8±0.3 Nm (use must be made of seal provided); Cable diameter min. 4 mm, max. 10 mm, tightening torque 1.8±0.3 Nm
- ③ Cable diameter min. 6 mm, max. 10 mm, tightening torque 1.8±0.3 Nm (use must be made of seal provided); Cable diameter min. 4 mm, max. 7 mm, tightening torque 1.8±0.3 Nm
- ④ Tightening torque 1.5 ± 0.2 Nm
- ⑤ Inlet ring with pressure tap (k-factor: 232)
- ⑥ Fastening holes for FlowGrid 35505-2-2957 (not included in scope of delivery) are provided and must be subsequently opened as required

Pin assignment: See connection diagram  
Mounting position: See legend on product drawing

# RadiPac 450

**E** VBS0450CTRNS 8300100312 EC centrifugal fan - RadiPac

Dimensions in mm

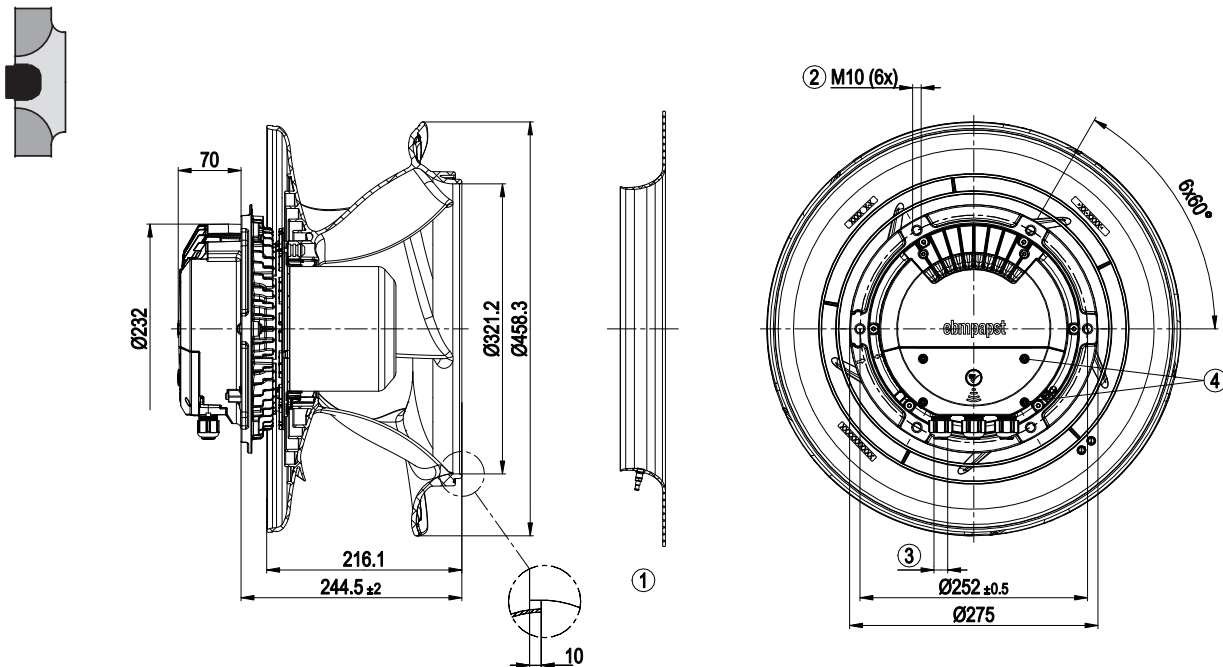

- ① Accessory part: Inlet ring 8217102239 with pressure tap (k-factor: 232) (not included in scope of delivery)
- ② Max. clearance for screw 20 mm
- ③ Cable diameter min. 4 mm, max. 10 mm, tightening torque  $4 \pm 0.6$  Nm  
(The tightening torque is designed for PVC cables. If the cable materials are different, the tightening torque may have to be adjusted)
- ④ Tightening torque  $1.5 \pm 0.2$  Nm

Pin assignment: See connection diagram  
Mounting position: Shaft horizontal or rotor on bottom; rotor on top on request

**E** VBH0450CTRNS 8300100311 EC centrifugal module - RadiPac

Dimensions in mm

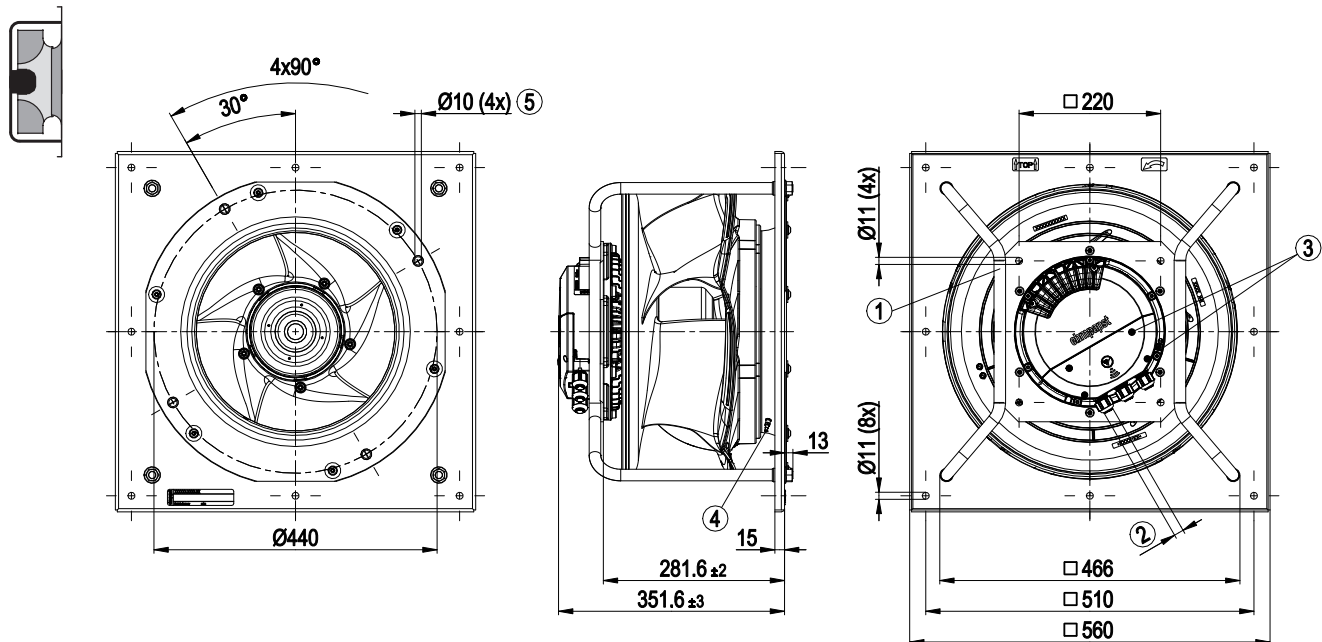

- ① Installed position: shaft horizontal (install support struts only vertically as illustrated) or rotor on bottom; rotor on top on request
- ② Cable diameter min. 4 mm, max. 10 mm, tightening torque  $4 \pm 0.6$  Nm  
(The tightening torque is designed for PVC cables. If the cable materials are different, the tightening torque may have to be adjusted)
- ③ Tightening torque  $1.5 \pm 0.2$  Nm
- ④ Inlet ring with pressure tap (k-factor: 232)
- ⑤ Fastening holes for FlowGrid 35505-2-2957 (not included in scope of delivery) are provided and must be subsequently opened as required

Pin assignment: See connection diagram  
Mounting position: See legend on product drawing

**F** VBS0450CTRNS 8300100345 EC centrifugal fan - RadiPac

Dimensions in mm

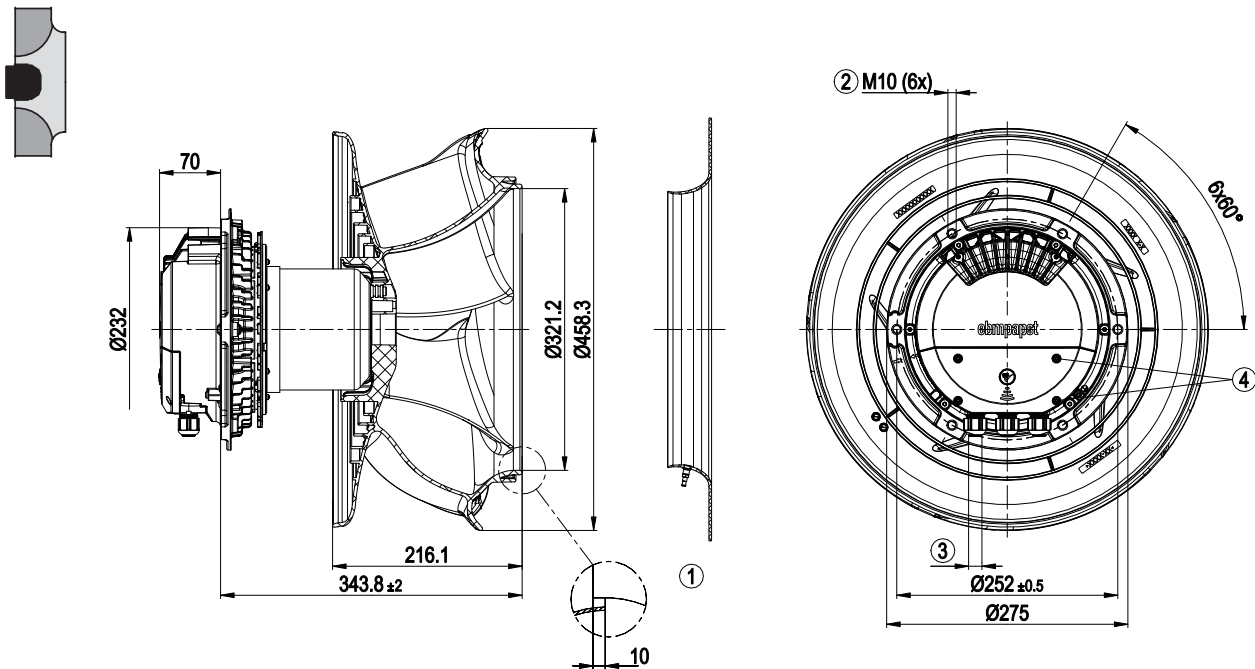

- ① Accessory part: Inlet ring 8217102239 with pressure tap (k-factor: 232) (not included in scope of delivery)
- ② Max. clearance for screw 20 mm
- ③ Cable diameter min. 4 mm, max. 10 mm, tightening torque  $4 \pm 0.6$  Nm  
(The tightening torque is designed for PVC cables. If the cable materials are different, the tightening torque may have to be adjusted)
- ④ Tightening torque  $1.5 \pm 0.2$  Nm

Pin assignment: See connection diagram  
Mounting position: Shaft horizontal or rotor on bottom; rotor on top on request

**F** VBH0450CTRNS 8300100344 EC centrifugal module - RadiPac

Dimensions in mm

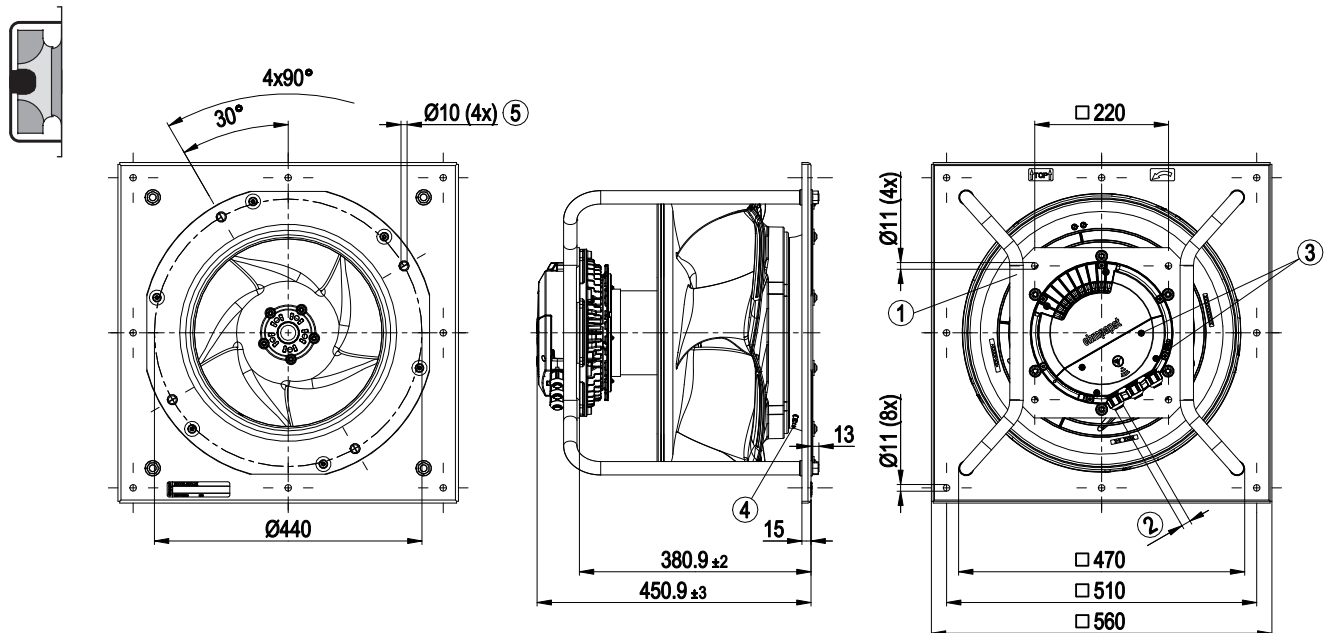

- ① Installed position: shaft horizontal (install support struts only vertically as illustrated) or rotor on bottom; rotor on top on request
- ② Cable diameter min. 4 mm, max. 10 mm, tightening torque  $4 \pm 0.6$  Nm  
(The tightening torque is designed for PVC cables. If the cable materials are different, the tightening torque may have to be adjusted)
- ③ Tightening torque  $1.5 \pm 0.2$  Nm
- ④ Inlet ring with pressure tap (k-factor: 232)
- ⑤ Fastening holes for FlowGrid 35505-2-2957 (not included in scope of delivery) are provided and must be subsequently opened as required

Pin assignment: See connection diagram  
Mounting position: See legend on product drawing

# RadiPac 450

G VBS0450CTTLS 8300100038 EC centrifugal fan - RadiPac

Dimensions in mm

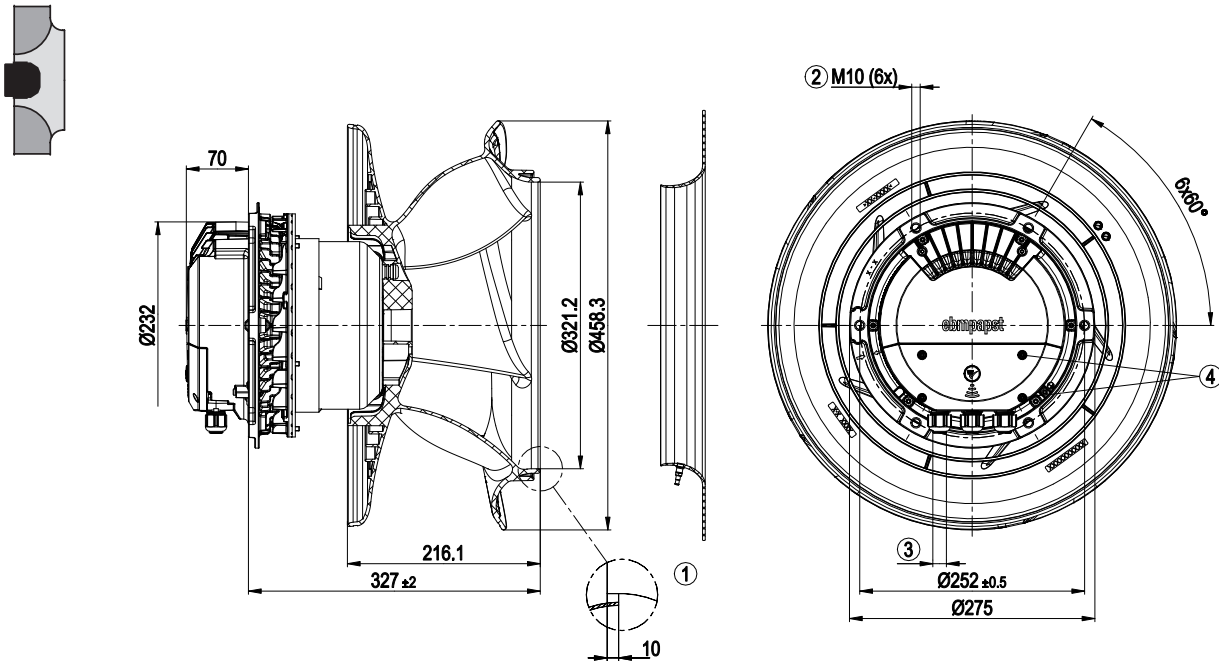

- ① Accessory part: Inlet ring 8217102239 with pressure tap (k-factor: 232) (not included in scope of delivery)
- ② Max. clearance for screw 20 mm
- ③ Cable diameter min. 4 mm, max. 10 mm, tightening torque  $4 \pm 0.6$  Nm  
(The tightening torque is designed for PVC cables. If the cable materials are different, the tightening torque may have to be adjusted)
- ④ Tightening torque  $1.5 \pm 0.2$  Nm

Pin assignment: See connection diagram  
Mounting position: Shaft horizontal or rotor on bottom; rotor on top on request

G VBH0450CTTLS 8300100043 EC centrifugal module - RadiPac

Dimensions in mm

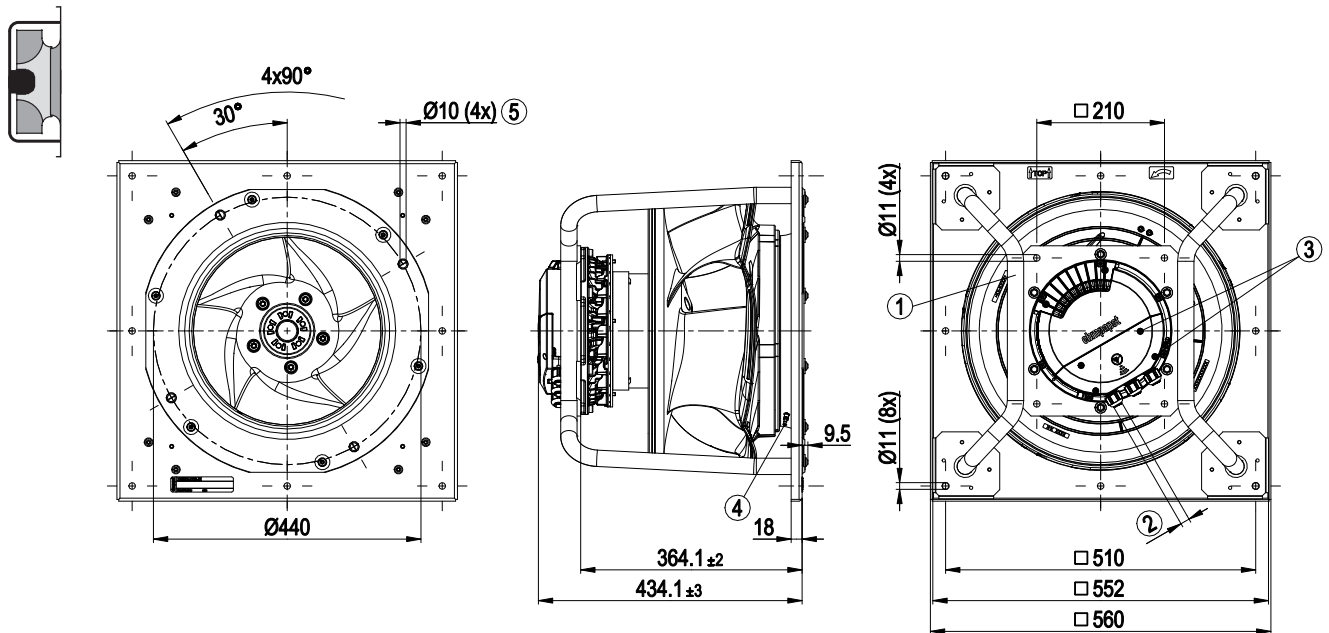

- ① Installed position: shaft horizontal (install support struts only vertically as illustrated) or rotor on bottom; rotor on top on request
- ② Cable diameter min. 4 mm, max. 10 mm, tightening torque  $4 \pm 0.6$  Nm  
(The tightening torque is designed for PVC cables. If the cable materials are different, the tightening torque may have to be adjusted)
- ③ Tightening torque  $1.5 \pm 0.2$  Nm
- ④ Inlet ring with pressure tap (k-factor: 232)
- ⑤ Fastening holes for FlowGrid 35505-2-2957 (not included in scope of delivery) are provided and must be subsequently opened as required

Pin assignment: See connection diagram  
Mounting position: See legend on product drawing

## H VBS0450CTTPS 8300100076 EC centrifugal fan - RadiPac

Dimensions in mm

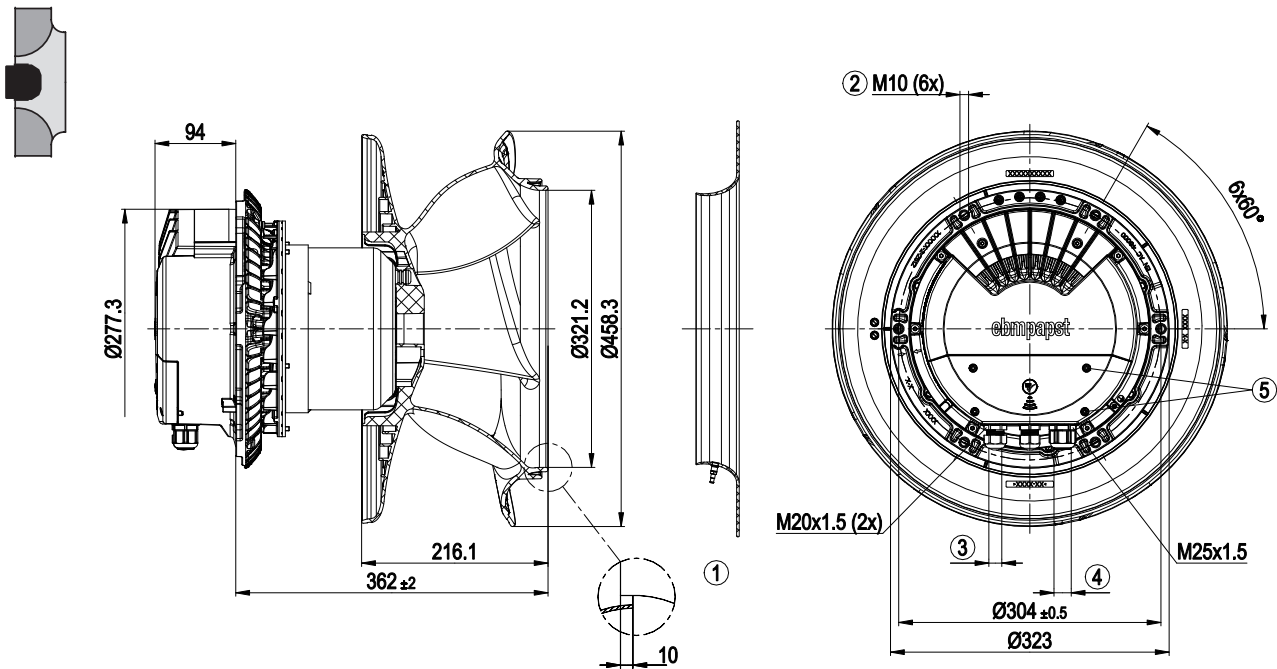

- ① Accessory part: Inlet ring 8217102239 with pressure tap (k-factor: 232) (not included in scope of delivery)
- ② Max. clearance for screw 20 mm
- ③ Cable diameter min. 4 mm, max. 10 mm, tightening torque  $4 \pm 0.6$  Nm
- ④ Cable diameter min. 5 mm, max. 14 mm, tightening torque  $6 \pm 0.9$  Nm  
(The tightening torque is designed for PVC cables. If the cable materials are different, the tightening torque may have to be adjusted)
- ⑤ Tightening torque  $3 \pm 0.3$  Nm

Pin assignment: See connection diagram  
Mounting position: Shaft horizontal or rotor on bottom; rotor on top on request

## H VBH0450CTTPS 8300100075 EC centrifugal module - RadiPac

Dimensions in mm

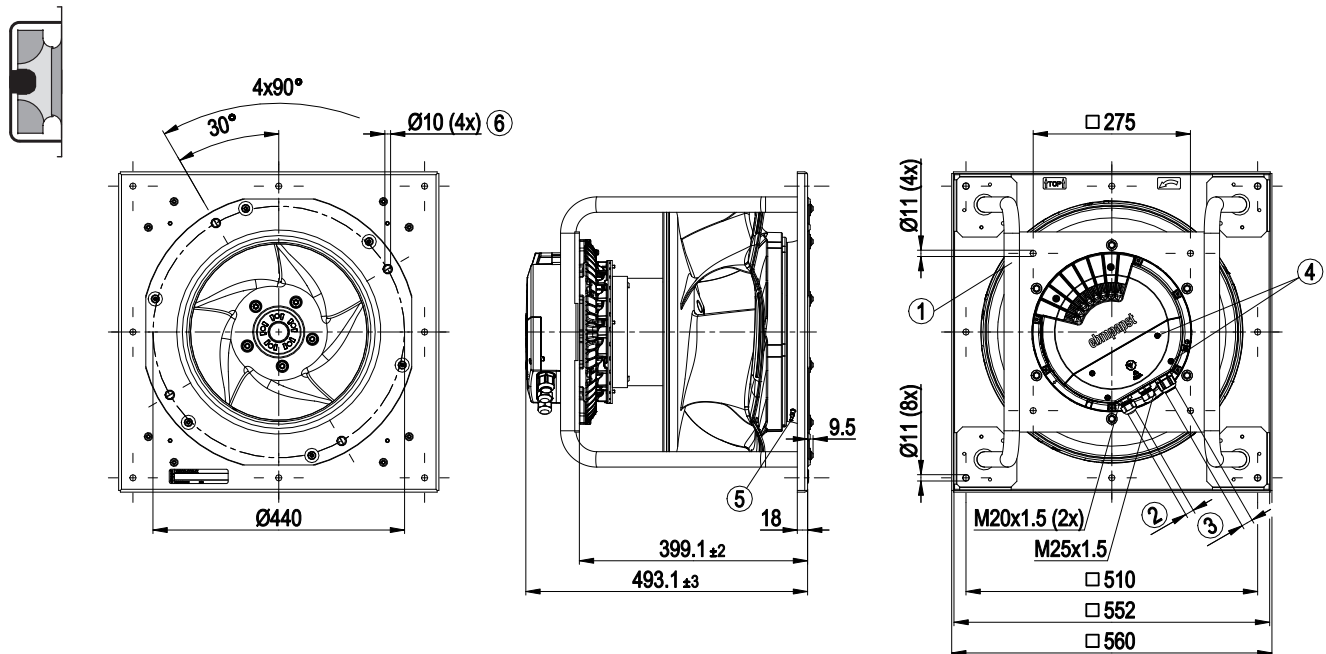

- ① Installed position: shaft horizontal (install support struts only vertically as illustrated) or rotor on bottom; rotor on top on request
- ② Cable diameter min. 4 mm, max. 10 mm, tightening torque  $4 \pm 0.6$  Nm
- ③ Cable diameter min. 5 mm, max. 14 mm, tightening torque  $6 \pm 0.9$  Nm  
(The tightening torque is designed for PVC cables. If the cable materials are different, the tightening torque may have to be adjusted)
- ④ Tightening torque  $3 \pm 0.3$  Nm
- ⑤ Inlet ring with pressure tap (k-factor: 232)
- ⑥ Fastening holes for FlowGrid 35505-2-2957 (not included in scope of delivery) are provided and must be subsequently opened as required

Pin assignment: See connection diagram  
Mounting position: See legend on product drawing

# RadiPac 500

EC centrifugal fans, backward curved



## Material/Surface

- Support bracket: Steel, painted black
- Support plate: Sheet steel, galvanized
- Inlet nozzle: ABS plastic
- Impeller: PP plastic
- Rotor: Painted black
- Electronics housing: Die-cast aluminum

## Mechanical characteristics

- Number of blades: 5
- Drehrichtung (epM): Clockwise, viewed toward rotor
- Installation position: Shaft horizontal or rotor on bottom; rotor on top on request, See legend on product drawing
- Condensation drainage holes: On rotor side
- Mode: S1
- Motor bearing: Ball bearing

## Additional Information

- Information about touch current, electrical connection, degree of protection, insulation class, environmental protection class, EMC standards as well as standards and approvals can be found in the product-specific data sheets.

from page 66	Drawings
from page 92	Accessories
from page 102	Connection diagrams and technical equipment
from page 110	Environment and general conditions
More at	<a href="http://www.ebmpapst.com/worldwide">www.ebmpapst.com/worldwide</a> <a href="http://www.ebmpapst.com/">www.ebmpapst.com/</a>

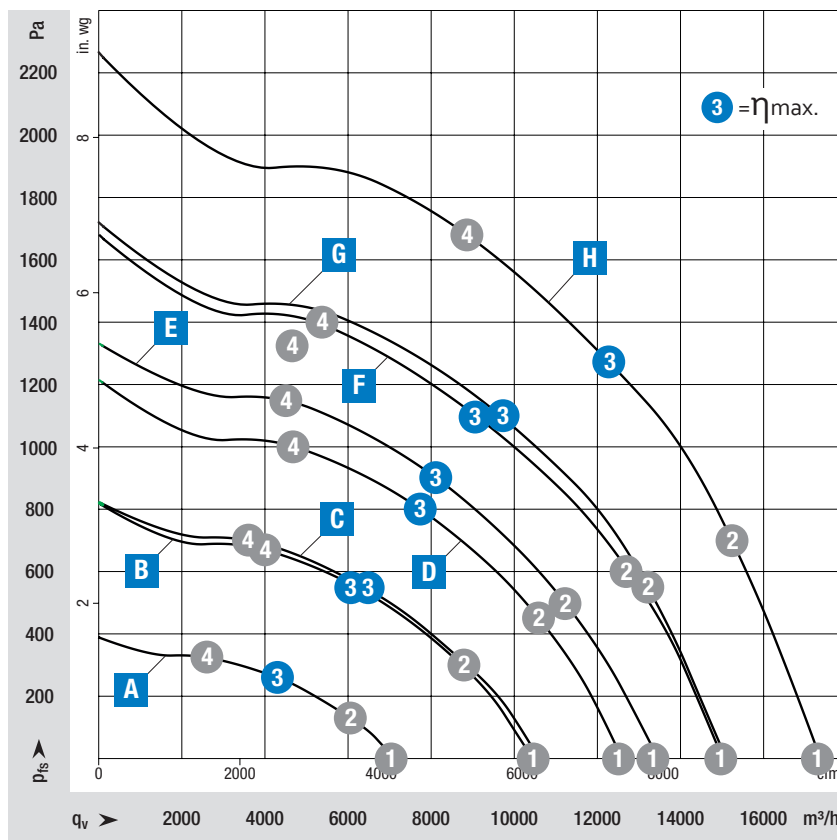

### Measuring conditions

















Air performance measured after: ISO 5801, installation category A, with ebm-papst inlet nozzle without contact protection.

Suction-side noise level: L<sub>WA</sub> according to ISO 13347, L<sub>pA</sub> measured at a distance of 1 m on the fan axis.

The specifications apply only under the specified measuring conditions and may change due to installation conditions.

In case of deviations from the standard design, the characteristic values must be checked in the installed condition!



Nominal voltage range 1- 200-277 VAC, 50/60 Hz			Characteristic Curve	Operating point	Nominal voltage	Speed n	Max. Input power P <sub>ed</sub>	Max. Input current I	Sound power level L <sub>WA</sub>	Max. back pressure Pa	Perm. ambient temp.	Protection class	Connection diagrams and technical equipment
Type	Part number	Fan type			V	rpm	W	A	dB(A)	Pa	°C		
VBS0500CSPMS	8300100259	Centrifugal fan	 Short-version	A	1	230	1,170	319	1.41	76	-25...+40	IP55	Page 105
					2	230	1,170	425	1.86	71			
					3	230	1,170	500	2.20	64			
					4	230	1,170	448	1.96	65			
VBH0500CSPMS	8300100260	Support bracket	 Short-version										
Nominal voltage range 3- 380-480 VAC, 50/60 Hz					V	rpm	W	A	dB(A)	Pa	°C		
Type	Part number	Fan type											
VBS0500CTRLS	8300100494	Centrifugal fan	 Short-version	B	1	400	1,740	955	1.48	84	-40...+40	IP55	Page 103
					2	400	1,740	1,263	1.94	78			
					3	400	1,740	1,430	2.20	74			
					4	400	1,740	1,294	1.98	77			
VBH0500CTRLS	8300100498	Support bracket	 Short-version										
VBS0500CTRLS	8300100528	Centrifugal fan	 Long-version	C	1	400	1,710	888	1.38	84	-40...+40	IP55	Page 105
					2	400	1,710	1,208	1.86	78			
					3	400	1,710	1,380	2.10	72			
					4	400	1,710	1,274	1.95	75			
VBH0500CTRLS	8300100529	Support bracket	 Long-version										
VBS0500CTRNS	8300100266	Centrifugal fan	 Short-version	D	1	400	2,240	2,044	3.20	91	-40...+40	IP55	Page 102
					2	400	2,240	2,650	4.09	84			
					3	400	2,240	3,000	4.70	80			
					4	400	2,240	2,700	4.16	84			
VBH0500CTRNS	8300100265	Support bracket	 Short-version										
VBS0500CTRNS	8300100318	Centrifugal fan	 Long-version	E	1	400	2,070	1,604	2.56	88	-40...+40	IP55	Page 102
					2	400	2,070	2,201	3.43	83			
					3	400	2,070	2,500	3.90	78			
					4	400	2,070	2,280	3.55	81			
VBH0500CTRNS	8300100319	Support bracket	 Long-version										
VBS0500CTTLS	8300100534	Centrifugal fan	 Long-version PFC-active	F	1	400	2,450	2,647	3.82	93	-40...+40	IP55	Page 104
					2	400	2,450	3,651	5.27	87			
					3	400	2,450	4,000	5.80	81			
					4	400	2,450	3,715	5.36	86			
VBH0500CTTLS	8300100547	Support bracket	 Long-version PFC-active										
VBS0500CTTLS	8300100083	Centrifugal fan	 Long-version	G	1	400	2,480	2,549	3.94	94	-40...+40	IP55	Page 102
					2	400	2,480	3,644	5.57	88			
					3	400	2,480	4,150	6.30	82			
					4	400	2,480	3,847	5.87	86			
VBH0500CTTLS	8300100082	Support bracket	 Long-version										
VBS0500CTTRS	8300100069	Centrifugal fan	 Long-version	H	1	400	2,840	3,945	6.19	97	-40...+40	IP55	Page 102
					2	400	2,840	5,440	8.41	92			
					3	400	2,840	6,210	9.60	88			
					4	400	2,840	6,110	9.38	86			
VBH0500CTTRS	8300100068	Support bracket	 Long-version										

Subject to changes.

Values set in blue are nominal data at the operating point at maximum load.

# RadiPac 500

**A** VBS0500CSPMS 8300100259 EC centrifugal fan - RadiPac

Dimensions in mm

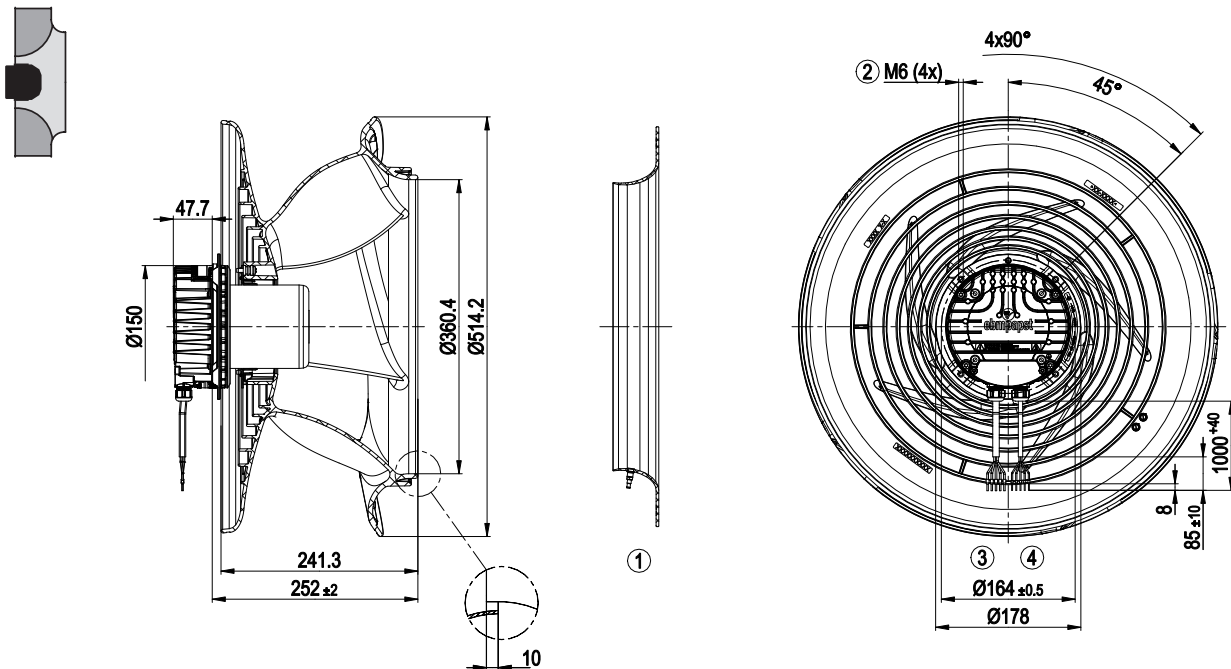

- ① Accessory part: Inlet ring 8217102238 with pressure tap (k-factor: 290) (not included in scope of delivery)
- ② Max. clearance for screw 16 mm
- ③ Cable PVC AWG18, 5x wire-end ferrule
- ④ Cable PVC AWG22

Pin assignment: See connection diagram  
 Mounting position: Shaft horizontal or rotor on bottom; rotor on top on request

**A** VBH0500CSPMS 8300100260 EC centrifugal module - RadiPac

Dimensions in mm

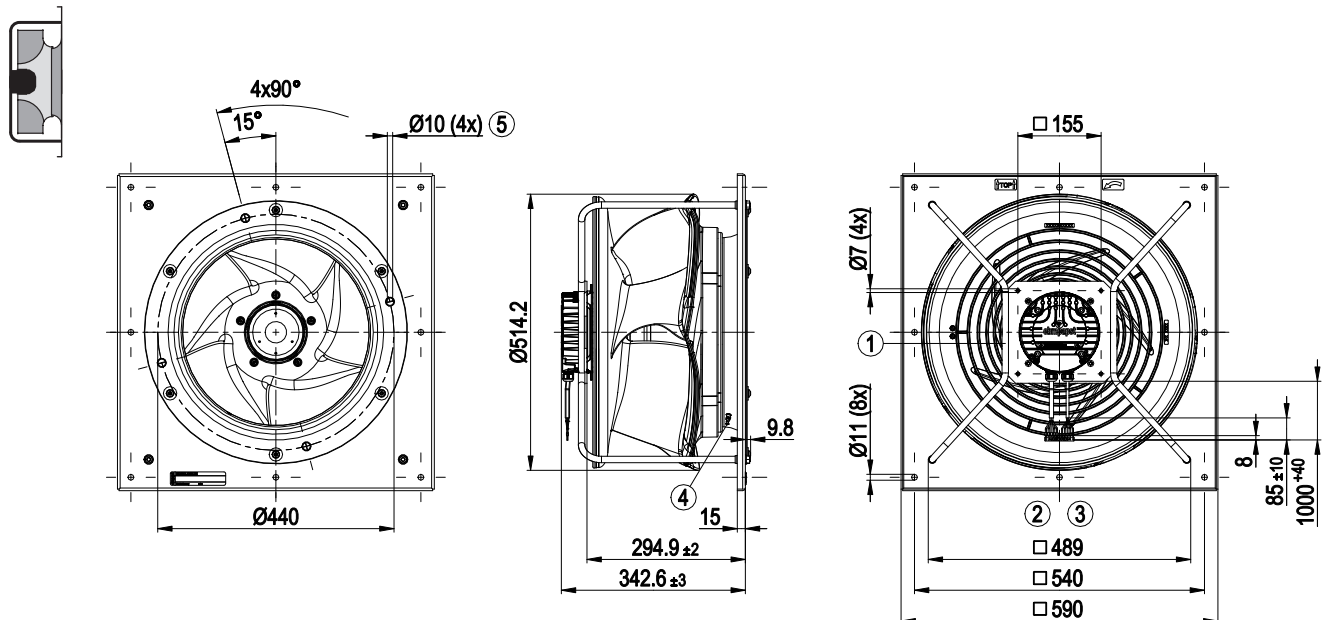

- ① Installed position: shaft horizontal (install support struts only vertically as illustrated) or rotor on bottom; rotor on top on request
- ② Cable PVC AWG18, 5x wire-end ferrule
- ③ Cable PVC AWG22
- ④ Inlet ring with pressure tap (k-factor: 290)
- ⑤ Fastening holes for FlowGrid 35505-2-2957 (not included in scope of delivery) are provided and must be subsequently opened as required

Pin assignment: See connection diagram  
 Mounting position: See legend on product drawing

## B VBS0500CTRLS 8300100494 EC centrifugal fan - RadiPac

Dimensions in mm

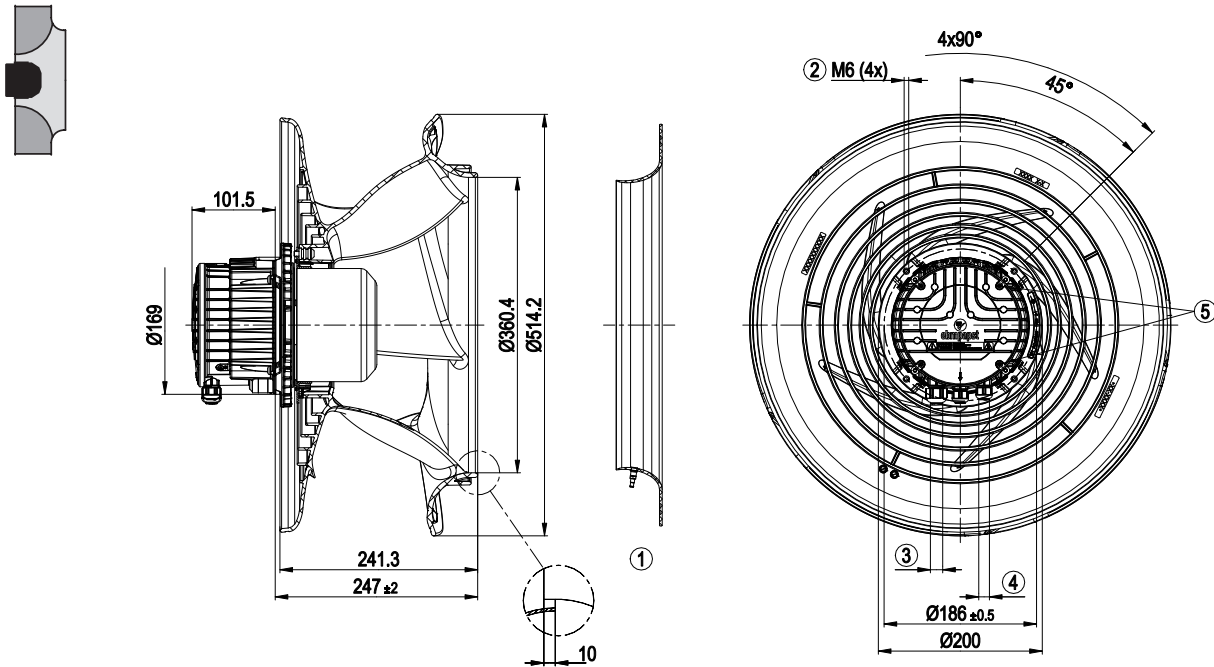

- ① Accessory part: Inlet ring 8217102238 with pressure tap (k-factor: 290) (not included in scope of delivery)
- ② Max. clearance for screw 16 mm
- ③ Cable diameter min. 8 mm, max. 12 mm, tightening torque  $1.8 \pm 0.3$  Nm (use must be made of seal provided); Cable diameter min. 4 mm, max. 10 mm, tightening torque  $1.8 \pm 0.3$  Nm
- ④ Cable diameter min. 6 mm, max. 10 mm, tightening torque  $1.8 \pm 0.3$  Nm (use must be made of seal provided); Cable diameter min. 4 mm, max. 7 mm, tightening torque  $1.8 \pm 0.3$  Nm
- ⑤ Tightening torque  $1.5 \pm 0.2$  Nm

Pin assignment: See connection diagram  
 Mounting position: Shaft horizontal or rotor on bottom; rotor on top on request

## B VBH0500CTRLS 8300100498 EC centrifugal module - RadiPac

Dimensions in mm

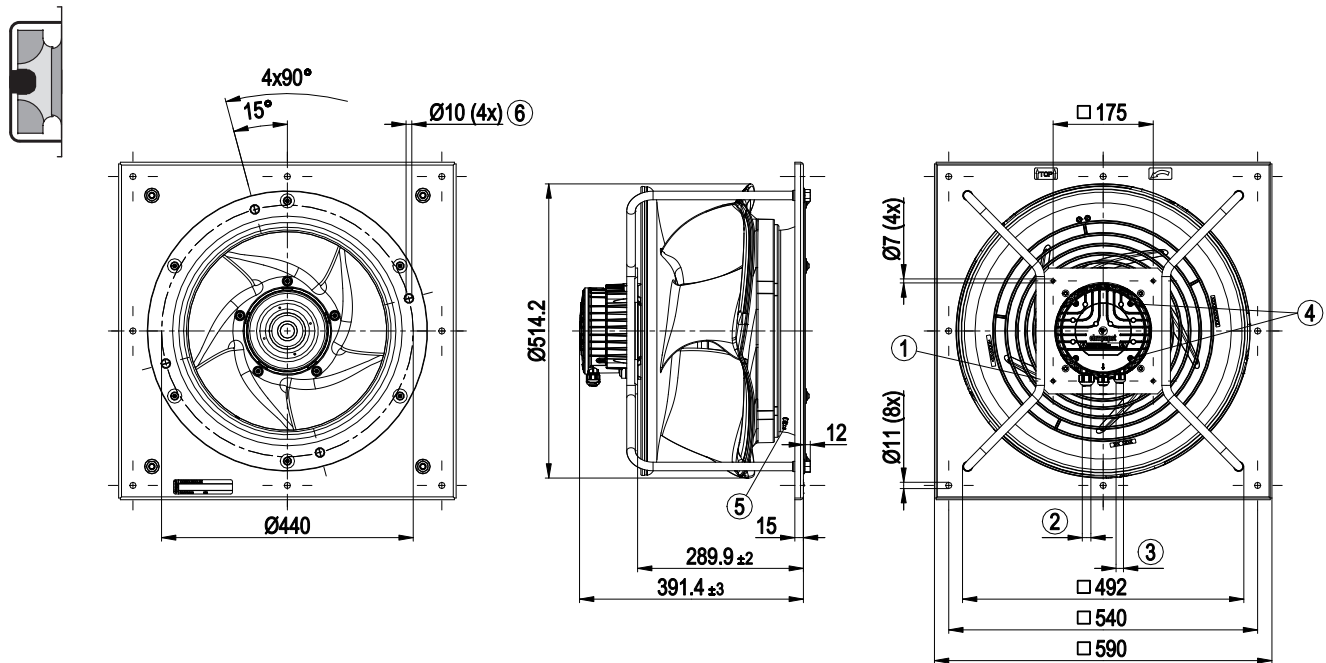

- ① Installed position: shaft horizontal (install support struts only vertically as illustrated) or rotor on bottom; rotor on top on request
- ② Cable diameter min. 8 mm, max. 12 mm, tightening torque  $1.8 \pm 0.3$  Nm (use must be made of seal provided); Cable diameter min. 4 mm, max. 10 mm, tightening torque  $1.8 \pm 0.3$  Nm
- ③ Cable diameter min. 6 mm, max. 10 mm, tightening torque  $1.8 \pm 0.3$  Nm (use must be made of seal provided); Cable diameter min. 4 mm, max. 7 mm, tightening torque  $1.8 \pm 0.3$  Nm
- ④ Tightening torque  $1.5 \pm 0.2$  Nm
- ⑤ Inlet ring with pressure tap (k-factor: 290)
- ⑥ Fastening holes for FlowGrid 35505-2-2957 (not included in scope of delivery) are provided and must be subsequently opened as required

Pin assignment: See connection diagram  
 Mounting position: See legend on product drawing

# RadiPac 500

C VBS0500CTRLS 8300100528 EC centrifugal fan - RadiPac

Dimensions in mm

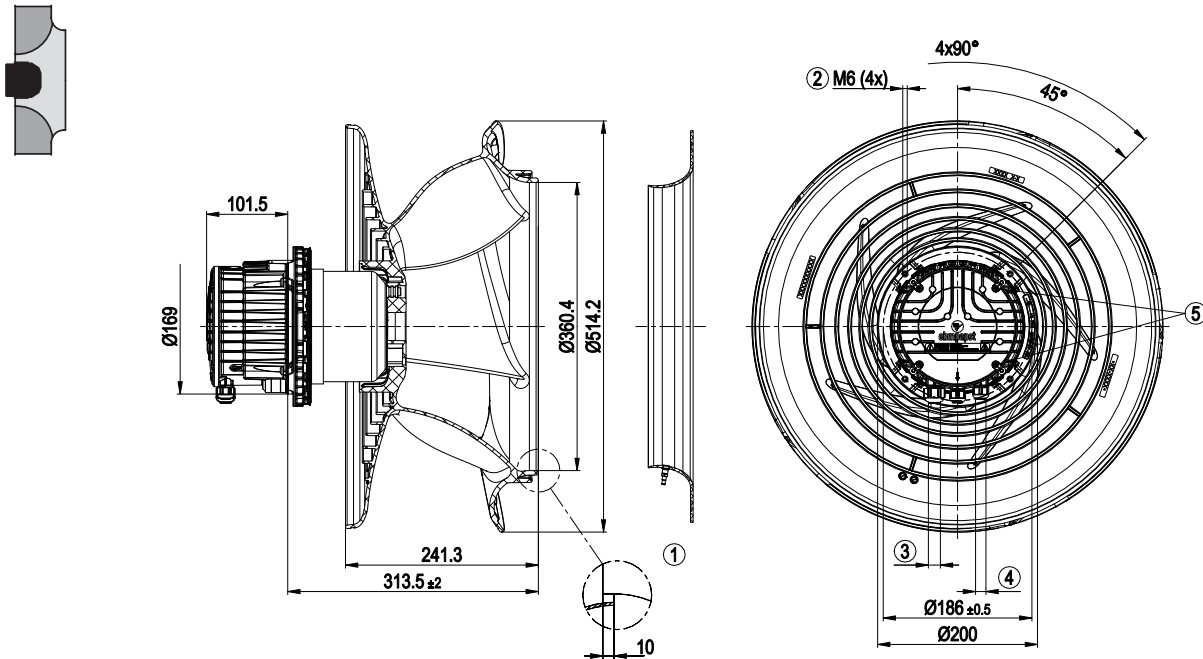

- ① Accessory part: Inlet ring 8217102238 with pressure tap (k-factor: 290) (not included in scope of delivery)
- ② Max. clearance for screw 16 mm
- ③ Cable diameter min. 8 mm, max. 12 mm, tightening torque  $1.8 \pm 0.3$  Nm (use must be made of seal provided); Cable diameter min. 4 mm, max. 10 mm, tightening torque  $1.8 \pm 0.3$  Nm
- ④ Cable diameter min. 6 mm, max. 10 mm, tightening torque  $1.8 \pm 0.3$  Nm (use must be made of seal provided); Cable diameter min. 4 mm, max. 7 mm, tightening torque  $1.8 \pm 0.3$  Nm
- ⑤ Tightening torque  $1.5 \pm 0.2$  Nm

Pin assignment: See connection diagram  
Mounting position: Shaft horizontal or rotor on bottom; rotor on top on request

C VBH0500CTRLS 8300100529 EC centrifugal module - RadiPac

Dimensions in mm

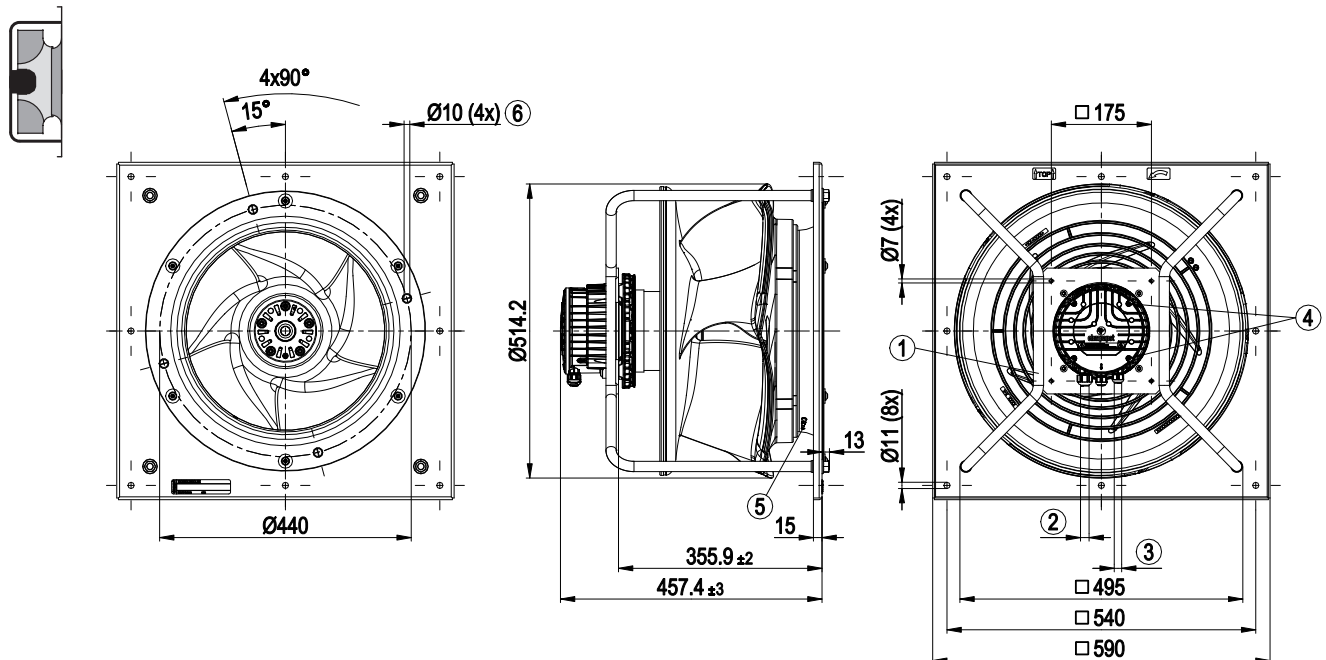

- ① Installed position: shaft horizontal (install support struts only vertically as illustrated) or rotor on bottom; rotor on top on request
- ② Cable diameter min. 8 mm, max. 12 mm, tightening torque  $1.8 \pm 0.3$  Nm (use must be made of seal provided); Cable diameter min. 4 mm, max. 10 mm, tightening torque  $1.8 \pm 0.3$  Nm
- ③ Cable diameter min. 6 mm, max. 10 mm, tightening torque  $1.8 \pm 0.3$  Nm (use must be made of seal provided); Cable diameter min. 4 mm, max. 7 mm, tightening torque  $1.8 \pm 0.3$  Nm
- ④ Tightening torque  $1.5 \pm 0.2$  Nm
- ⑤ Inlet ring with pressure tap (k-factor: 290)
- ⑥ Fastening holes for FlowGrid 35505-2-2957 (not included in scope of delivery) are provided and must be subsequently opened as required

Pin assignment: See connection diagram  
Mounting position: See legend on product drawing

## D VBS0500CTRNS 8300100266 EC centrifugal fan - RadiPac

Dimensions in mm

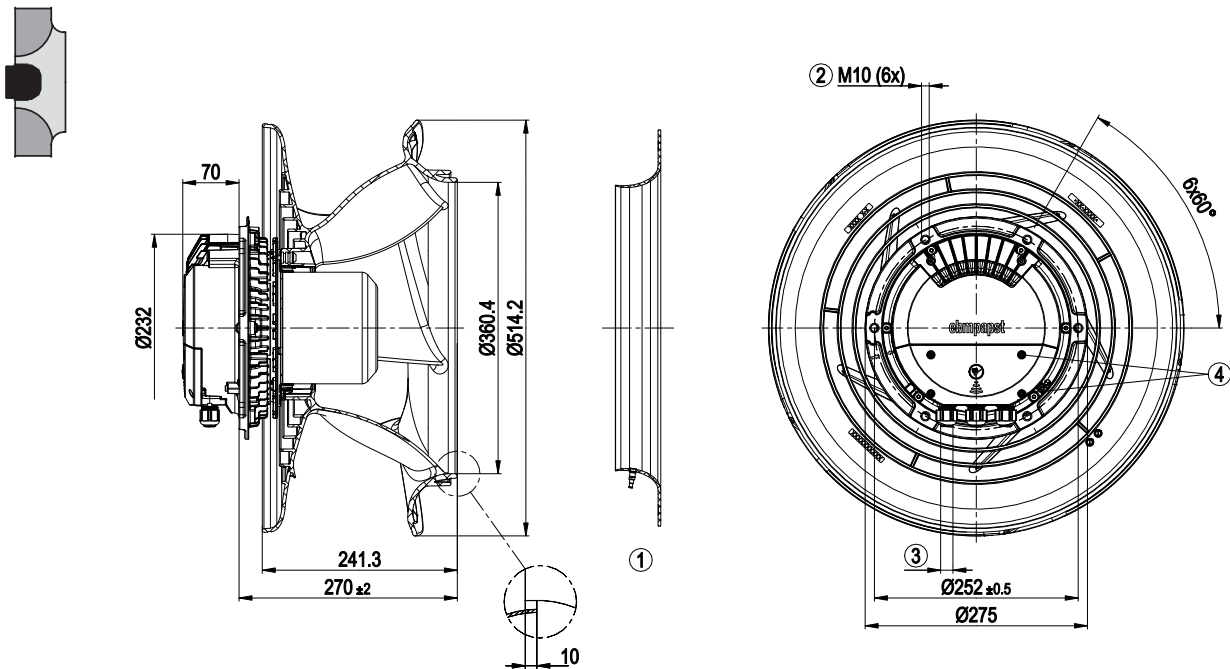

- ① Accessory part: Inlet ring 8217102238 with pressure tap (k-factor: 290) (not included in scope of delivery)
- ② Max. clearance for screw 20 mm
- ③ Cable diameter min. 4 mm, max. 10 mm, tightening torque  $4 \pm 0.6$  Nm  
(The tightening torque is designed for PVC cables. If the cable materials are different, the tightening torque may have to be adjusted)
- ④ Tightening torque  $1.5 \pm 0.2$  Nm

Pin assignment: See connection diagram  
Mounting position: Shaft horizontal or rotor on bottom; rotor on top on request

## D VBH0500CTRNS 8300100265 EC centrifugal module - RadiPac

Dimensions in mm

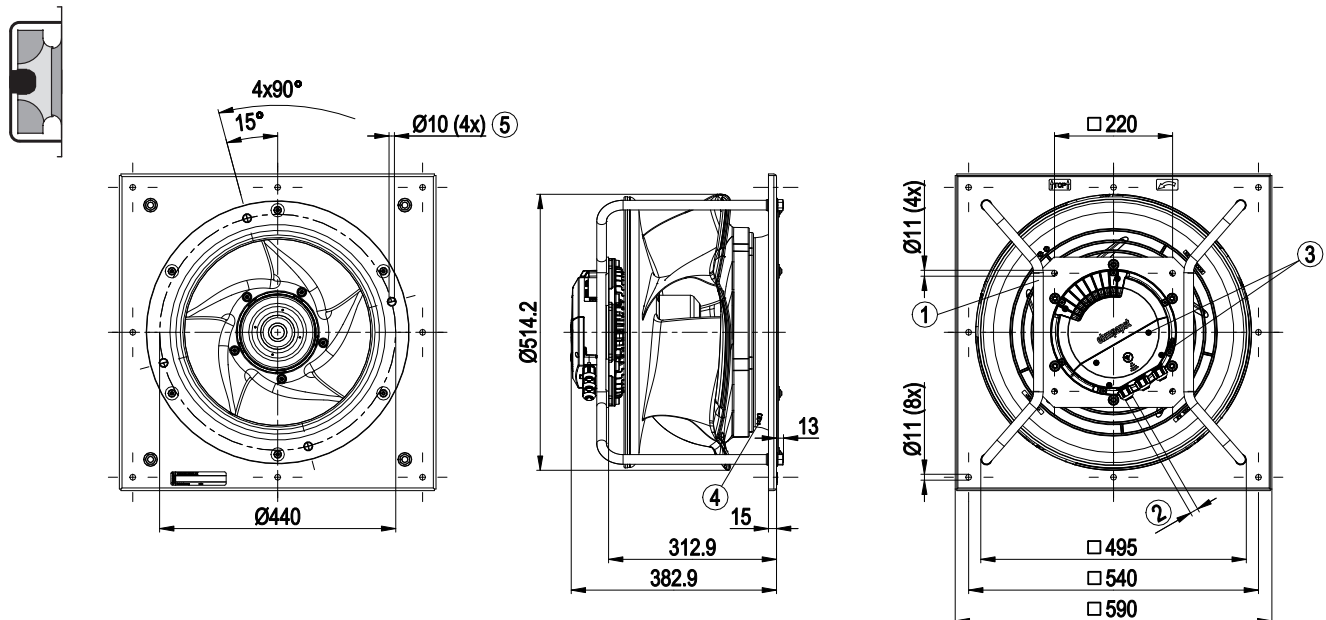

- ① Installed position: shaft horizontal (install support struts only vertically as illustrated) or rotor on bottom; rotor on top on request
- ② Cable diameter min. 4 mm, max. 10 mm, tightening torque  $4 \pm 0.6$  Nm  
(The tightening torque is designed for PVC cables. If the cable materials are different, the tightening torque may have to be adjusted)
- ③ Tightening torque  $1.5 \pm 0.2$  Nm
- ④ Inlet ring with pressure tap (k-factor: 290)
- ⑤ Fastening holes for FlowGrid 35505-2-2957 (not included in scope of delivery) are provided and must be subsequently opened as required

Pin assignment: See connection diagram  
Mounting position: See legend on product drawing

# RadiPac 500

**E** VBS0500CTRNS 8300100318 EC centrifugal fan - RadiPac

Dimensions in mm

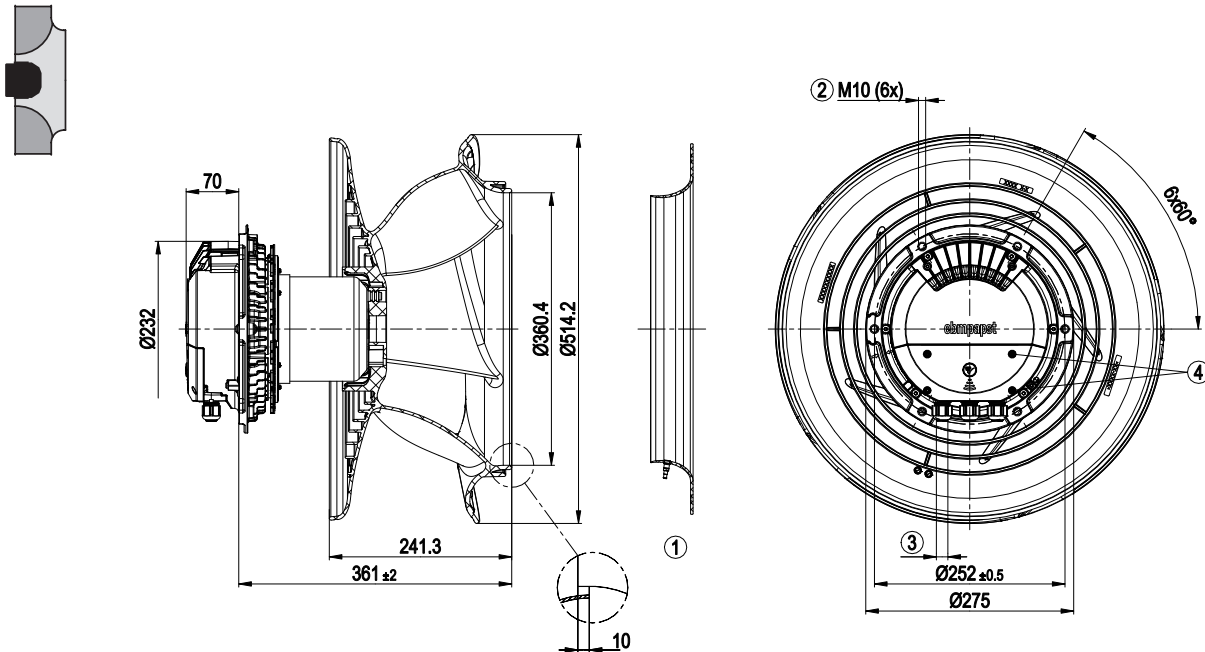

- ① Accessory part: Inlet ring 8217102238 with pressure tap (k-factor: 290) (not included in scope of delivery)
- ② Max. clearance for screw 20 mm
- ③ Cable diameter min. 4 mm, max. 10 mm, tightening torque  $4 \pm 0.6$  Nm  
(The tightening torque is designed for PVC cables. If the cable materials are different, the tightening torque may have to be adjusted)
- ④ Tightening torque  $1.5 \pm 0.2$  Nm

Pin assignment: See connection diagram  
Mounting position: Shaft horizontal or rotor on bottom; rotor on top on request

**E** VBH0500CTRNS 8300100319 EC centrifugal module - RadiPac

Dimensions in mm

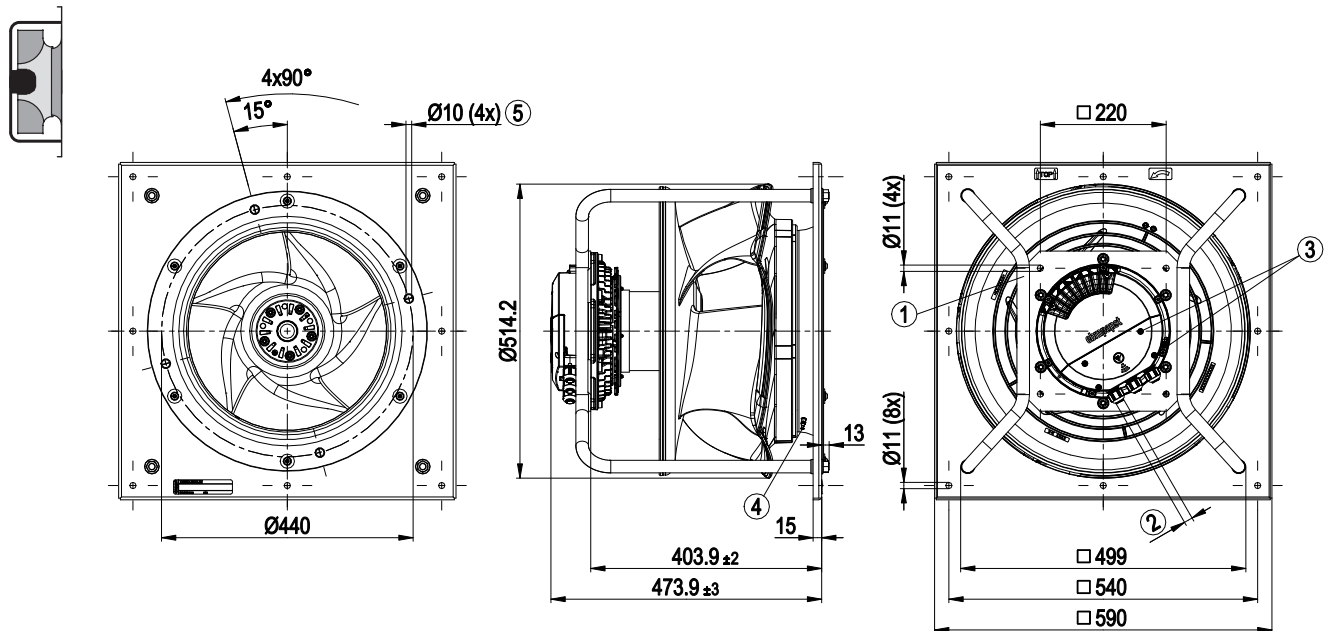

- ① Installed position: shaft horizontal (install support struts only vertically as illustrated) or rotor on bottom; rotor on top on request
- ② Cable diameter min. 4 mm, max. 10 mm, tightening torque  $4 \pm 0.6$  Nm  
(The tightening torque is designed for PVC cables. If the cable materials are different, the tightening torque may have to be adjusted)
- ③ Tightening torque  $1.5 \pm 0.2$  Nm
- ④ Inlet ring with pressure tap (k-factor: 290)
- ⑤ Fastening holes for FlowGrid 35505-2-2957 (not included in scope of delivery) are provided and must be subsequently opened as required

Pin assignment: See connection diagram  
Mounting position: See legend on product drawing

## F VBS0500CTTLS 8300100534 EC centrifugal fan - RadiPac

Dimensions in mm

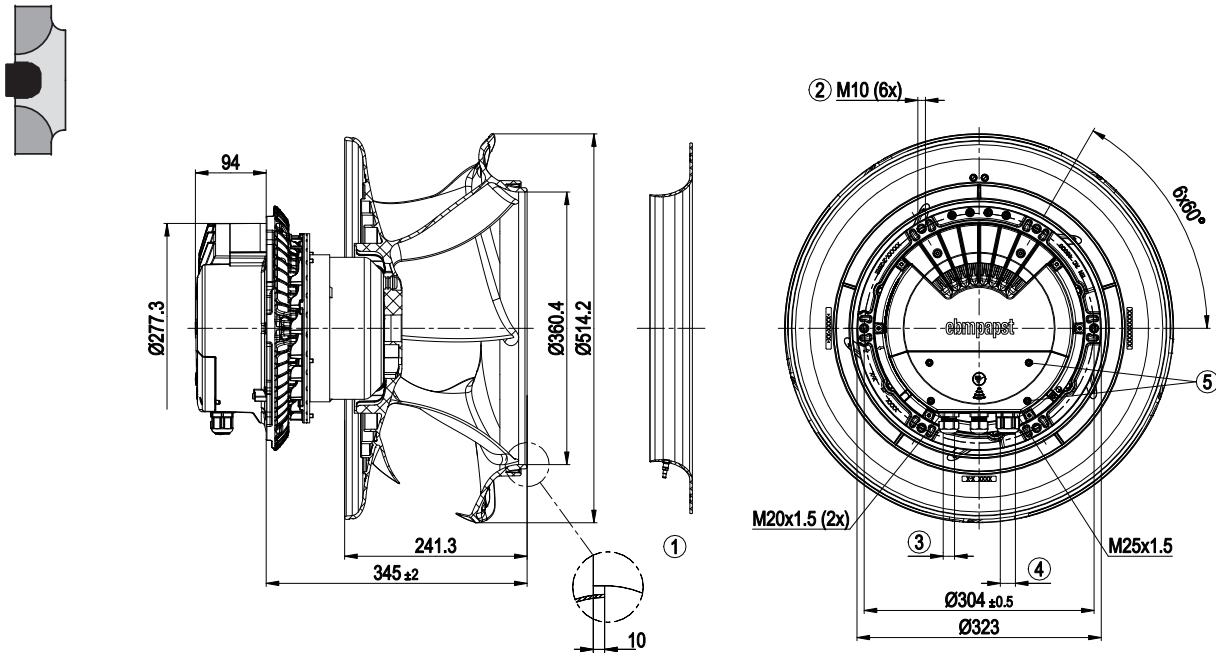

- ① Accessory part: Inlet ring 8217102238 with pressure tap (k-factor: 290) (not included in scope of delivery)
- ② Max. clearance for screw 20 mm
- ③ Cable diameter min. 4 mm, max. 10 mm, tightening torque  $4 \pm 0.6$  Nm
- ④ Cable diameter min. 5 mm, max. 14 mm, tightening torque  $6 \pm 0.9$  Nm  
(The tightening torque is designed for PVC cables. If the cable materials are different, the tightening torque may have to be adjusted)
- ⑤ Tightening torque  $3 \pm 0.3$  Nm

Pin assignment: See connection diagram  
Mounting position: Shaft horizontal or rotor on bottom; rotor on top on request

## F VBH0500CTTLS 8300100547 EC centrifugal module - RadiPac

Dimensions in mm

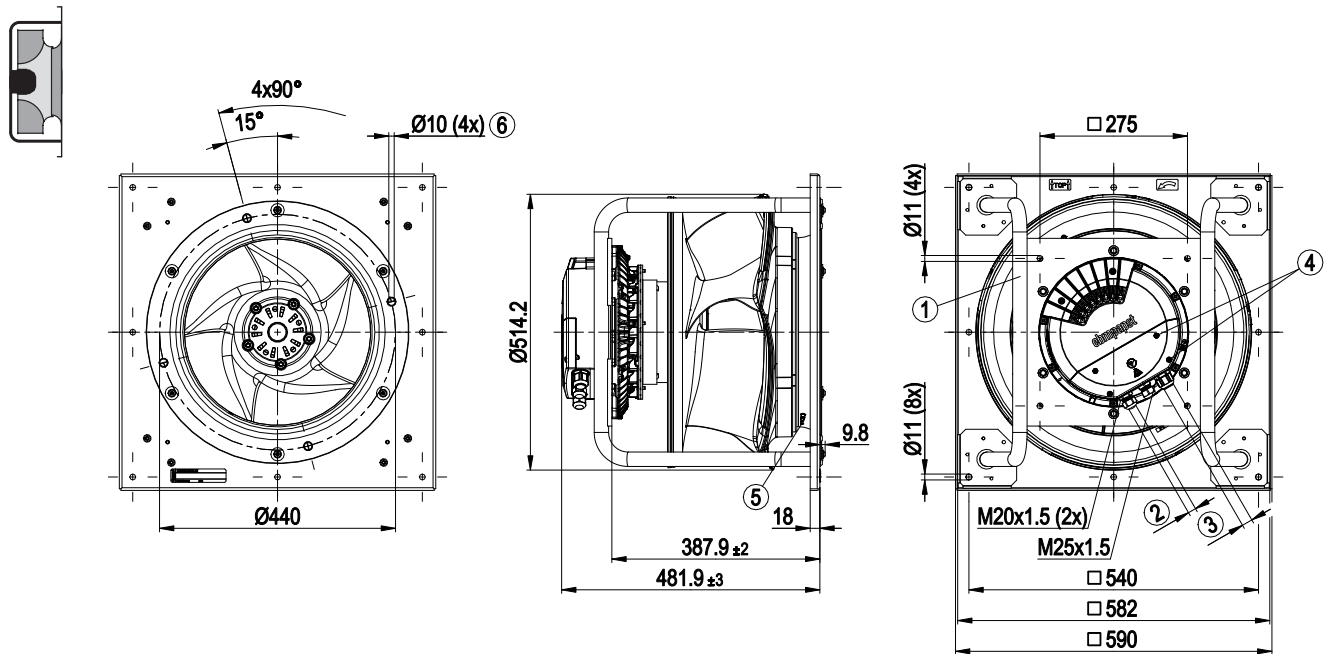

- ① Installed position: shaft horizontal (install support struts only vertically as illustrated) or rotor on bottom; rotor on top on request
- ② Cable diameter min. 4 mm, max. 10 mm, tightening torque  $4 \pm 0.6$  Nm
- ③ Cable diameter min. 5 mm, max. 14 mm, tightening torque  $6 \pm 0.9$  Nm  
(The tightening torque is designed for PVC cables. If the cable materials are different, the tightening torque may have to be adjusted)
- ④ Tightening torque  $3 \pm 0.3$  Nm
- ⑤ Inlet ring with pressure tap (k-factor: 290)
- ⑥ Fastening holes for FlowGrid 35505-2-2957 (not included in scope of delivery) are provided and must be subsequently opened as required

Pin assignment: See connection diagram  
Mounting position: Shaft horizontal or rotor on bottom; rotor on top on request

# RadiPac 500

G VBS0500CTTLS 8300100083 EC centrifugal fan - RadiPac

Dimensions in mm

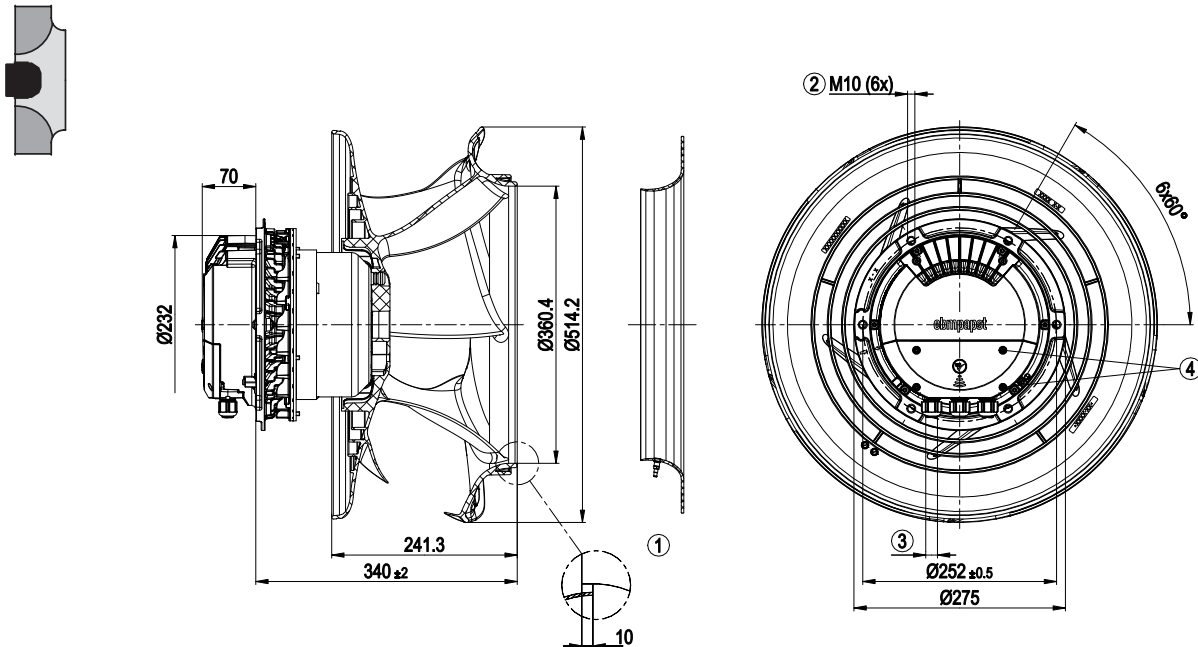

- ① Accessory part: Inlet ring 8217102238 with pressure tap (k-factor: 290) (not included in scope of delivery)
- ② Max. clearance for screw 20 mm
- ③ Cable diameter min. 4 mm, max. 10 mm, tightening torque  $4 \pm 0.6$  Nm  
(The tightening torque is designed for PVC cables. If the cable materials are different, the tightening torque may have to be adjusted)
- ④ Tightening torque  $1.5 \pm 0.2$  Nm

Pin assignment: See connection diagram  
Mounting position: Shaft horizontal or rotor on bottom; rotor on top on request

G VBH0500CTTLS 8300100082 EC centrifugal module - RadiPac

Dimensions in mm

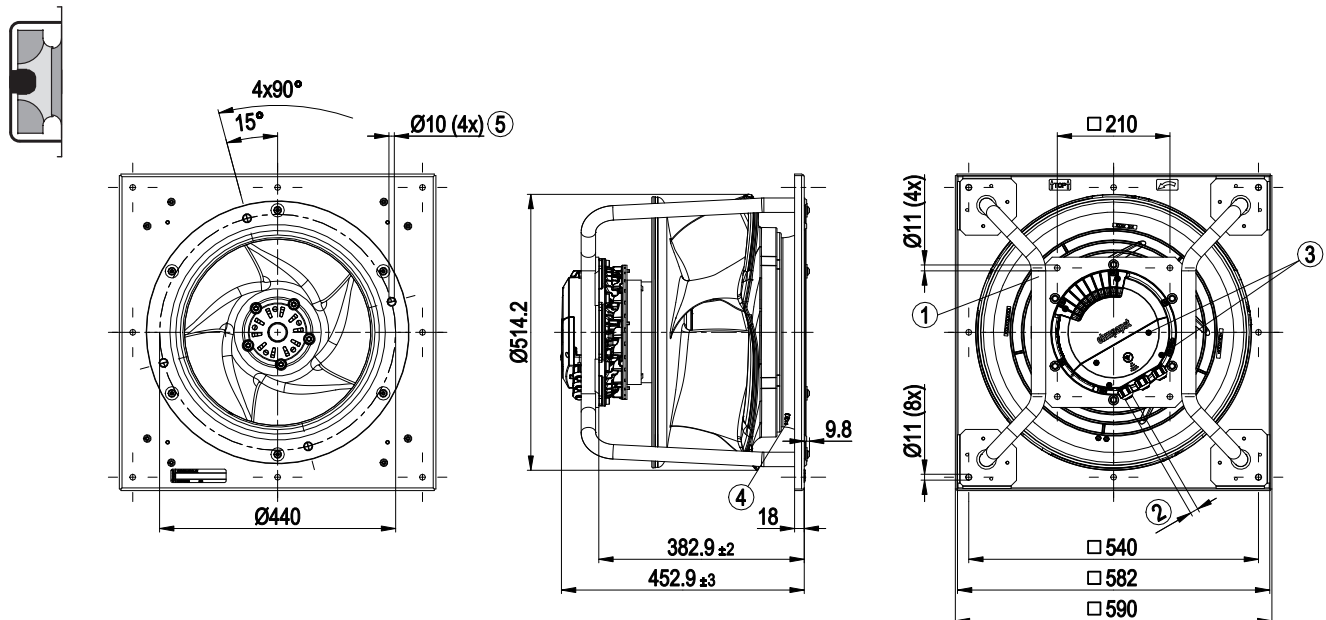

- ① Installed position: shaft horizontal (install support struts only vertically as illustrated) or rotor on bottom; rotor on top on request
- ② Cable diameter min. 4 mm, max. 10 mm, tightening torque  $4 \pm 0.6$  Nm  
(The tightening torque is designed for PVC cables. If the cable materials are different, the tightening torque may have to be adjusted)
- ③ Tightening torque  $1.5 \pm 0.2$  Nm
- ④ Inlet ring with pressure tap (k-factor: 290)
- ⑤ Fastening holes for FlowGrid 35505-2-2957 (not included in scope of delivery) are provided and must be subsequently opened as required

Pin assignment: See connection diagram  
Mounting position: See legend on product drawing



## H VBS0500CTTRS 8300100069 EC centrifugal fan - RadiPac

Dimensions in mm

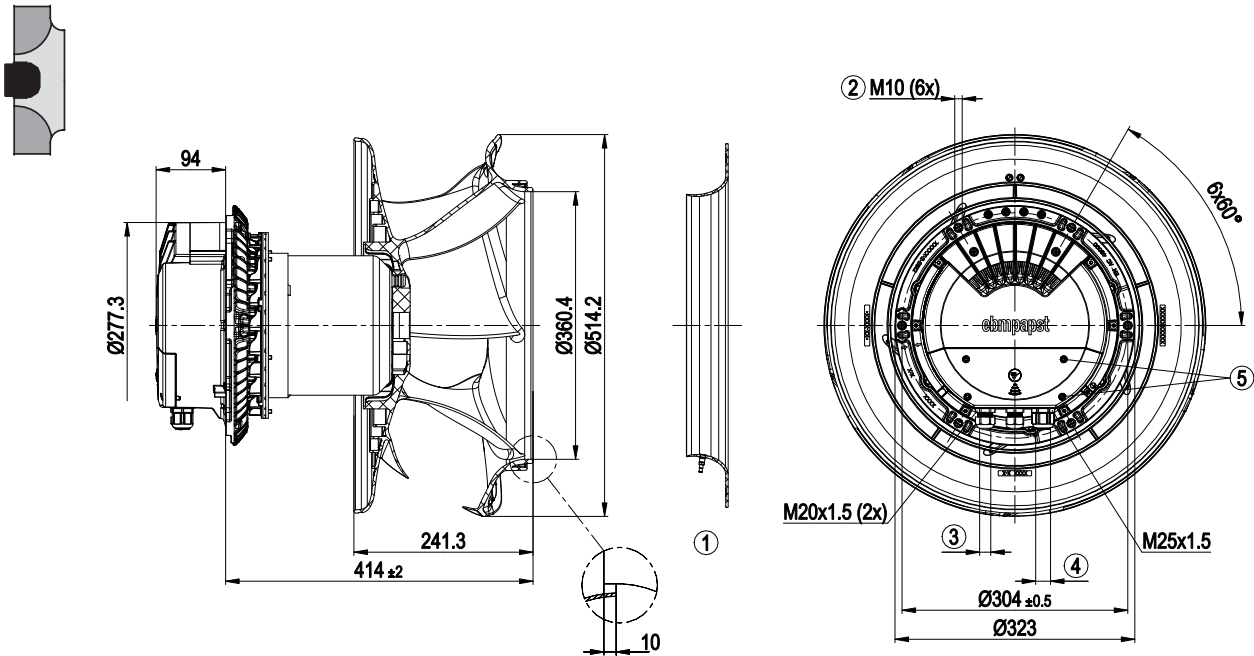

- ① Accessory part: Inlet ring 8217102238 with pressure tap (k-factor: 290) (not included in scope of delivery)
- ② Max. clearance for screw 20 mm
- ③ Cable diameter min. 4 mm, max. 10 mm, tightening torque  $4 \pm 0.6$  Nm
- ④ Cable diameter min. 5 mm, max. 14 mm, tightening torque  $6 \pm 0.9$  Nm  
(The tightening torque is designed for PVC cables. If the cable materials are different, the tightening torque may have to be adjusted)
- ⑤ Tightening torque  $3 \pm 0.3$  Nm

Pin assignment: See connection diagram  
Mounting position: Shaft horizontal or rotor on bottom; rotor on top on request

## H VBH0500CTTRS 8300100068 EC centrifugal module - RadiPac

Dimensions in mm

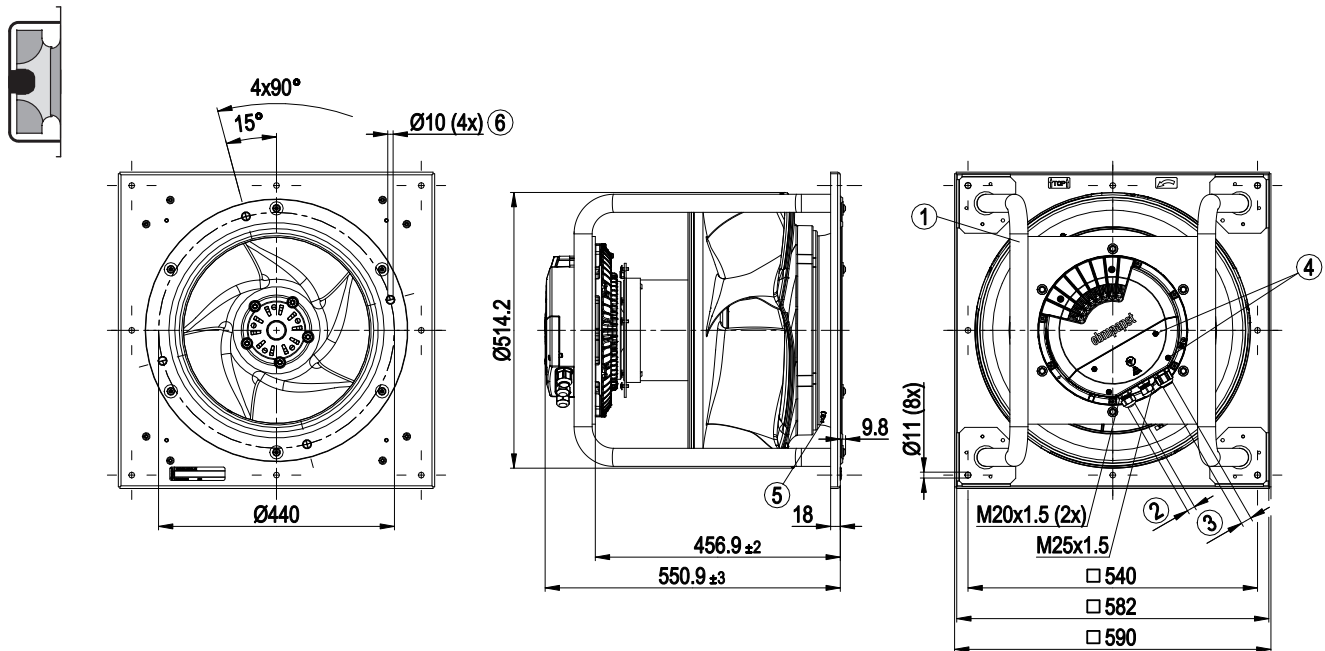

- ① Installed position: shaft horizontal (install support struts only vertically as illustrated) or rotor on bottom; rotor on top on request
- ② Cable diameter min. 4 mm, max. 10 mm, tightening torque  $4 \pm 0.6$  Nm
- ③ Cable diameter min. 5 mm, max. 14 mm, tightening torque  $6 \pm 0.9$  Nm  
(The tightening torque is designed for PVC cables. If the cable materials are different, the tightening torque may have to be adjusted)
- ④ Tightening torque  $3 \pm 0.3$  Nm
- ⑤ Inlet ring with pressure tap (k-factor: 290)
- ⑥ Fastening holes for FlowGrid 35505-2-2957 (not included in scope of delivery) are provided and must be subsequently opened as required

Pin assignment: See connection diagram  
Mounting position: See legend on product drawing

# RadiPac 560

EC centrifugal fans, backward curved



## Material/Surface

- Support bracket: Steel, painted black
- Support plate: Sheet steel, galvanized
- Inlet nozzle: ABS plastic
- Impeller: PP plastic
- Rotor: Painted black
- Electronics housing: Die-cast aluminum

## Mechanical characteristics

- Number of blades: 5
- Drehrichtung (epM): Clockwise, viewed toward rotor
- Installation position: Shaft horizontal or rotor on bottom; rotor on top on request, See legend on product drawing
- Condensation drainage holes: On rotor side
- Mode: S1
- Motor bearing: Ball bearing

## Additional Information





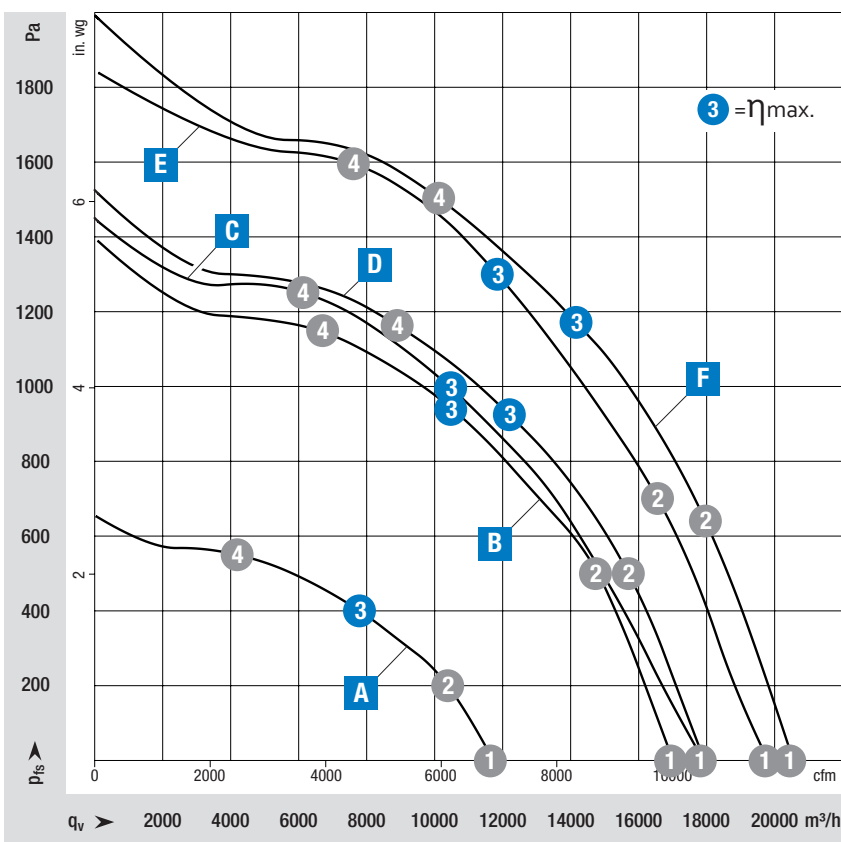





- Information about touch current, electrical connection, degree of protection, insulation class, environmental protection class, EMC standards as well as standards and approvals can be found in the product-specific data sheets.

from page 76	Drawings
from page 92	Accessories
from page 102	Connection diagrams and technical equipment
from page 110	Environment and general conditions
More at	<a href="http://www.ebmpapst.com/worldwide">www.ebmpapst.com/worldwide</a> <a href="http://www.ebmpapst.com/">www.ebmpapst.com/</a>



### Measuring conditions

Air performance measured after: ISO 5801, installation category A, with ebm-papst inlet nozzle without contact protection.  
Suction-side noise level: LwA according to ISO 13347, LpA measured at a distance of 1 m on the fan axis.  
The specifications apply only under the specified measuring conditions and may change due to installation conditions.  
In case of deviations from the standard design, the characteristic values must be checked in the installed condition!

Nominal voltage range 3- 380-480 VAC, 50/60 Hz			Characteristic Curve	Operating point	Nominal voltage	Speed n	Max. Input power P <sub>ed</sub>	Max. Input current I	Sound power level L <sub>WA</sub>	Max. back pressure	Perm. ambient temp.	Protection class	Connection diagrams and technical equipment	
Type	Part number	Fan type			V	rpm	W	A	dB(A)	Pa	°C			
VBS0560CTRNS	8300100520	Centrifugal fan	 Short-version	A	1	400	1,370	825	1.29	82	---	-40...+40	IP55	Page 103
					2	400	1,370	1,115	1.72	77				
					3	400	1,370	1,270	2.00	72				
					4	400	1,370	1,149	1.77	74				
VBH0560CTRNS	8300100521	Support bracket	 Short-version											
VBS0560CTTPS	8300100535	Centrifugal fan	 Long-version PFC-active	B	1	400	1,990	2,497	3.61	92	---	-40...+40	IP55	Page 104
					2	400	1,990	3,530	5.11	85				
					3	400	1,990	4,000	5.80	79				
					4	400	1,995	3,676	5.32	83				
VBH0560CTTPS	8300100546	Support bracket	 Long-version PFC-active											
VBS0560CTTPS	8300100041	Centrifugal fan	 Short-version	C	1	400	2,080	2,900	4.46	94	---	-40...+40	IP55	Page 102
					2	400	2,080	3,783	5.77	87				
					3	400	2,080	4,250	6.40	83				
					4	400	2,080	3,815	5.82	87				
VBH0560CTTPS	8300100047	Support bracket	 Short-version											
VBS0560CTTPS	8300100096	Centrifugal fan	 Long-version	D	1	400	2,080	2,670	4.12	92	---	-40...+40	IP55	Page 102
					2	400	2,080	3,865	5.90	86				
					3	400	2,080	4,400	6.70	81				
					4	400	2,080	4,355	6.63	81				
VBH0560CTTPS	8300100095	Support bracket	 Long-version											
VBS0560CTTRS	8300100222	Centrifugal fan	 Short-version	E	1	400	2,400	4,611	7.14	98	---	-40...+40	IP55	Page 102
					2	400	2,400	6,012	9.16	93				
					3	400	2,400	6,500	10.0	88				
					4	400	2,400	6,068	9.24	91				
VBH0560CTTRS	8300100221	Support bracket	 Short-version											
VBS0560CTTRS	8300100102	Centrifugal fan	 Long-version	F	1	400	2,370	4,000	6.28	95	---	-40...+40	IP55	Page 103
					2	400	2,370	5,645	8.72	89				
					3	400	2,370	6,500	10.0	84				
					4	400	2,370	6,305	9.68	85				
VBH0560CTTRS	8300100101	Support bracket	 Long-version											

Subject to changes.

Values set in blue are nominal data at the operating point at maximum load.

# RadiPac 560

**A** VBS0560CTRNS 8300100520 EC centrifugal fan - RadiPac

Dimensions in mm

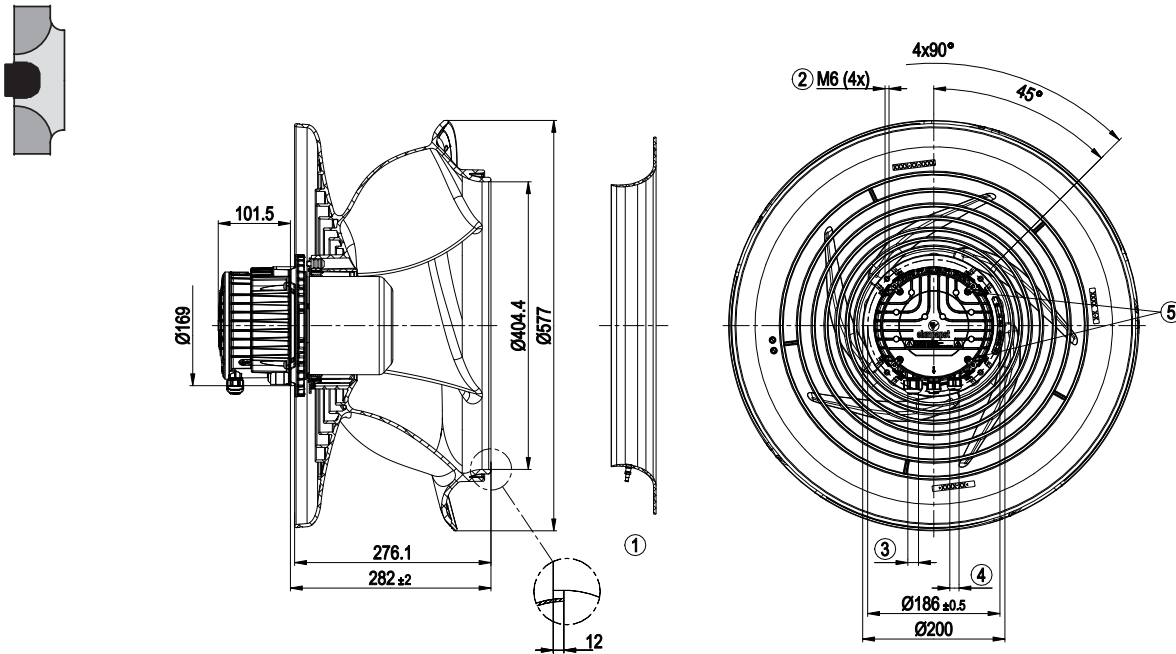

- ① Accessory part: Inlet ring 8217102237 with pressure tap (k-factor: 381) (not included in scope of delivery)
- ② Max. clearance for screw 16 mm
- ③ Cable diameter min. 8 mm, max. 12 mm, tightening torque  $1.8 \pm 0.3$  Nm (use must be made of seal provided); Cable diameter min. 4 mm, max. 10 mm, tightening torque  $1.8 \pm 0.3$  Nm
- ④ Cable diameter min. 6 mm, max. 10 mm, tightening torque  $1.8 \pm 0.3$  Nm (use must be made of seal provided); Cable diameter min. 4 mm, max. 7 mm, tightening torque  $1.8 \pm 0.3$  Nm
- ⑤ Tightening torque  $1.5 \pm 0.2$  Nm

Pin assignment: See connection diagram  
Mounting position: Shaft horizontal or rotor on bottom; rotor on top on request

**A** VBH0560CTRNS 8300100521 EC centrifugal module - RadiPac

Dimensions in mm

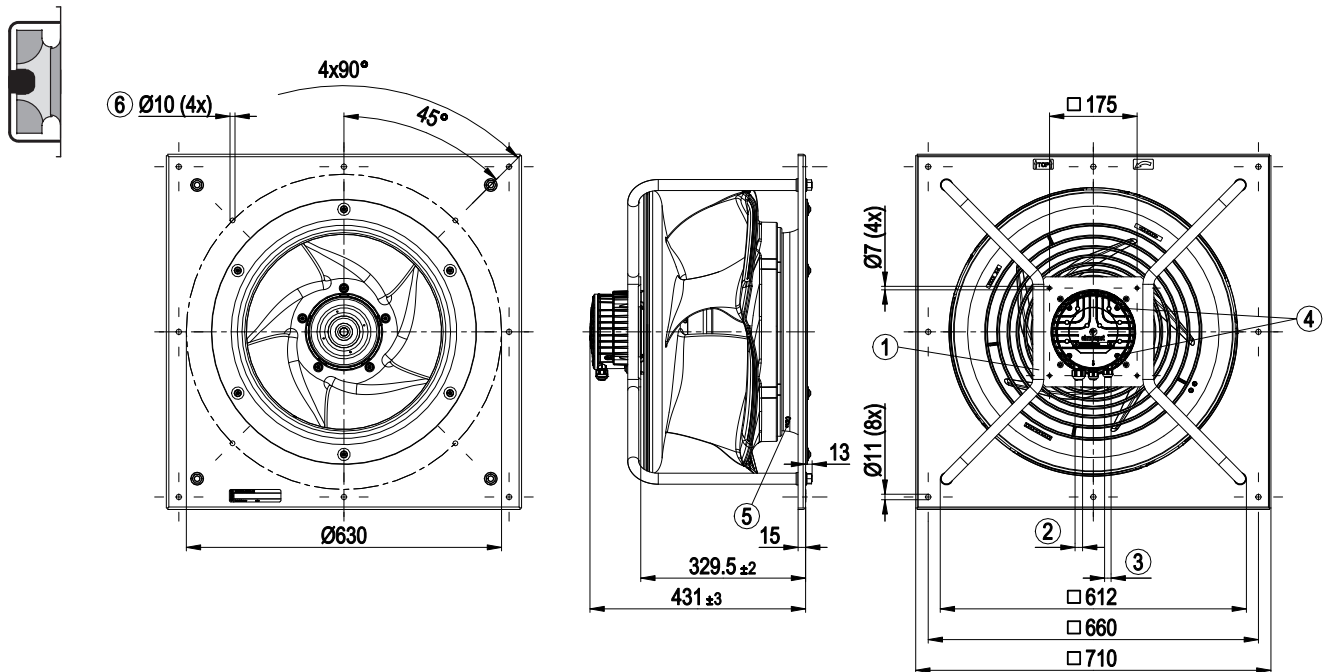

- ① Installed position: shaft horizontal (install support struts only vertically as illustrated) or rotor on bottom; rotor on top on request
- ② Cable diameter min. 8 mm, max. 12 mm, tightening torque  $1.8 \pm 0.3$  Nm (use must be made of seal provided); Cable diameter min. 4 mm, max. 10 mm, tightening torque  $1.8 \pm 0.3$  Nm
- ③ Cable diameter min. 6 mm, max. 10 mm, tightening torque  $1.8 \pm 0.3$  Nm (use must be made of seal provided); Cable diameter min. 4 mm, max. 7 mm, tightening torque  $1.8 \pm 0.3$  Nm
- ④ Tightening torque  $1.5 \pm 0.2$  Nm
- ⑤ Inlet ring with pressure tap (k-factor: 381)
- ⑥ Attachment holes for FlowGrid 50710-2-2957 (not included in scope of delivery)

Pin assignment: See connection diagram  
Mounting position: See legend on product drawing

**B** VBS0560CTTPS 8300100535 EC centrifugal fan - RadiPac

Dimensions in mm

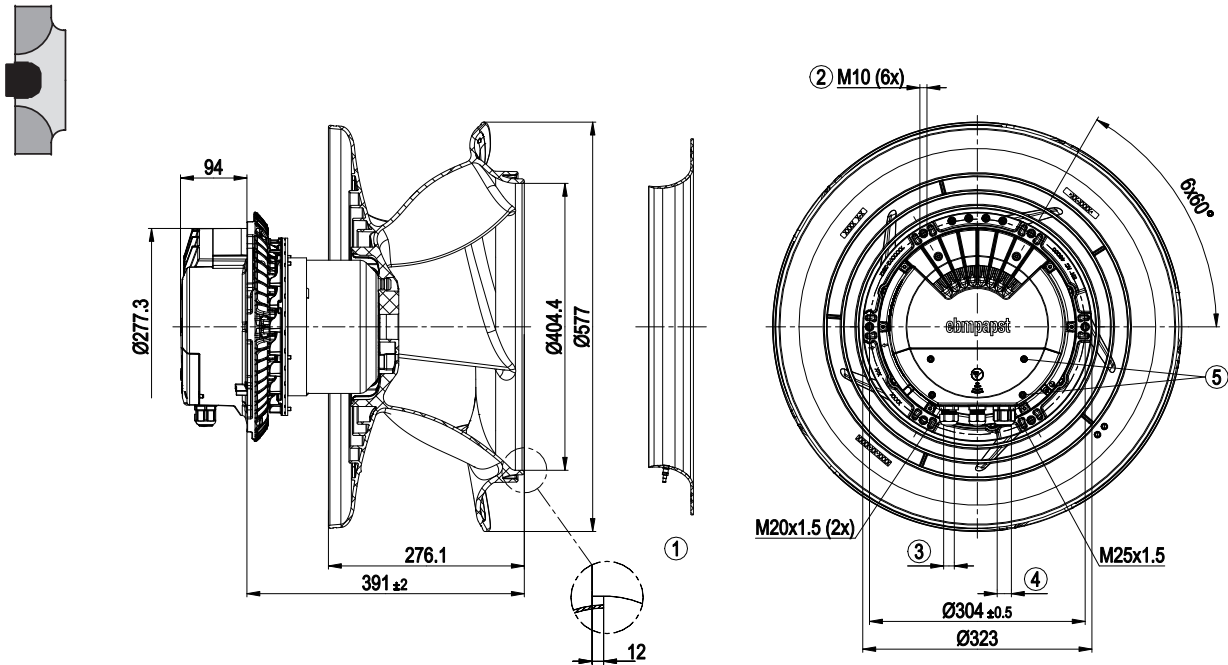

- ① Accessory part: Inlet ring 8217102237 with pressure tap (k-factor: 381) (not included in scope of delivery)
- ② Max. clearance for screw 20 mm
- ③ Cable diameter min. 4 mm, max. 10 mm, tightening torque  $4 \pm 0.6$  Nm
- ④ Cable diameter min. 5 mm, max. 14 mm, tightening torque  $6 \pm 0.9$  Nm  
(The tightening torque is designed for PVC cables. If the cable materials are different, the tightening torque may have to be adjusted)
- ⑤ Tightening torque  $3 \pm 0.3$  Nm

Pin assignment: See connection diagram  
Mounting position: Shaft horizontal or rotor on bottom; rotor on top on request

**B** VBH0560CTTPS 8300100546 EC centrifugal module - RadiPac

Dimensions in mm

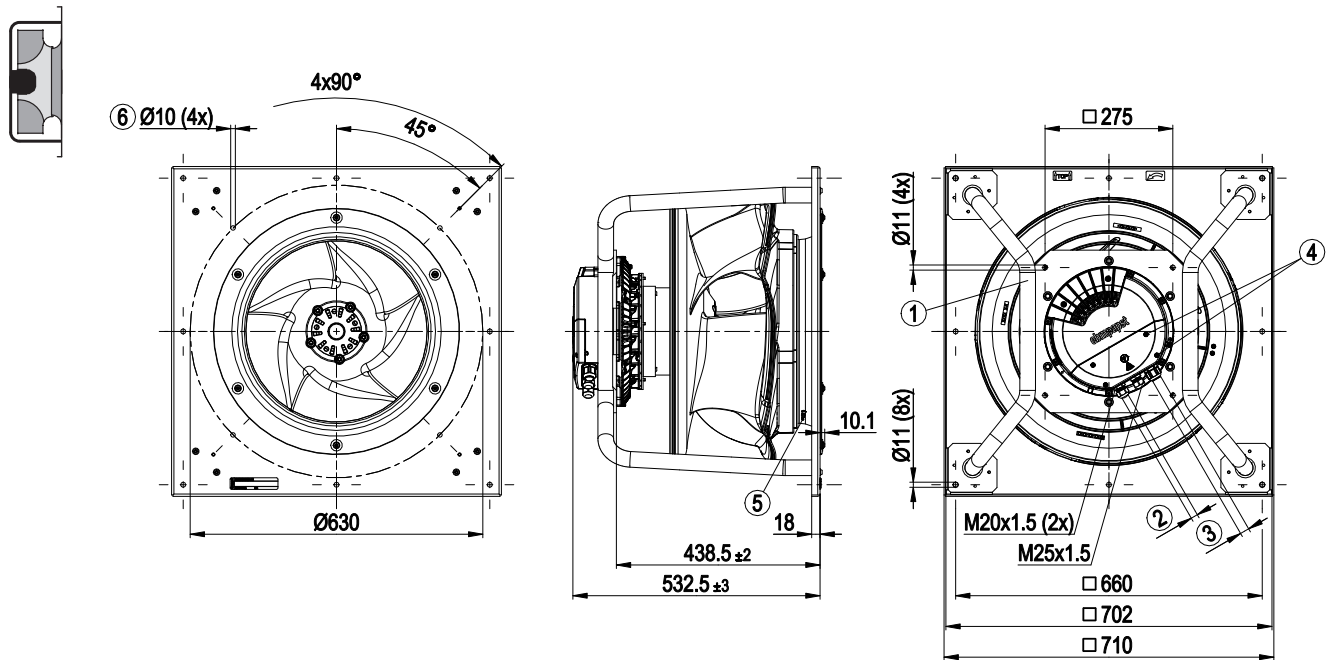

- ① Installed position: shaft horizontal (install support struts only vertically as illustrated) or rotor on bottom; rotor on top on request
- ② Cable diameter min. 4 mm, max. 10 mm, tightening torque  $4 \pm 0.6$  Nm
- ③ Cable diameter min. 5 mm, max. 14 mm, tightening torque  $6 \pm 0.9$  Nm  
(The tightening torque is designed for PVC cables. If the cable materials are different, the tightening torque may have to be adjusted)
- ④ Tightening torque  $3 \pm 0.3$  Nm
- ⑤ Inlet ring with pressure tap (k-factor: 381)
- ⑥ Attachment holes for FlowGrid 50710-2-2957 (not included in scope of delivery)

Pin assignment: See connection diagram  
Mounting position: Shaft horizontal or rotor on bottom; rotor on top on request

# RadiPac 560

C VB0560CTTPS 8300100041 EC centrifugal fan - RadiPac

Dimensions in mm

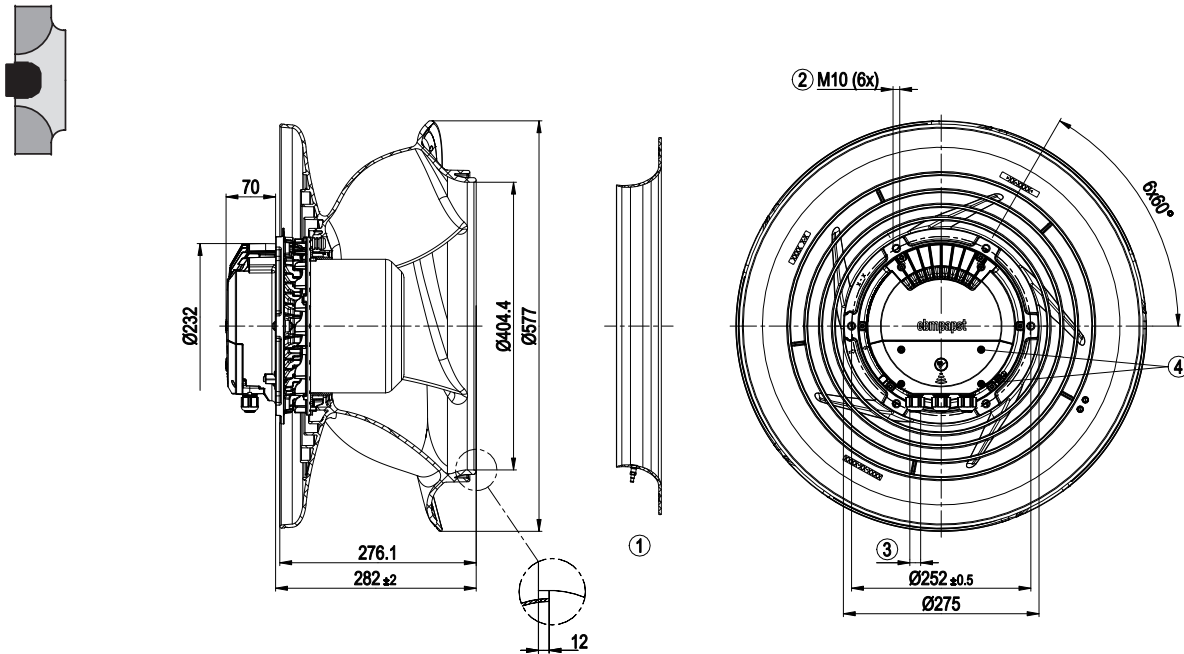

① Accessory part: Inlet ring 8217102237 with pressure tap (k-factor: 381) (not included in scope of delivery)

② Max. clearance for screw 20 mm

③ Cable diameter min. 4 mm, max. 10 mm, tightening torque  $4 \pm 0.6$  Nm

(The tightening torque is designed for PVC cables. If the cable materials are different, the tightening torque may have to be adjusted)

④ Tightening torque  $1.5 \pm 0.2$  Nm

Pin assignment: See connection diagram

Mounting position: Shaft horizontal or rotor on bottom; rotor on top on request

C VBH0560CTTPS 8300100047 EC centrifugal module - RadiPac

Dimensions in mm

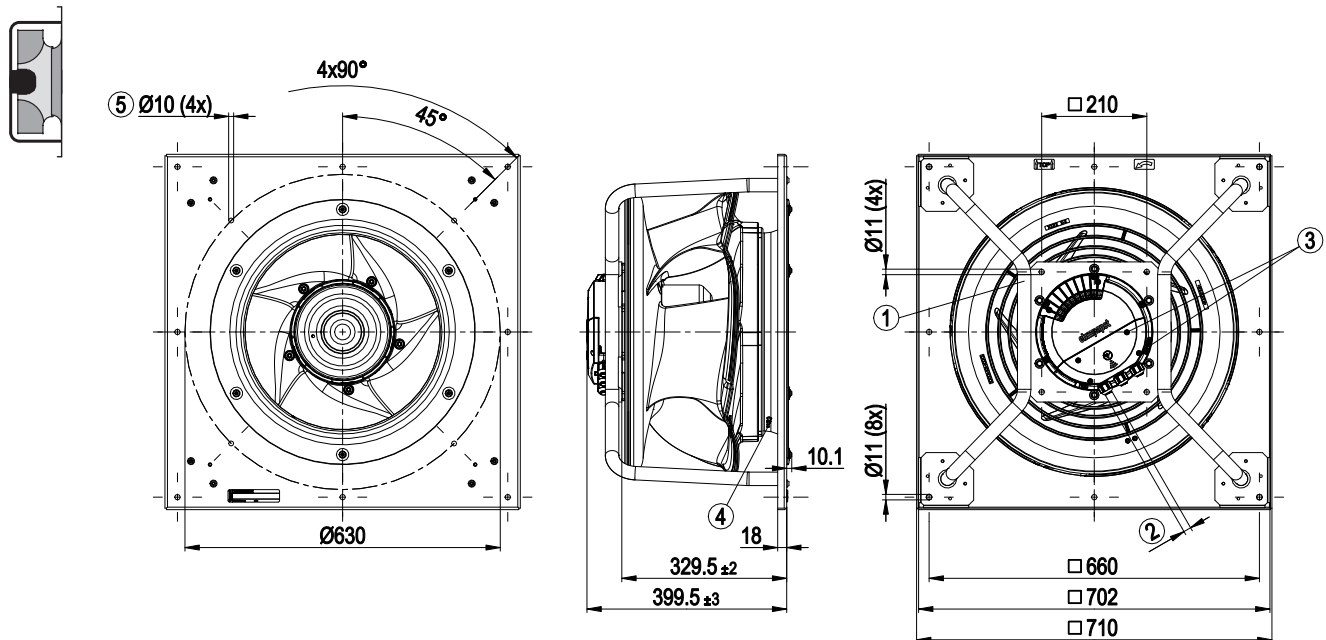

① Installed position: shaft horizontal (install support struts only vertically as illustrated) or rotor on bottom; rotor on top on request

② Cable diameter min. 4 mm, max. 10 mm, tightening torque  $4 \pm 0.6$  Nm

(The tightening torque is designed for PVC cables. If the cable materials are different, the tightening torque may have to be adjusted)

③ Tightening torque  $1.5 \pm 0.2$  Nm

④ Inlet ring with pressure tap (k-factor: 381)

⑤ Attachment holes for FlowGrid 50710-2-2957 (not included in scope of delivery)

Pin assignment: See connection diagram

Mounting position: See legend on product drawing

D VBS0560CTTPS 8300100096 EC centrifugal fan - RadiPac

Dimensions in mm

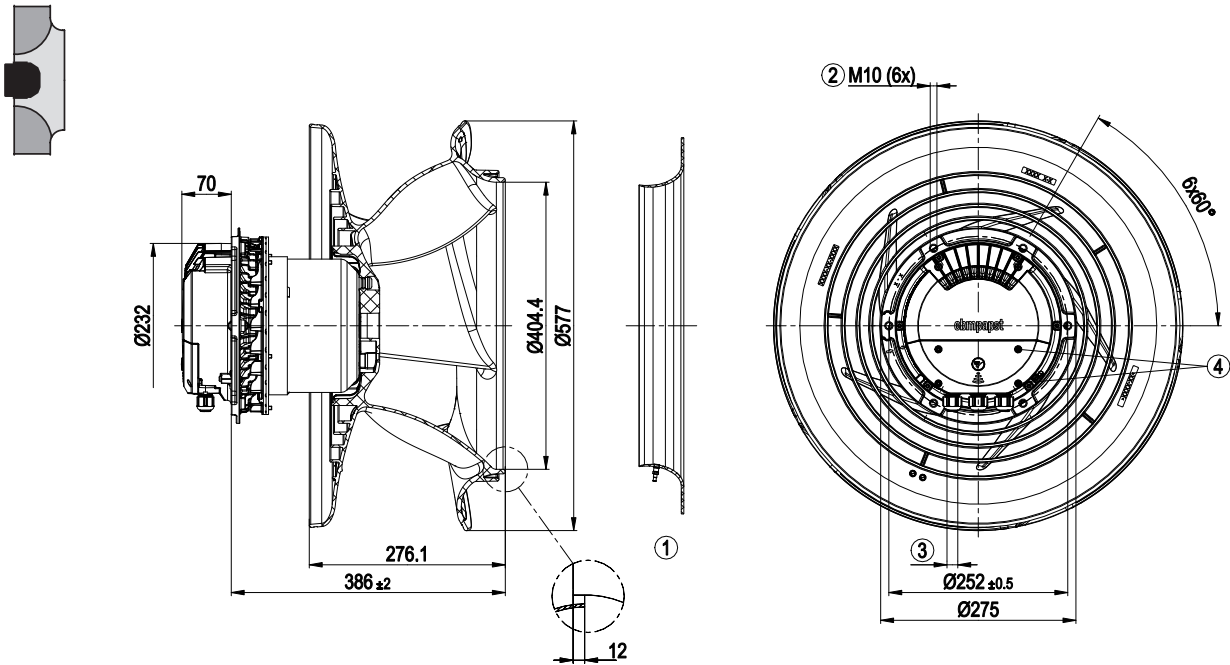

- ① Accessory part: Inlet ring 8217102237 with pressure tap (k-factor: 381) (not included in scope of delivery)
- ② Max. clearance for screw 20 mm
- ③ Cable diameter min. 4 mm, max. 10 mm, tightening torque  $4 \pm 0.6$  Nm  
(The tightening torque is designed for PVC cables. If the cable materials are different, the tightening torque may have to be adjusted)
- ④ Tightening torque  $1.5 \pm 0.2$  Nm

Pin assignment: See connection diagram  
Mounting position: Shaft horizontal or rotor on bottom; rotor on top on request

D VBH0560CTTPS 8300100095 EC centrifugal module - RadiPac

Dimensions in mm

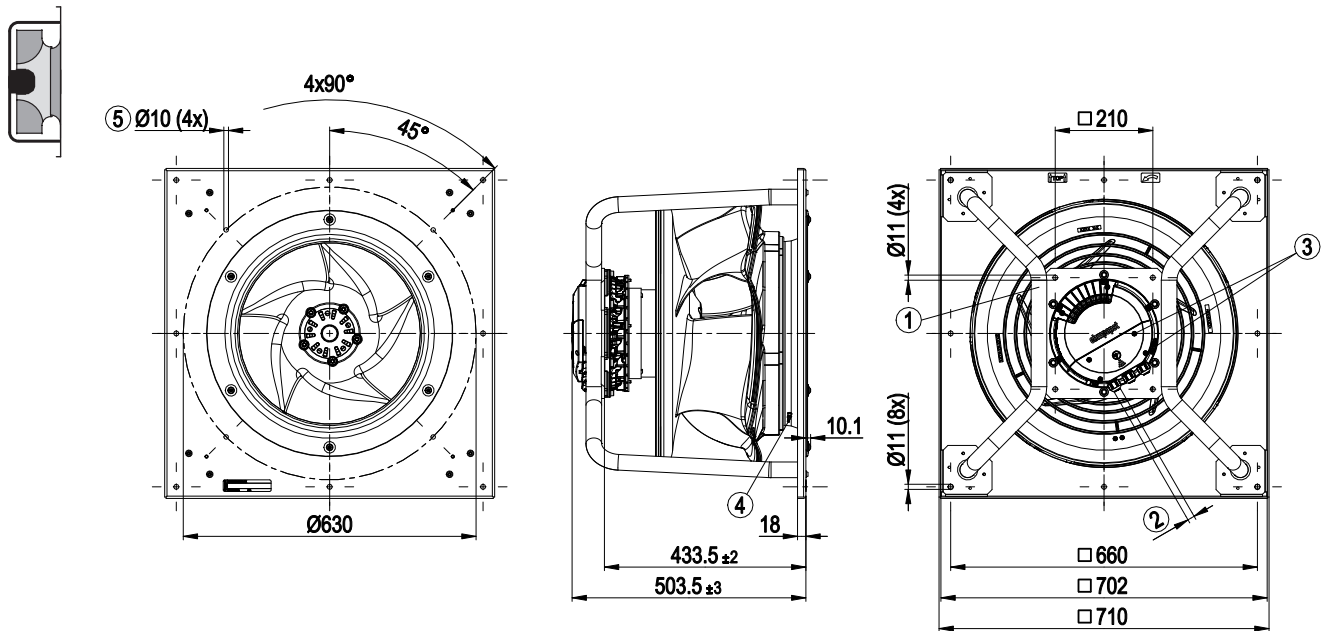

- ① Installed position: shaft horizontal (install support struts only vertically as illustrated) or rotor on bottom; rotor on top on request
- ② Cable diameter min. 4 mm, max. 10 mm, tightening torque  $4 \pm 0.6$  Nm  
(The tightening torque is designed for PVC cables. If the cable materials are different, the tightening torque may have to be adjusted)
- ③ Tightening torque  $1.5 \pm 0.2$  Nm
- ④ Inlet ring with pressure tap (k-factor: 381)
- ⑤ Attachment holes for FlowGrid 50710-2-2957 (not included in scope of delivery)

Pin assignment: See connection diagram  
Mounting position: See legend on product drawing

# RadiPac 560

**E** VBS0560CTTRS 8300100222 EC centrifugal fan - RadiPac

Dimensions in mm

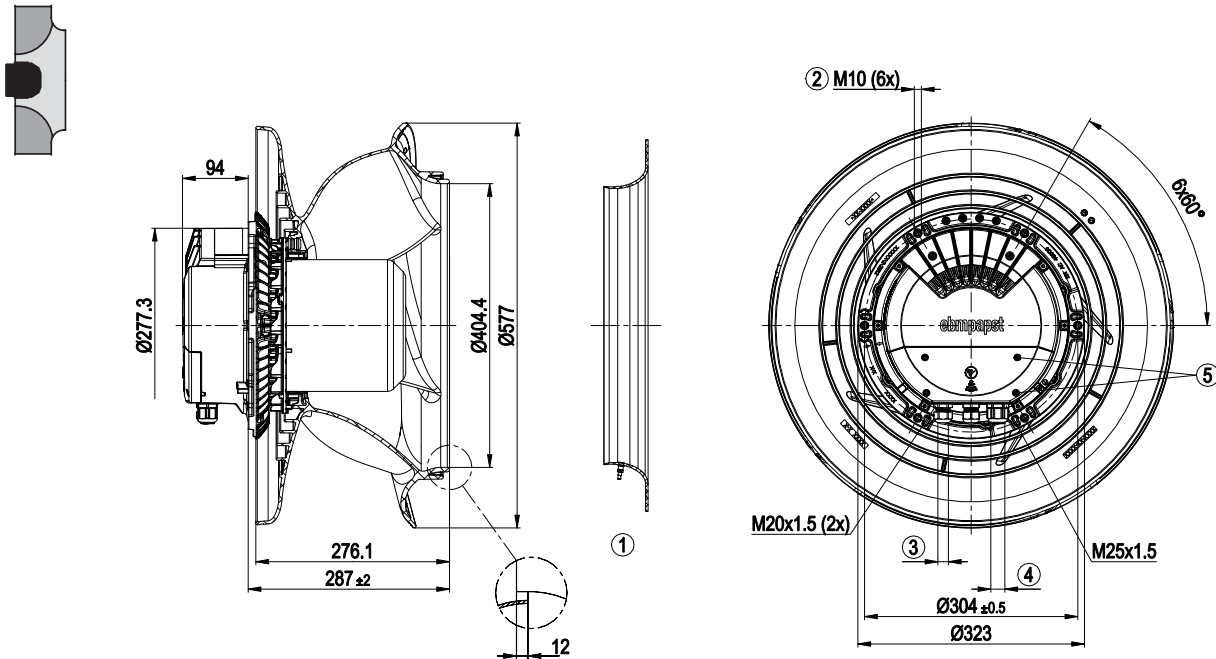

- ① Accessory part: Inlet ring 8217102237 with pressure tap (k-factor: 381) (not included in scope of delivery)
- ② Max. clearance for screw 20 mm
- ③ Cable diameter min. 4 mm, max. 10 mm, tightening torque  $4 \pm 0.6$  Nm
- ④ Cable diameter min. 5 mm, max. 14 mm, tightening torque  $6 \pm 0.9$  Nm  
(The tightening torque is designed for PVC cables. If the cable materials are different, the tightening torque may have to be adjusted)
- ⑤ Tightening torque  $3 \pm 0.3$  Nm

Pin assignment: See connection diagram  
Mounting position: Shaft horizontal or rotor on bottom; rotor on top on request

**E** VBH0560CTTRS 8300100221 EC centrifugal module - RadiPac

Dimensions in mm

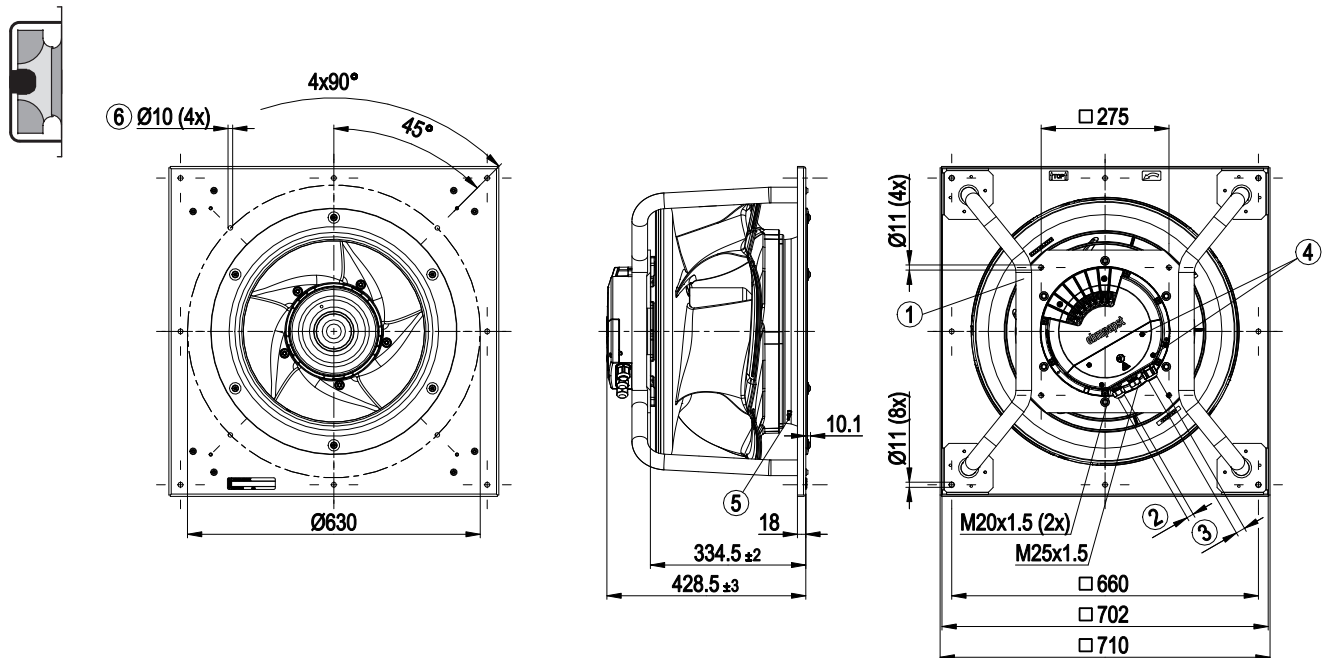

- ① Installed position: shaft horizontal (install support struts only vertically as illustrated) or rotor on bottom; rotor on top on request
- ② Cable diameter min. 4 mm, max. 10 mm, tightening torque  $4 \pm 0.6$  Nm
- ③ Cable diameter min. 5 mm, max. 14 mm, tightening torque  $6 \pm 0.9$  Nm  
(The tightening torque is designed for PVC cables. If the cable materials are different, the tightening torque may have to be adjusted)
- ④ Tightening torque  $3 \pm 0.3$  Nm
- ⑤ Inlet ring with pressure tap (k-factor: 381)
- ⑥ Attachment holes for FlowGrid 50710-2-2957 (not included in scope of delivery)

Pin assignment: See connection diagram  
Mounting position: See legend on product drawing



F VBS0560CTTRS 8300100102 EC centrifugal fan - RadiPac

Dimensions in mm

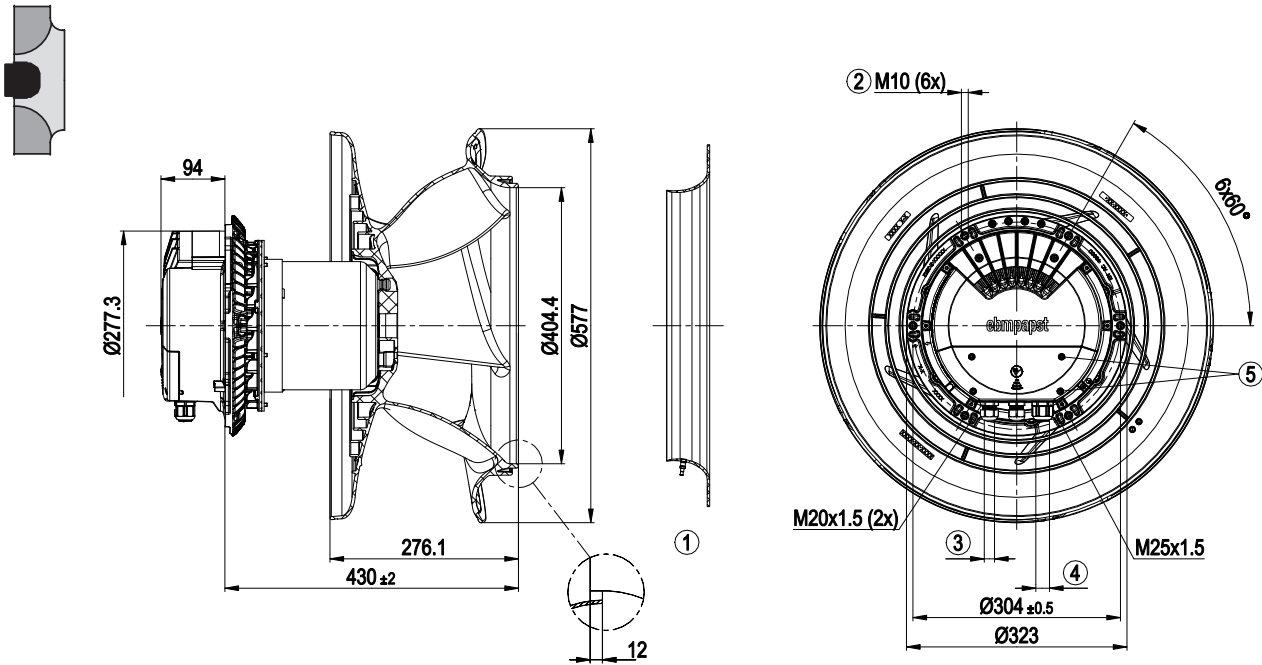

- ① Accessory part: Inlet ring 8217102237 with pressure tap (k-factor: 381) (not included in scope of delivery)
- ② Max. clearance for screw 20 mm
- ③ Cable diameter min. 4 mm, max. 10 mm, tightening torque  $4 \pm 0.6$  Nm
- ④ Cable diameter min. 5 mm, max. 14 mm, tightening torque  $6 \pm 0.9$  Nm  
(The tightening torque is designed for PVC cables. If the cable materials are different, the tightening torque may have to be adjusted)
- ⑤ Tightening torque  $3 \pm 0.3$  Nm

Pin assignment: See connection diagram  
Mounting position: Shaft horizontal or rotor on bottom; rotor on top on request

F VBH0560CTTRS 8300100101 EC centrifugal module - RadiPac

Dimensions in mm

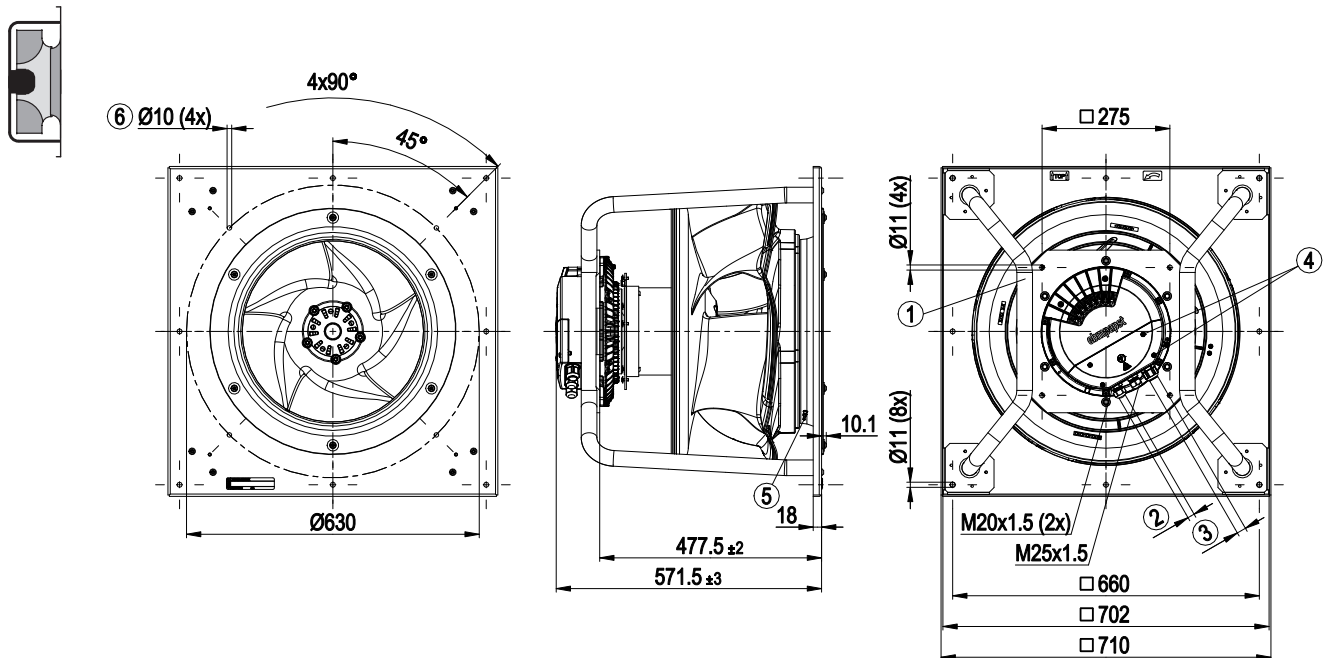

- ① Installed position: shaft horizontal (install support struts only vertically as illustrated) or rotor on bottom; rotor on top on request
- ② Cable diameter min. 4 mm, max. 10 mm, tightening torque  $4 \pm 0.6$  Nm
- ③ Cable diameter min. 5 mm, max. 14 mm, tightening torque  $6 \pm 0.9$  Nm  
(The tightening torque is designed for PVC cables. If the cable materials are different, the tightening torque may have to be adjusted)
- ④ Tightening torque  $3 \pm 0.3$  Nm
- ⑤ Inlet ring with pressure tap (k-factor: 381)
- ⑥ Attachment holes for FlowGrid 50710-2-2957 (not included in scope of delivery)

Pin assignment: See connection diagram  
Mounting position: See legend on product drawing

# RadiPac 630

EC centrifugal fans, backward curved



## Material/Surface

- Support bracket: Steel, painted black
- Support plate: Sheet steel, galvanized
- Inlet nozzle: ABS plastic
- Impeller: PP plastic
- Rotor: Painted black
- Electronics housing: Die-cast aluminum

## Mechanical characteristics

- Number of blades: 5
- Drehrichtung (epM): Clockwise, viewed toward rotor
- Installation position: Shaft horizontal or rotor on bottom; rotor on top on request, See legend on product drawing
- Condensation drainage holes: On rotor side
- Mode: S1
- Motor bearing: Ball bearing

## Additional Information

- Information about touch current, electrical connection, degree of protection, insulation class, environmental protection class, EMC standards as well as standards and approvals can be found in the product-specific data sheets.

from page 84	Drawings
from page 92	Accessories
from page 102	Connection diagrams and technical equipment
from page 110	Environment and general conditions
More at	<a href="http://www.ebmpapst.com/worldwide">www.ebmpapst.com/worldwide</a> <a href="http://www.ebmpapst.com/">www.ebmpapst.com/</a>

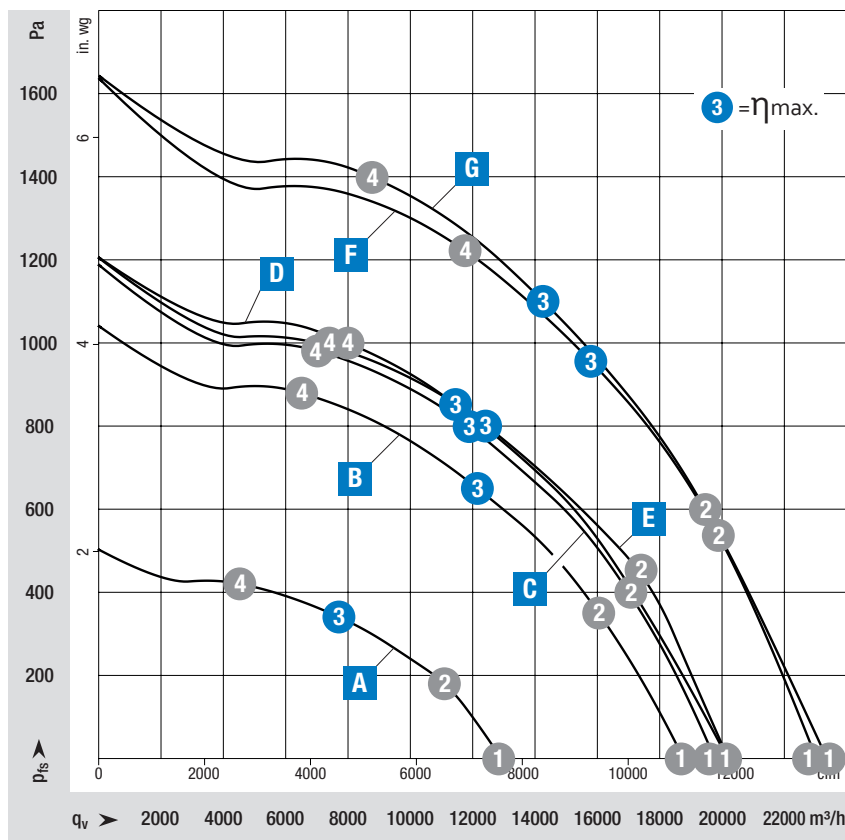









### Measuring conditions

Air performance measured after: ISO 5801, installation category A, with ebm-papst inlet nozzle without contact protection.

Suction-side noise level: LwA according to ISO 13347, LpA measured at a distance of 1 m on the fan axis.

The specifications apply only under the specified measuring conditions and may change due to installation conditions.

In case of deviations from the standard design, the characteristic values must be checked in the installed condition!

Nominal voltage range 3- 380-480 VAC, 50/60 Hz			Characteristic Curve	Operating point	Nominal voltage	Speed n	Max. Input power P <sub>ed</sub>	Max. Input current I	Sound power level L <sub>WA</sub>	Max. back pressure	Perm. ambient temp.	Protection class	Connection diagrams and technical equipment
Type	Part number	Fan type			V	rpm	W	A	dB(A)	Pa	°C		
VBS0630CTRNS	8300100446	Centrifugal fan	 Short-version	A	400	1,060	665	1.05	79				
					400	1,060	981	1.52	74				
					<b>400</b>	<b>1,060</b>	<b>1,070</b>	<b>1.70</b>	<b>68</b>				
					400	1,060	957	1.48	70				
													Page 103
VBH0630CTRNS	8300100447	Support bracket	 Short-version	B	400	1,540	1,934	3.04	89				
					400	1,540	2,818	4.34	82				
					<b>400</b>	<b>1,540</b>	<b>3,150</b>	<b>4.80</b>	<b>79</b>				
					400	1,540	2,829	4.36	81				
													Page 102
VBS0630CTTPS	8300100060	Centrifugal fan	 Short-version	C	400	1,670	2,495	3.87	91				
					400	1,670	3,461	5.30	84				
					<b>400</b>	<b>1,670</b>	<b>3,900</b>	<b>6.00</b>	<b>80</b>				
					400	1,670	3,646	5.58	82				
													Page 102
VBH0630CTTPS	8300100057	Support bracket	 Short-version	D	400	1,630	2,241	3.49	90				
					400	1,630	3,328	5.11	83				
					<b>400</b>	<b>1,630</b>	<b>3,720</b>	<b>5.70</b>	<b>77</b>				
					400	1,630	3,320	5.09	81				
													Page 102
VBS0630CTTPS	8300100544	Centrifugal fan	 Long-version PFC-active	E	400	1,650	2,451	3.55	93				
					400	1,650	3,603	5.21	86				
					<b>400</b>	<b>1,650</b>	<b>4,000</b>	<b>5.80</b>	<b>78</b>				
					400	1,650	3,531	5.11	82				
													Page 104
VBH0630CTTPS	8300100545	Support bracket	 Long-version PFC-active	F	400	1,910	3,470	5.56	94				
					400	1,910	5,155	7.99	88				
					<b>400</b>	<b>1,910</b>	<b>5,850</b>	<b>9.00</b>	<b>83</b>				
					400	1,910	5,755	8.83	83				
													Page 102
VBS0630CTTRS	8300100218	Centrifugal fan	 Short-version	G	400	1,950	4,449	6.96	102				
					400	1,950	5,883	9.07	93				
					<b>400</b>	<b>1,950</b>	<b>6,400</b>	<b>9.80</b>	<b>86</b>				
					400	1,950	5,884	9.07	89				
													Page 102
VBH0630CTTRS	8300100217	Support bracket	 Short-version		400	1,950	4,449	6.96	102				
					400	1,950	5,883	9.07	93				
					<b>400</b>	<b>1,950</b>	<b>6,400</b>	<b>9.80</b>	<b>86</b>				
					400	1,950	5,884	9.07	89				
													Page 102

Subject to changes.

Values set in blue are nominal data at the operating point at maximum load.

# RadiPac 630

**A** VBS0630CTRNS 8300100446 EC centrifugal fan - RadiPac

Dimensions in mm

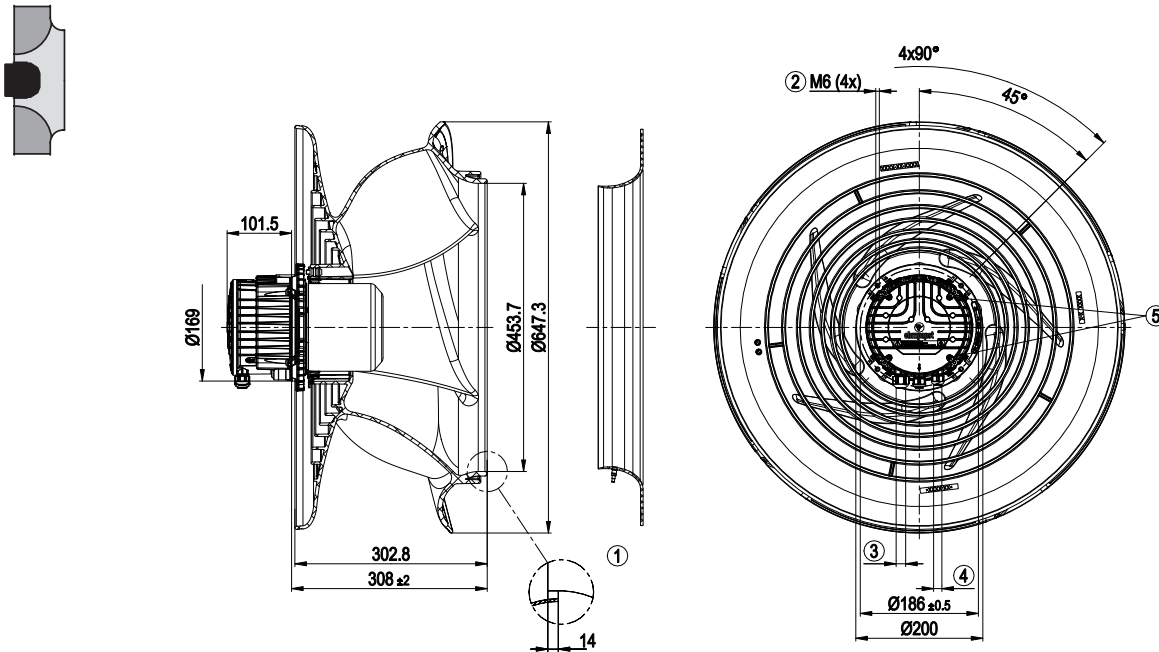

- ① Accessory part: Inlet ring 8217102238 with pressure tap (k-factor: 290) (not included in scope of delivery)
- ② Max. clearance for screw 16 mm
- ③ Cable diameter min. 8 mm, max. 12 mm, tightening torque 1.8±0.3 Nm (use must be made of seal provided); Cable diameter min. 4 mm, max. 10 mm, tightening torque 1.8±0.3 Nm
- ④ Cable diameter min. 6 mm, max. 10 mm, tightening torque 1.8±0.3 Nm (use must be made of seal provided); Cable diameter min. 4 mm, max. 7 mm, tightening torque 1.8±0.3 Nm
- ⑤ Tightening torque 1.5 ± 0.2 Nm

Pin assignment: See connection diagram  
Mounting position: Shaft horizontal or rotor on bottom; rotor on top on request

**A** VBH0630CTRNS 8300100447 EC centrifugal module - RadiPac

Dimensions in mm

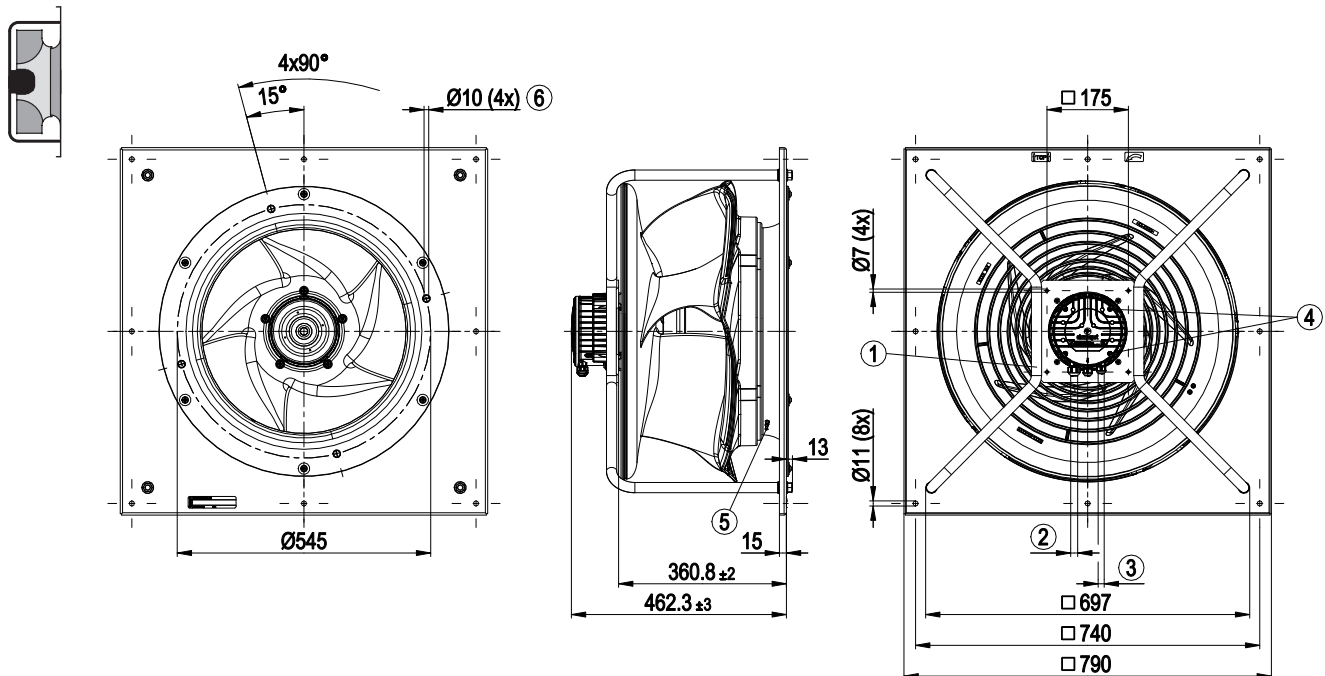

- ① Installed position: shaft horizontal (install support struts only vertically as illustrated) or rotor on bottom; rotor on top on request
- ② Cable diameter min. 8 mm, max. 12 mm, tightening torque 1.8±0.3 Nm (use must be made of seal provided); Cable diameter min. 4 mm, max. 10 mm, tightening torque 1.8±0.3 Nm
- ③ Cable diameter min. 6 mm, max. 10 mm, tightening torque 1.8±0.3 Nm (use must be made of seal provided); Cable diameter min. 4 mm, max. 7 mm, tightening torque 1.8±0.3 Nm
- ④ Tightening torque 1.5 ± 0.2 Nm
- ⑤ Inlet ring with pressure tap (k-factor: 463)
- ⑥ Fastening holes for FlowGrid 00630-2-2957 (not included in scope of delivery) are provided and must be subsequently opened as required

Pin assignment: See connection diagram  
Mounting position: See legend on product drawing

## B VBS0630CTTLS 8300100092 EC centrifugal fan - RadiPac

Dimensions in mm

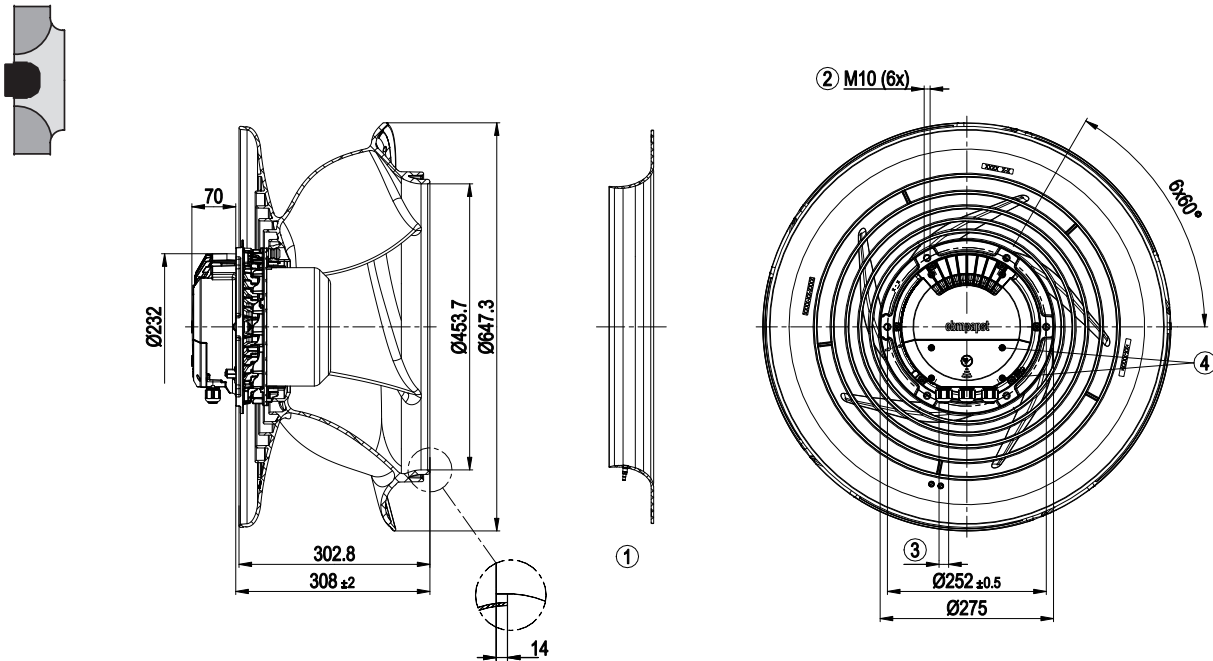

- ① Accessory part: Inlet ring 8217102236 with pressure tap (k-factor: 463) (not included in scope of delivery)
- ② Max. clearance for screw 20 mm
- ③ Cable diameter min. 4 mm, max. 10 mm, tightening torque  $4 \pm 0.6$  Nm  
(The tightening torque is designed for PVC cables. If the cable materials are different, the tightening torque may have to be adjusted)
- ④ Tightening torque  $1.5 \pm 0.2$  Nm

Pin assignment: See connection diagram  
Mounting position: Shaft horizontal or rotor on bottom; rotor on top on request

## B VBH0630CTTLS 8300100091 EC centrifugal module - RadiPac

Dimensions in mm

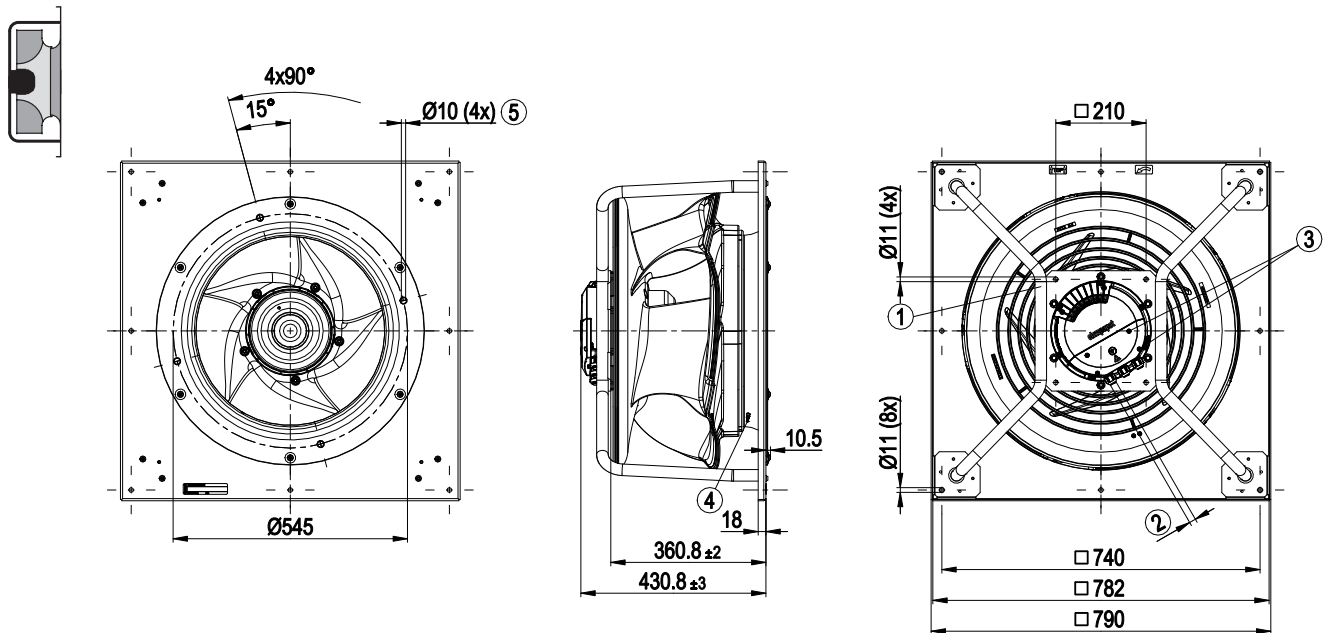

- ① Installed position: shaft horizontal (install support struts only vertically as illustrated) or rotor on bottom; rotor on top on request
- ② Cable diameter min. 4 mm, max. 10 mm, tightening torque  $4 \pm 0.6$  Nm  
(The tightening torque is designed for PVC cables. If the cable materials are different, the tightening torque may have to be adjusted)
- ③ Tightening torque  $1.5 \pm 0.2$  Nm
- ④ Inlet ring with pressure tap (k-factor: 463)
- ⑤ Fastening holes for FlowGrid 00630-2-2957 (not included in scope of delivery) are provided and must be subsequently opened as required

Pin assignment: See connection diagram  
Mounting position: See legend on product drawing

# RadiPac 630

C VBS0630CTTPS 8300100060 EC centrifugal fan - RadiPac

Dimensions in mm

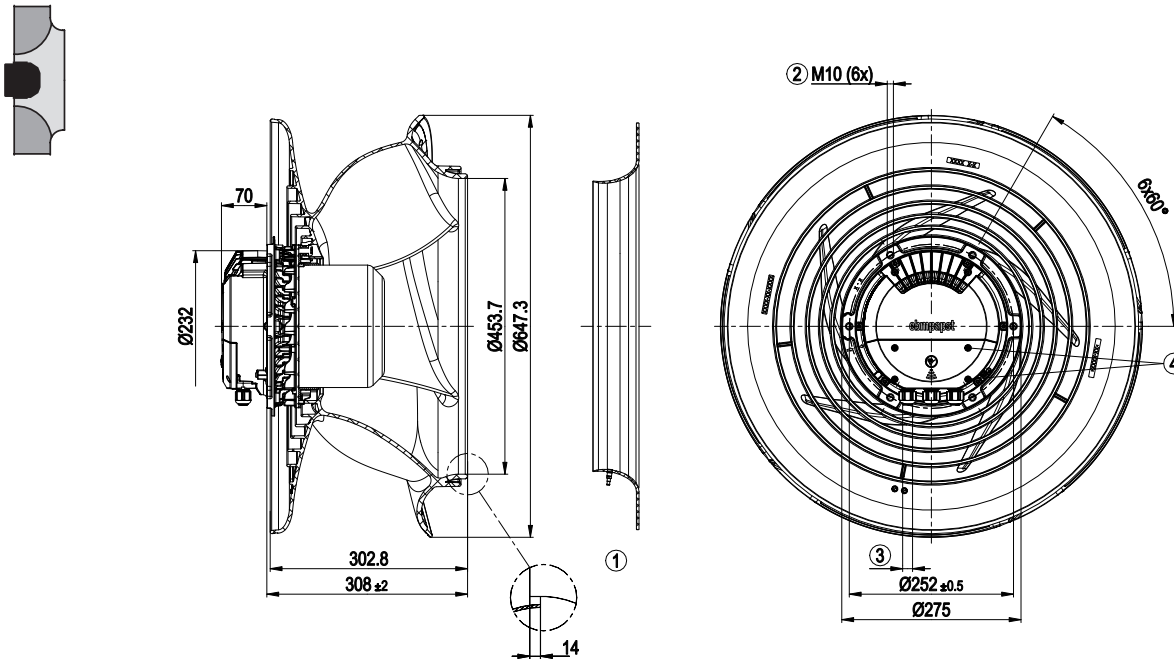

- ① Accessory part: Inlet ring 8217102236 with pressure tap (k-factor: 463) (not included in scope of delivery)
- ② Max. clearance for screw 20 mm
- ③ Cable diameter min. 4 mm, max. 10 mm, tightening torque  $4 \pm 0.6$  Nm  
(The tightening torque is designed for PVC cables. If the cable materials are different, the tightening torque may have to be adjusted)
- ④ Tightening torque  $1.5 \pm 0.2$  Nm

Pin assignment: See connection diagram  
Mounting position: Shaft horizontal or rotor on bottom; rotor on top on request

C VBH0630CTTPS 8300100057 EC centrifugal module - RadiPac

Dimensions in mm

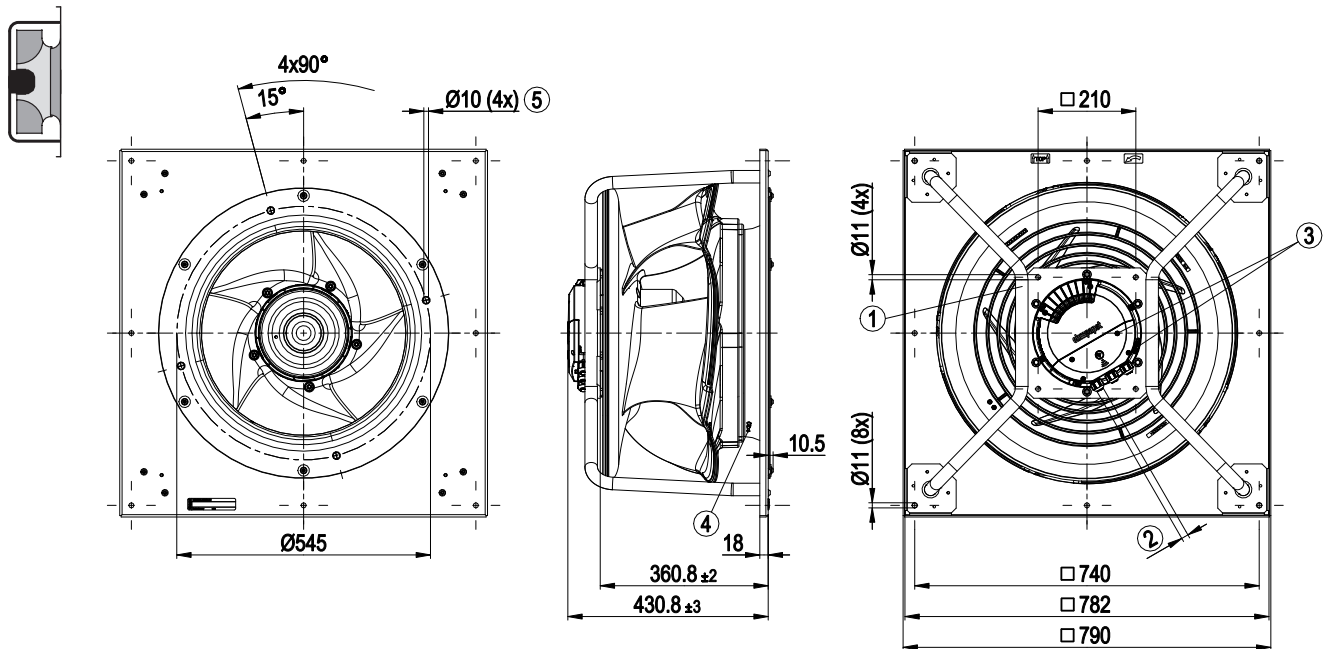

- ① Installed position: shaft horizontal (install support struts only vertically as illustrated) or rotor on bottom; rotor on top on request
- ② Cable diameter min. 4 mm, max. 10 mm, tightening torque  $4 \pm 0.6$  Nm  
(The tightening torque is designed for PVC cables. If the cable materials are different, the tightening torque may have to be adjusted)
- ③ Tightening torque  $1.5 \pm 0.2$  Nm
- ④ Inlet ring with pressure tap (k-factor: 463)
- ⑤ Fastening holes for FlowGrid 00630-2-2957 (not included in scope of delivery) are provided and must be subsequently opened as required

Pin assignment: See connection diagram  
Mounting position: See legend on product drawing

## D VBS0630CTTPS 8300100093 EC centrifugal fan - RadiPac

Dimensions in mm

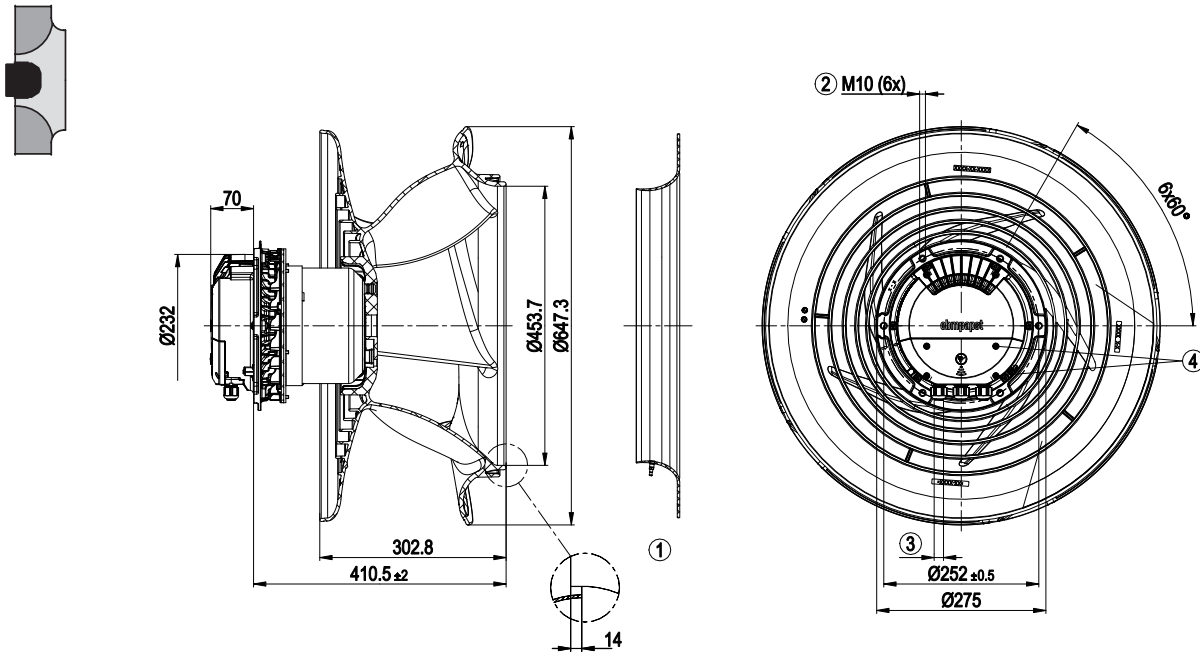

- ① Accessory part: Inlet ring 8217102236 with pressure tap (k-factor: 463) (not included in scope of delivery)
- ② Max. clearance for screw 20 mm
- ③ Cable diameter min. 4 mm, max. 10 mm, tightening torque  $4 \pm 0.6$  Nm  
(The tightening torque is designed for PVC cables. If the cable materials are different, the tightening torque may have to be adjusted)
- ④ Tightening torque  $1.5 \pm 0.2$  Nm

Pin assignment: See connection diagram  
Mounting position: Shaft horizontal or rotor on bottom; rotor on top on request

## D VBH0630CTTPS 8300100094 EC centrifugal module - RadiPac

Dimensions in mm

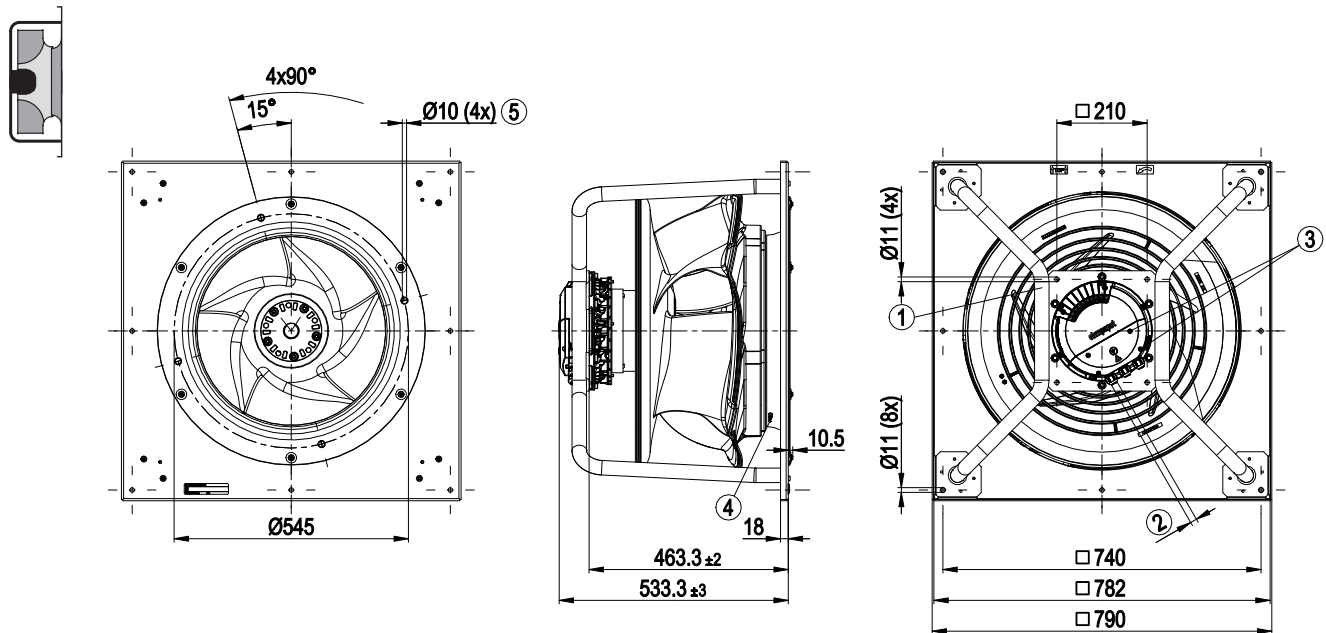

- ① Installed position: shaft horizontal (install support struts only vertically as illustrated) or rotor on bottom; rotor on top on request
- ② Cable diameter min. 4 mm, max. 10 mm, tightening torque  $4 \pm 0.6$  Nm  
(The tightening torque is designed for PVC cables. If the cable materials are different, the tightening torque may have to be adjusted)
- ③ Tightening torque  $1.5 \pm 0.2$  Nm
- ④ Inlet ring with pressure tap (k-factor: 463)
- ⑤ Fastening holes for FlowGrid 00630-2-2957 (not included in scope of delivery) are provided and must be subsequently opened as required

Pin assignment: See connection diagram  
Mounting position: See legend on product drawing

# RadiPac 630

**E** VBS0630CTTPS 8300100544 EC centrifugal fan - RadiPac

Dimensions in mm

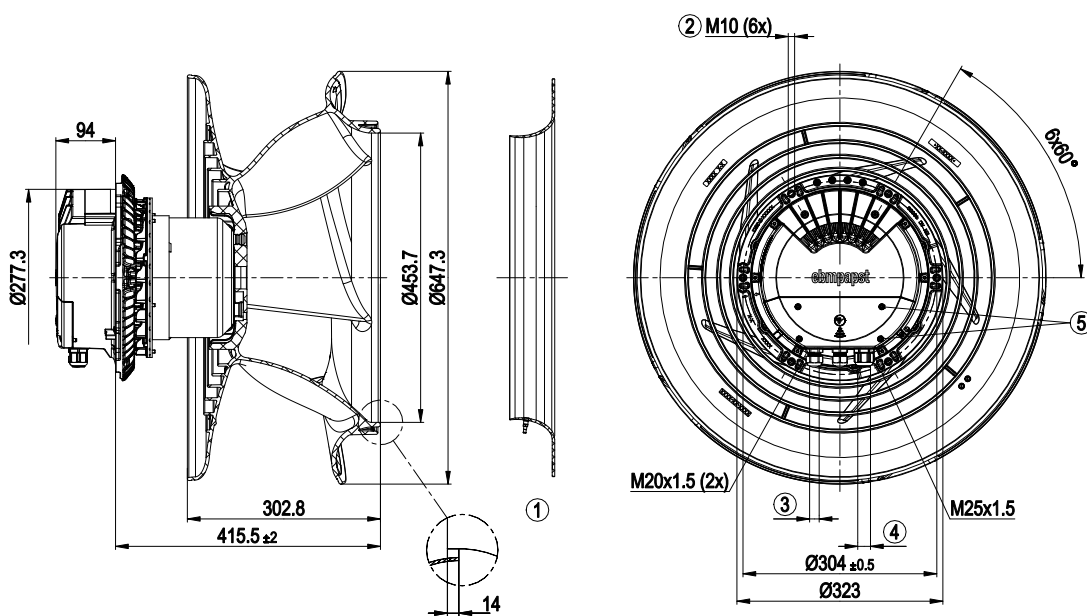

- ① Accessory part: Inlet ring 8217102236 with pressure tap (k-factor: 463) (not included in scope of delivery)
- ② Max. clearance for screw 20 mm
- ③ Cable diameter min. 4 mm, max. 10 mm, tightening torque  $4 \pm 0.6$  Nm
- ④ Cable diameter min. 5 mm, max. 14 mm, tightening torque  $6 \pm 0.9$  Nm  
(The tightening torque is designed for PVC cables. If the cable materials are different, the tightening torque may have to be adjusted)
- ⑤ Tightening torque  $3 \pm 0.3$  Nm

Pin assignment: See connection diagram  
Mounting position: Shaft horizontal or rotor on bottom; rotor on top on request

**E** VBH0630CTTPS 8300100545 EC centrifugal module - RadiPac

Dimensions in mm

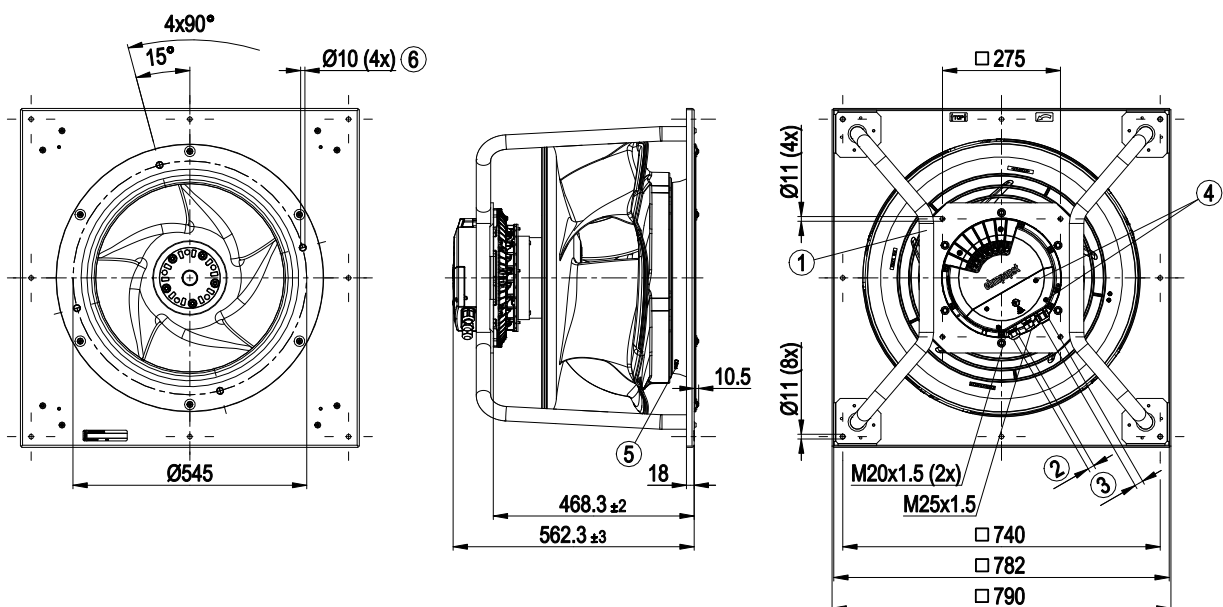

- ① Installed position: shaft horizontal (install support struts only vertically as illustrated) or rotor on bottom; rotor on top on request
- ② Cable diameter min. 4 mm, max. 10 mm, tightening torque  $4 \pm 0.6$  Nm
- ③ Cable diameter min. 5 mm, max. 14 mm, tightening torque  $6 \pm 0.9$  Nm  
(The tightening torque is designed for PVC cables. If the cable materials are different, the tightening torque may have to be adjusted)
- ④ Tightening torque  $3 \pm 0.3$  Nm
- ⑤ Inlet ring with pressure tap (k-factor: 463)
- ⑥ Fastening holes for FlowGrid 00630-2-2957 (not included in scope of delivery) are provided and must be subsequently opened as required

Pin assignment: See connection diagram  
Mounting position: Shaft horizontal or rotor on bottom; rotor on top on request



## F VBS0630CTTRS 8300100045 EC centrifugal fan - RadiPac

Dimensions in mm

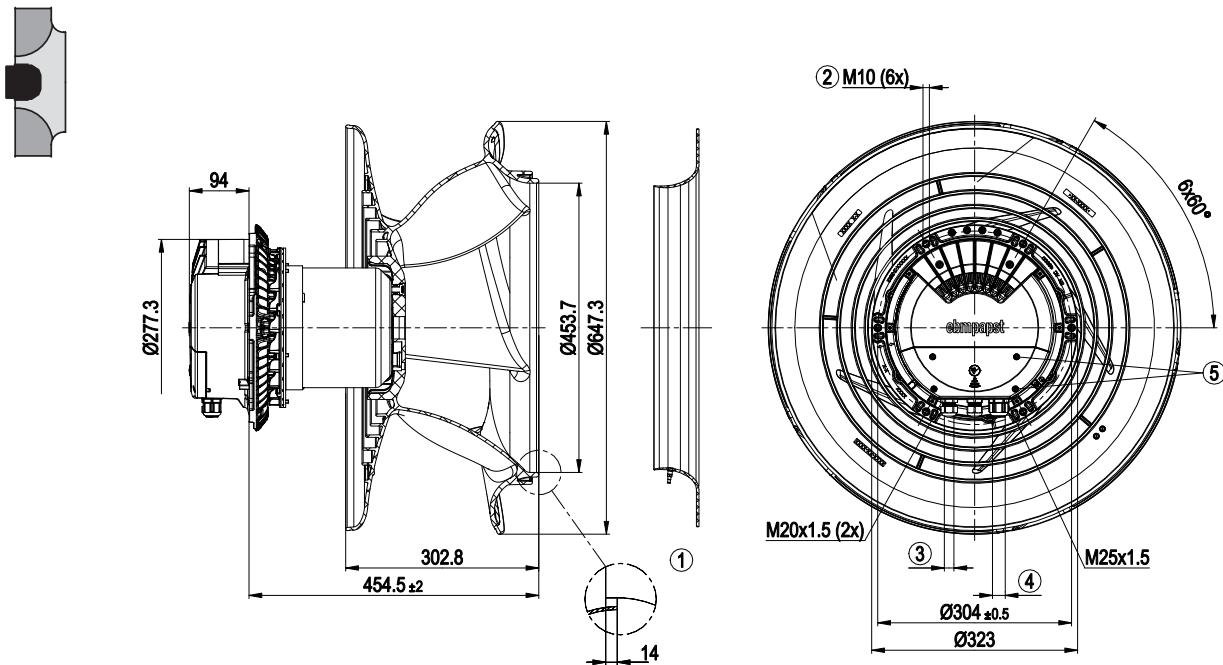

- ① Accessory part: Inlet ring 8217102236 with pressure tap (k-factor: 463) (not included in scope of delivery)
- ② Max. clearance for screw 20 mm
- ③ Cable diameter min. 4 mm, max. 10 mm, tightening torque  $4 \pm 0.6$  Nm
- ④ Cable diameter min. 5 mm, max. 14 mm, tightening torque  $6 \pm 0.9$  Nm  
(The tightening torque is designed for PVC cables. If the cable materials are different, the tightening torque may have to be adjusted)
- ⑤ Tightening torque  $3 \pm 0.3$  Nm

Pin assignment: See connection diagram  
Mounting position: Shaft horizontal or rotor on bottom; rotor on top on request

## F VBH0630CTTRS 8300100048 EC centrifugal module - RadiPac

Dimensions in mm

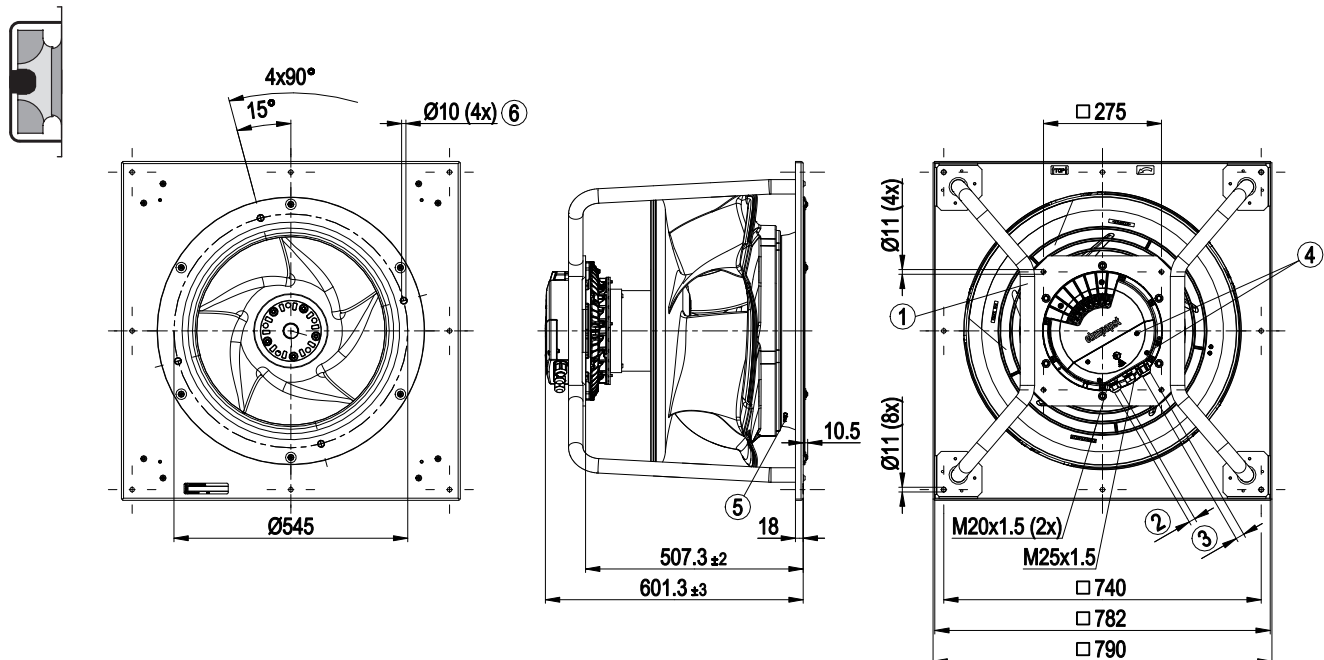

- ① Installed position: shaft horizontal (install support struts only vertically as illustrated) or rotor on bottom; rotor on top on request
- ② Cable diameter min. 4 mm, max. 10 mm, tightening torque  $4 \pm 0.6$  Nm
- ③ Cable diameter min. 5 mm, max. 14 mm, tightening torque  $6 \pm 0.9$  Nm  
(The tightening torque is designed for PVC cables. If the cable materials are different, the tightening torque may have to be adjusted)
- ④ Tightening torque  $3 \pm 0.3$  Nm
- ⑤ Inlet ring with pressure tap (k-factor: 463)
- ⑥ Fastening holes for FlowGrid 00630-2-2957 (not included in scope of delivery) are provided and must be subsequently opened as required

Pin assignment: See connection diagram  
Mounting position: See legend on product drawing

# RadiPac 630

G VBS0630CTTRS 8300100218 EC centrifugal fan - RadiPac

Dimensions in mm

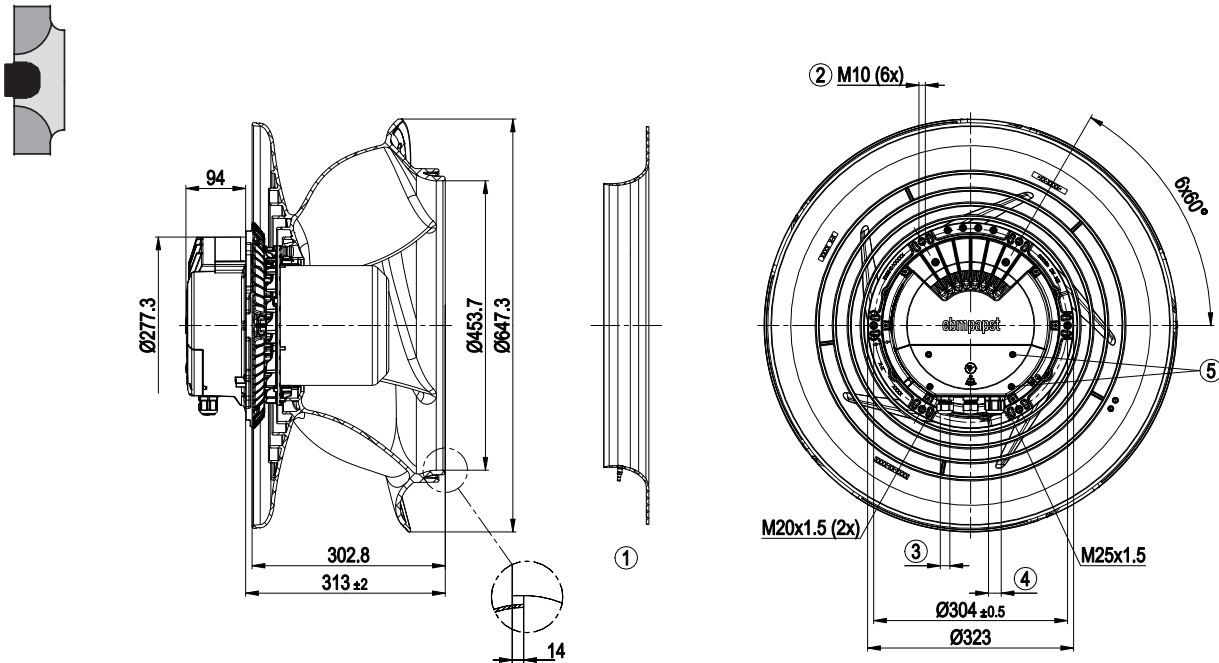

- ① Accessory part: Inlet ring 8217102236 with pressure tap (k-factor: 463) (not included in scope of delivery)
- ② Max. clearance for screw 20 mm
- ③ Cable diameter min. 4 mm, max. 10 mm, tightening torque  $4 \pm 0.6$  Nm
- ④ Cable diameter min. 5 mm, max. 14 mm, tightening torque  $6 \pm 0.9$  Nm  
(The tightening torque is designed for PVC cables. If the cable materials are different, the tightening torque may have to be adjusted)
- ⑤ Tightening torque  $3 \pm 0.3$  Nm

Pin assignment: See connection diagram  
Mounting position: Shaft horizontal or rotor on bottom; rotor on top on request

G VBH0630CTTRS 8300100217 EC centrifugal module - RadiPac

Dimensions in mm

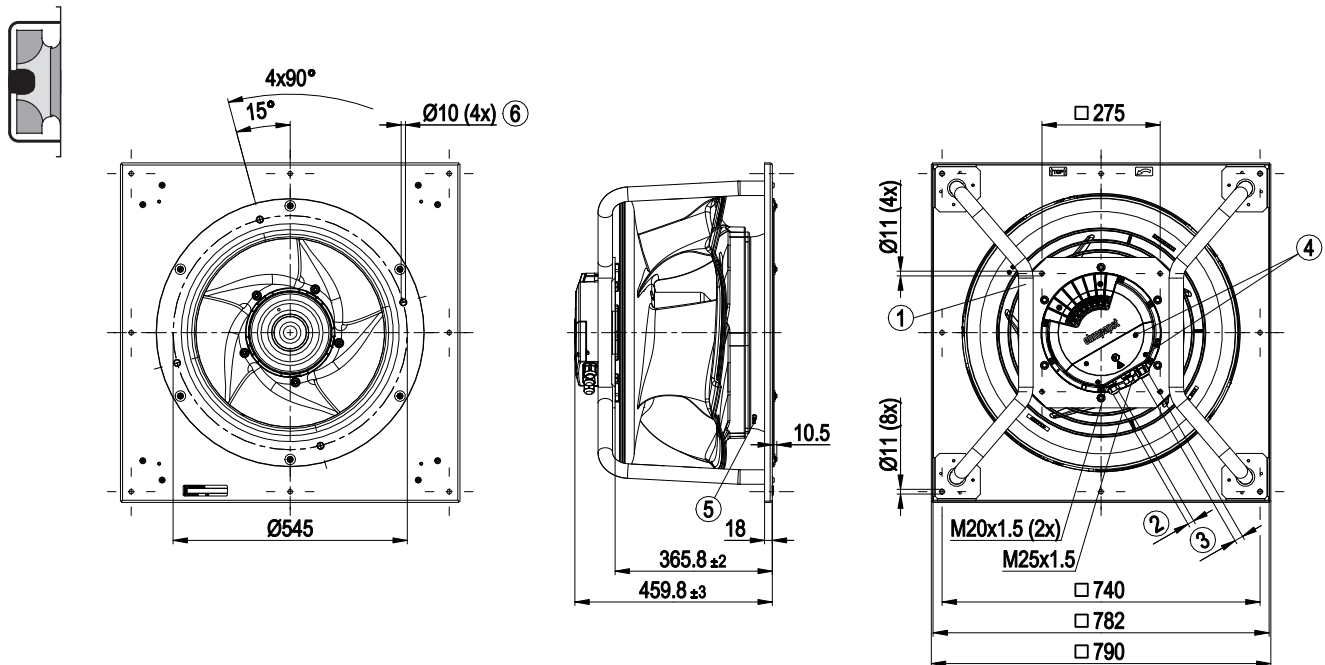

- ① Installed position: shaft horizontal (install support struts only vertically as illustrated) or rotor on bottom; rotor on top on request
- ② Cable diameter min. 4 mm, max. 10 mm, tightening torque  $4 \pm 0.6$  Nm
- ③ Cable diameter min. 5 mm, max. 14 mm, tightening torque  $6 \pm 0.9$  Nm  
(The tightening torque is designed for PVC cables. If the cable materials are different, the tightening torque may have to be adjusted)
- ④ Tightening torque  $3 \pm 0.3$  Nm
- ⑤ Inlet ring with pressure tap (k-factor: 463)
- ⑥ Fastening holes for FlowGrid 00630-2-2957 (not included in scope of delivery) are provided and must be subsequently opened as required

Pin assignment: See connection diagram  
Mounting position: See legend on product drawing



*ebm-papst*

# EC centrifugal fans & modules

## RadiPac - C Accesories

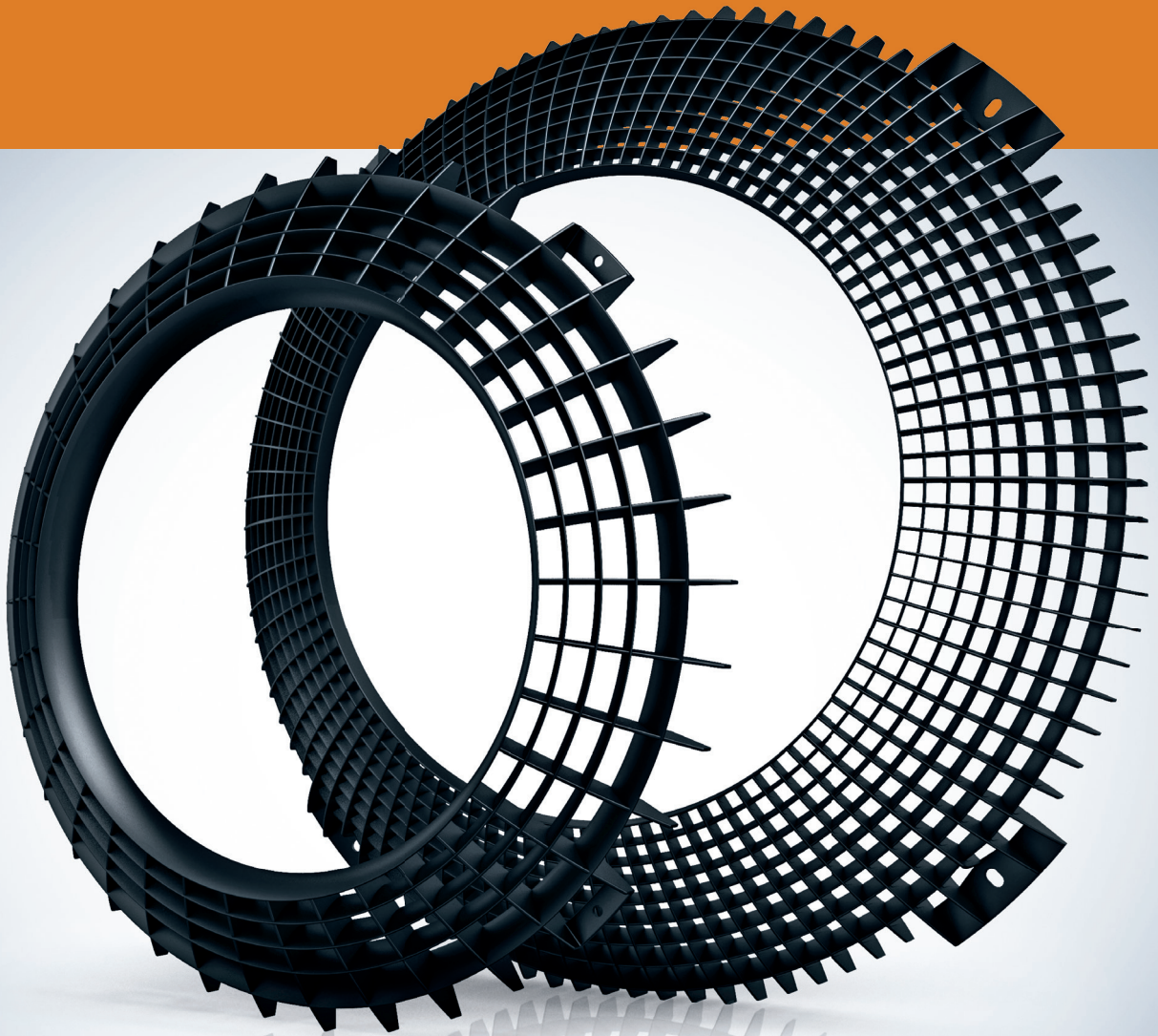

**ebmpapst**

engineering a better life

# Accessories 280 - 630

	Page
FlowGrid air inlet grill	94
Guard grille	95
Inlet rings	96

# FlowGrid air inlet grill

efficient noise reduction



ebm-papst fans are not measured on our own advanced test stands just for their air performance alone. The acoustic behavior of the fans is also examined and the measurement results are included in the technical documentation.

Please note that the measurements are taken under ideal conditions with undisturbed inflow and out-flow. If the fans are subsequently installed and used in devices with rather tight spaces, it is to be expected that the noise data provided in the documentation will not be applicable.

In order to minimize the negative impact of the installation situation, ebm-papst offers the FlowGrid air-inlet guard shown here. It is installed on the intake side of the fan and effectively reduces the noise generated by the fan. Particularly annoying, low-frequency noises are reduced efficiently.

The level of noise reduction is dependent on the installation situation, which is why no generally applicable data is possible here.

## FlowGrid air inlet grill

Part number	Fan size	Ø B (mm)	Ø C (mm)	Ø E (mm)	S (mm)	H (mm)	N* (Nm)
20280-2-2957	280	280	244-260	4,5	3,5	40	2±0,5
25310-2-2957	310	315	288-292	5,5	3,5	49	2±0,5
00400-2-2957	355, 400	370	334-346	4,5	3,5	56	2±0,5
35505-2-2957	450, 500	470	440	9,0	3,5	71	10±2
50710-2-2957	560	666	630	10	3,0	106	10±2
00630-2-2957	630	580	545	10	3,0	90	10±2

Subject to changes.

\* Recommended tightening torque for fastening screws

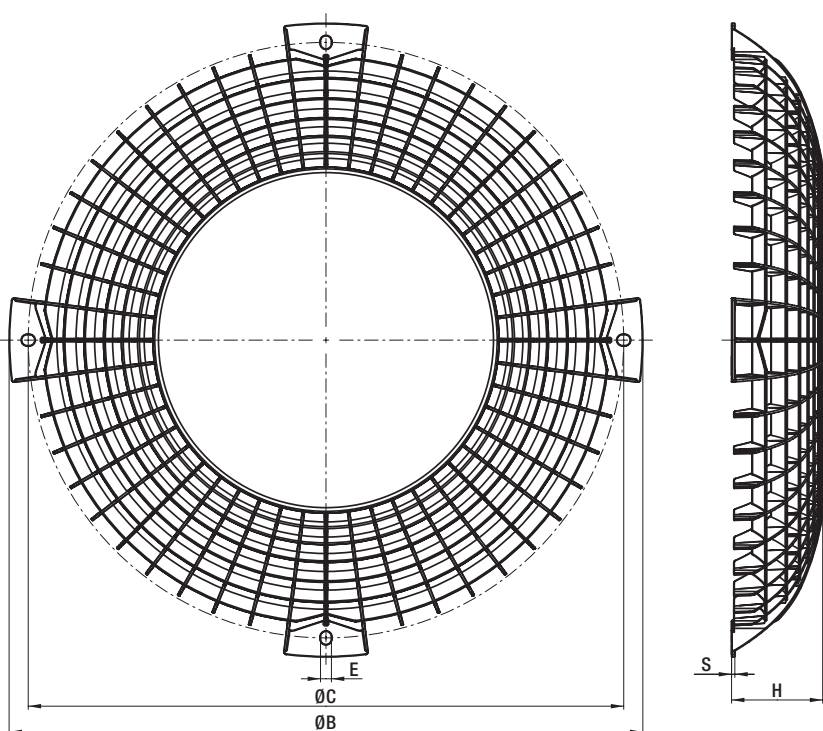

### Would you like to find out more?

If you need an installation guide or more information about the dimensions, go to:

[www.ebmpapst.com/flowgrid-manual](http://www.ebmpapst.com/flowgrid-manual)

or scan the QR code below:



# Guard grille

RadiPac - C



– **Material:** Steel, black plastic coated

– **Mounting:** The guard grille is easily mounted by means of 4 clamping devices clipped onto the FlowGrid.

## Guard grille for EC centrifugal fans - RadiPac - C

Part number	Fan size	FlowGrid assignment
---	280	not available
---	310	not available
8217102438	355, 400	00400-2-2957
8217102439	450, 500	35505-2-2957
8217102436	560	50710-2-2957
8217102437	630	00630-2-2957

Subject to changes.

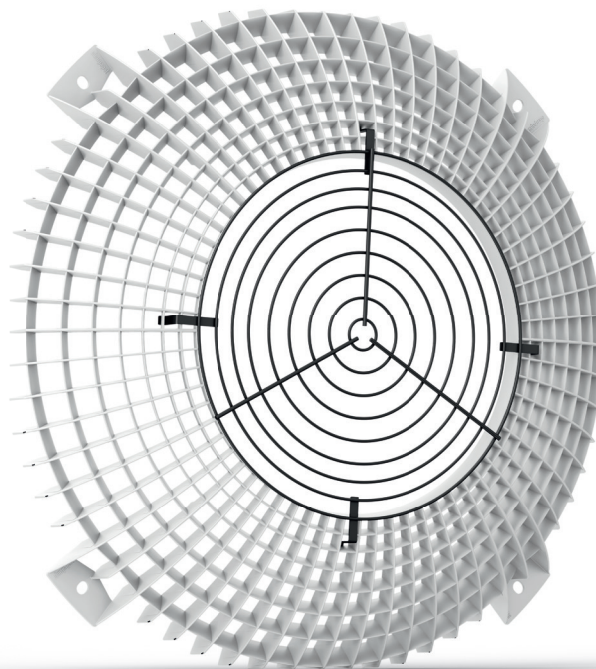

# Inlet rings

with / without measuring device



– Material: Plastic ABS

## Inlet rings with / without measuring device to determine the air flow for EC centrifugal fans - RadiPac - C

Part number without measuring device	Part number with one pressure tap	Fan Size	Dimensions / drawing
8217102502	8217104581	280	see Page 97
8217101930	8217102242	310	see Page 97
8217101928	8217102240	355	see Page 97
8217101929	8217102241	400	see Page 97
8217101922	8217102239	450	see Page 98
8217101923	8217102238	500	see Page 98
8217101924	8217102237	560	see Page 99
8217101925	8217102236	630	see Page 99

Subject to changes.

without  
measuring device:

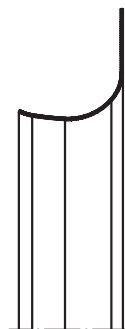

with one  
pressure tap:

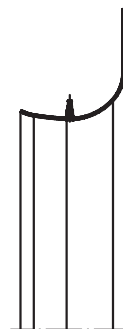



# Inlet rings

Dimensioned drawings for Inlet rings with / without measuring device

Fan size 280:

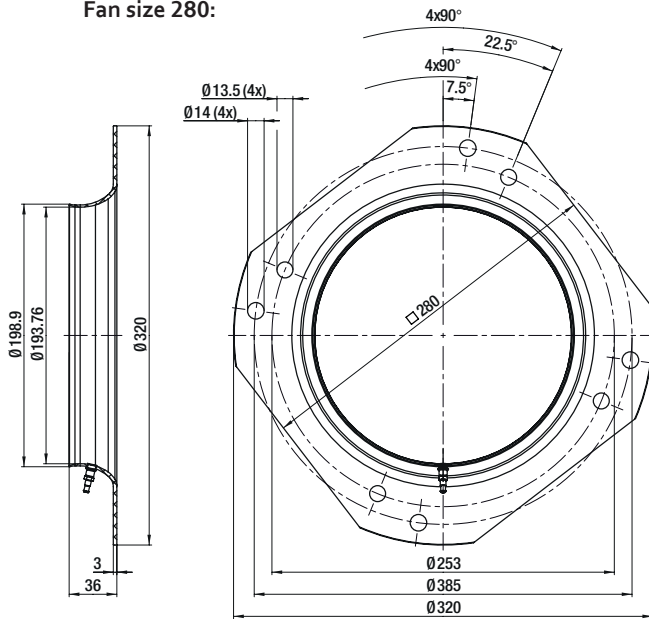

Fan size 310:

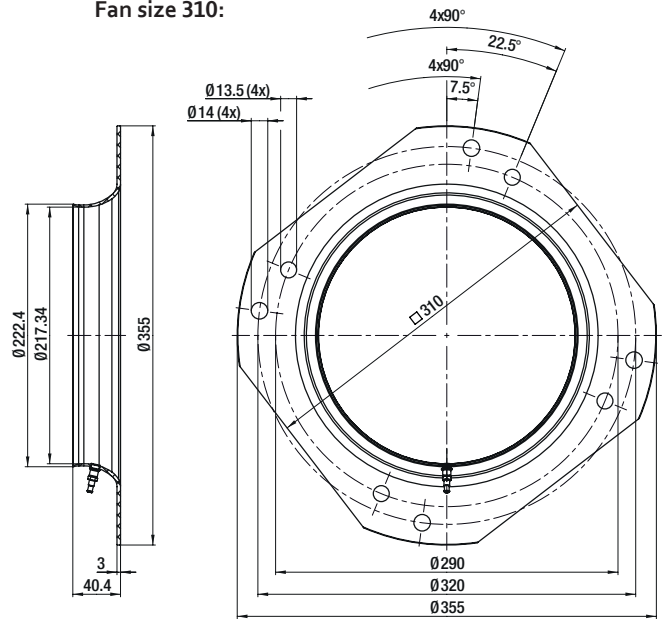

Fan size 355:

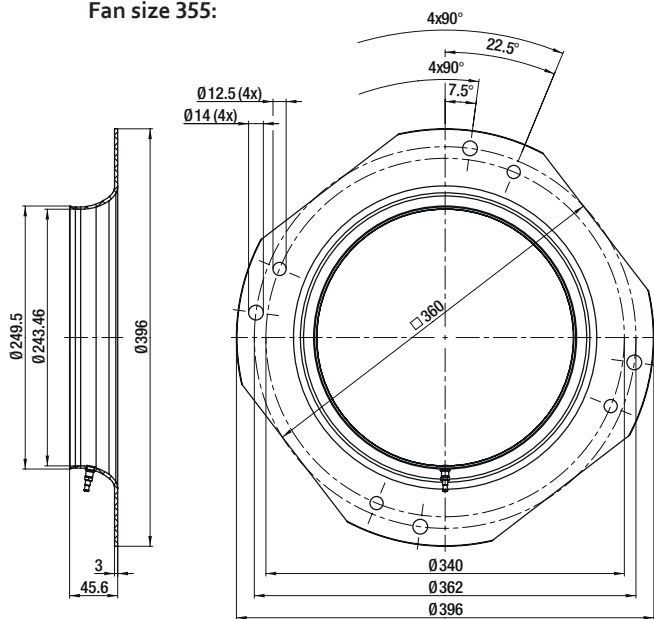

Fan size 400:

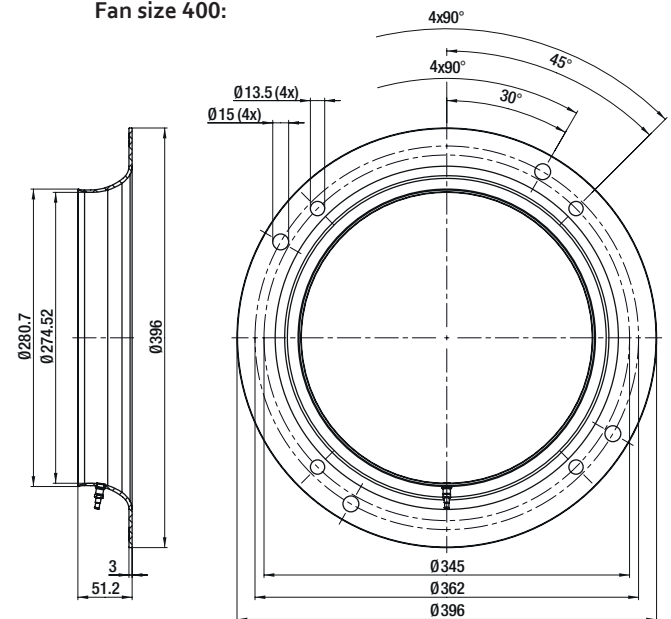

# Inlet rings

Dimensioned drawings for Inlet rings with / without measuring device

Fan size 450:

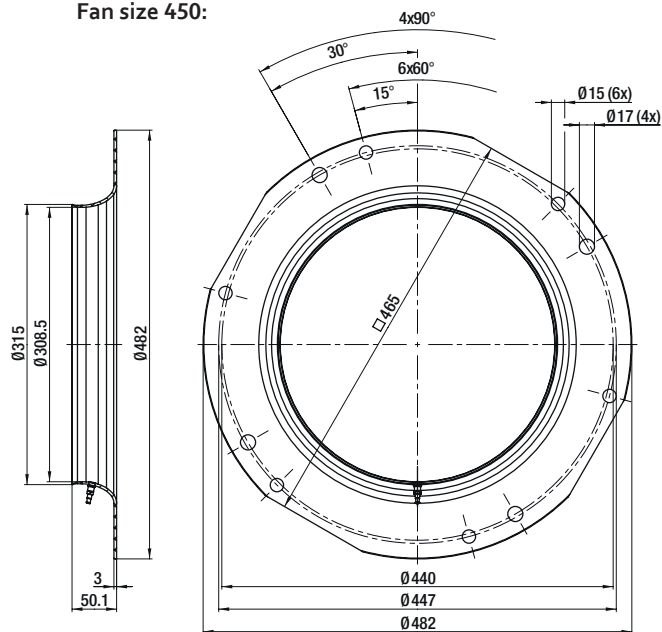

Fan size 500:

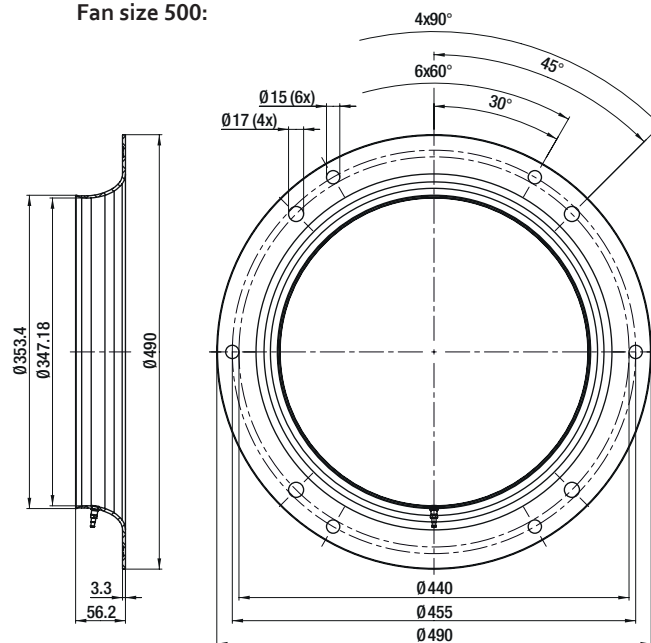

# Inlet rings

Dimensioned drawings for Inlet rings with / without measuring device

Fan size 560:

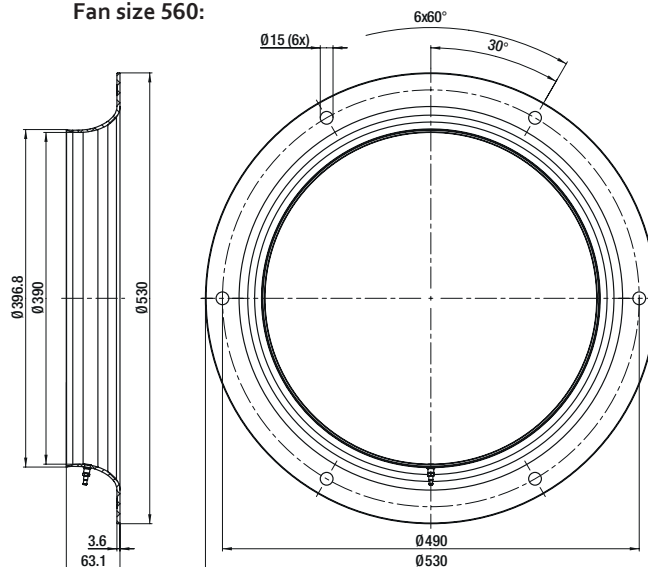

Fan size 630:

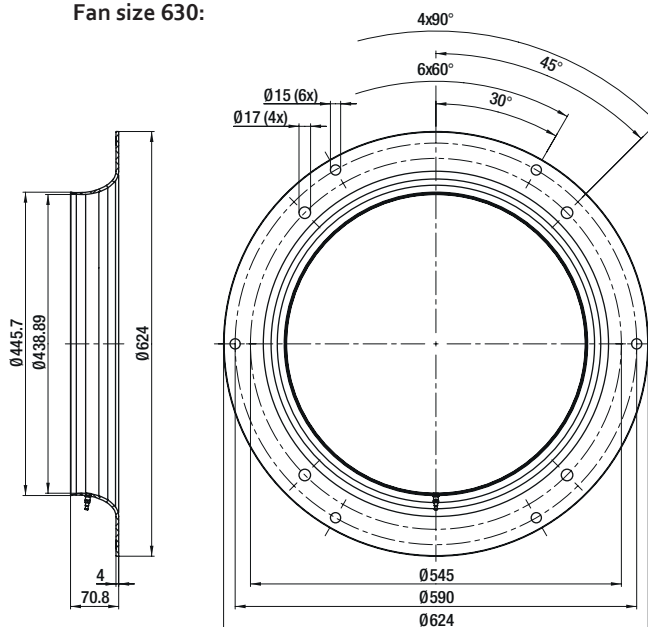

*ebm-papst*

# EC centrifugal fans & modules

## RadiPac - C Technology

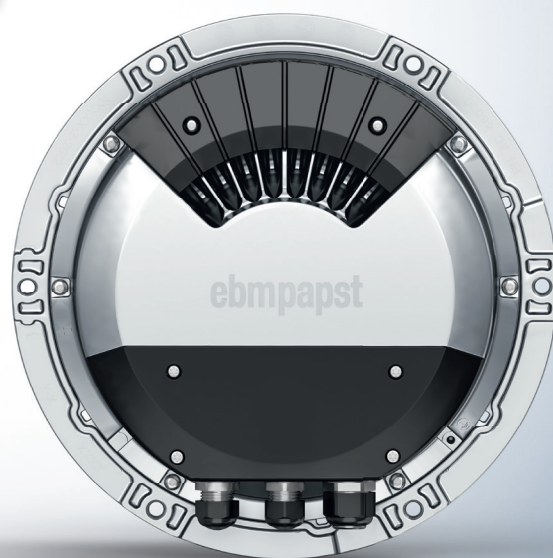

**ebmpapst**

engineering a better life

# Technology 280 - 630

	Page
Connection diagrams	102
Effects of installation space	108
Air flow measurement	109
Technical parameters & scope	110

# Connection diagrams

## Technical features:

- Operation and fault indicator with LED
- External 15-50 VDC input (parameterization)
- Alarm relay
- Integrated PI controller
- Configurable inputs/outputs (I/O)
- MODBUS V6.3
- Motor current limitation
- RS 485 MODBUS-RTU
- Soft start
- Voltage output 3,3-24 VDC, Pmax = 800 mW
- Control interface with SELV potential safely disconnected from supply
- Thermal overload protection for electronics/motor
- Undervoltage/phase failure detection
- Vibration sensor

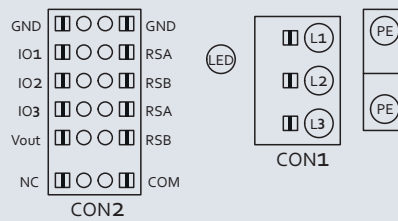

### Technical features:

- Output 10 VDC max. 10 mA
- Operation and fault indicator
- External 24 V input (parameterization)
- Alarm relay
- Integrated PI controller
- MODBUS V5.1
- Motor current limitation
- PFC, passive
- RS 485 MODBUS-RTU
- Soft start
- EEPROM write cycles: 100.000 maximum
- Control input 0-10 VDC / PWM
- Control interface with SELV potential safely disconnected from supply
- Thermal overload protection for electronics/motor
- Undervoltage/phase failure detection



# Connection diagrams

## Technical features:

- Operation and fault indicator with LED
- External 15-50 VDC input (parameterization)
- Alarm relay
- Integrated PI controller
- Configurable inputs/outputs (I/O)
- MODBUS V6.4
- Motor current limitation
- PFC, active
- RS 485 MODBUS-RTU
- Soft start
- Voltage output 3,3-24 VDC, Pmax = 800 mW
- Control interface with SELV potential safely disconnected from supply
- Thermal overload protection for electronics/motor
- Undervoltage/phase failure detection
- Vibration sensor

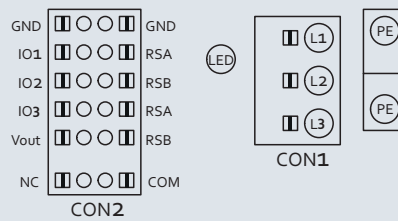



### Technical features:

- Output 10 VDC max. 10 mA
- Operation and fault indicator
- Alarm relay
- Integrated PI controller
- Power limiter
- Motor current limitation
- PFC, active
- RS485 MODBUS-RTU
- Soft start
- Control input 0-10 VDC / PWM
- Control interface with SELV potential safely disconnected from supply
- Thermal overload protection for electronics/motor
- Undervoltage/phase failure detection



# Connection diagrams

## Technical features:

- Output 10 VDC max. 10 mA
- Tach output
- Power limiter
- Motor current limitation
- Soft start
- Control input 0-10 VDC / PWM
- Control interface with SELV potential safely disconnected from supply
- Overvoltage detection
- Thermal overload protection for electronics/motor
- Line undervoltage detection

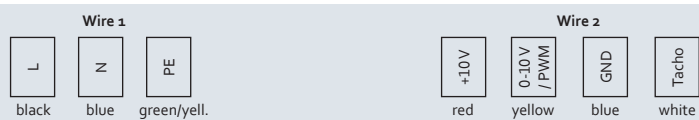

### Technical features:

- Output 10 VDC max. 1,1 mA
- Locked-rotor detection
- Tach output
- Speed control
- Power limiter
- Motor current limitation
- Soft start
- Control input 0-10 VDC / PWM
- Thermal overload protection for electronics/motor
- Overvoltage detection
- Control interface with SELV potential safely disconnected from supply
- Line undervoltage detection

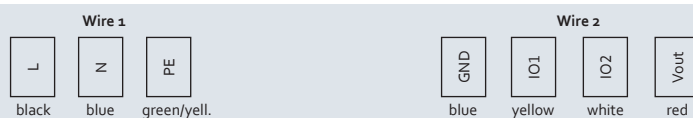

# Effects of installation space

for EC centrifugal fans

Effects of installation space: Installation in a square box may cause a reduction of the air performance.

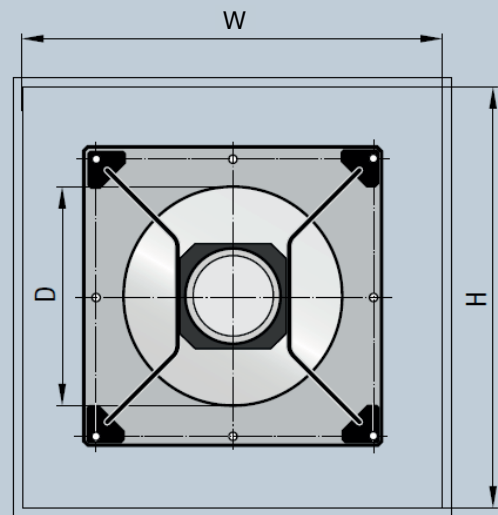
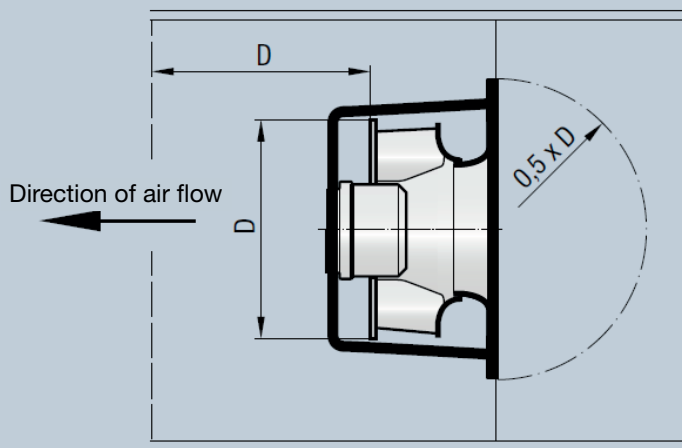

$d_h$  = hydraulic diameter

W = Width of the box

Formula:  $d_h = 2 \times W \times H / (W + H)$

H = Height of the box

D = Outside diameter of the fan impeller

Correction values  
for the air flow  
Fan size 310 - 630:

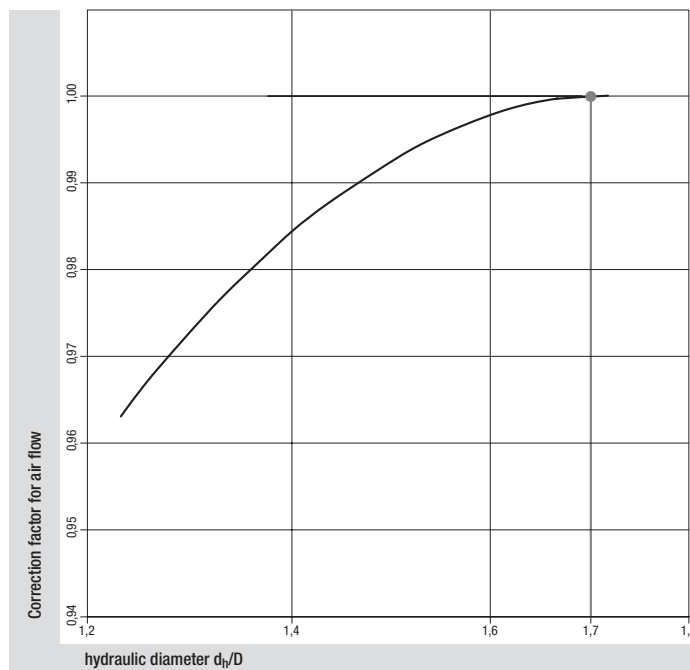

The correction values shown here were determined from an extensive series of measurements taken on our own internal chamber test rig. Here, square and rectangular outflow cross sections were considered. This is why the hydraulic diameter was used to determine the correction values.

The new RadiPac fans are known to be less vulnerable to tight installation situations. For square cross sections that are greater than 1.7 x the impeller diameter, no deduction has to be applied to the catalog curves.

# Airflow determination

## for EC centrifugal fans

### Airflow determination:

The differential pressure method compares the static pressure upstream of the inlet ring with the static pressure in the inlet ring.

The airflow can be calculated from the differential pressure (between the static pressures) according to the following equation:

$$qV = k \cdot \sqrt{\Delta p} \quad qV \text{ in [m}^3/\text{h] and } \Delta p \text{ in [Pa]}$$

If the airflow is to be regulated to remain constant, the inlet pressure must be kept constant:

$$\Delta p = qV^2 : k^2$$

k takes the specific properties of the inlet ring into account.

The pressure is tapped at 1 point on the circumference of the inlet ring.

The connection on the customer side is made directly at the pressure tap via a (pneumatic) hose with an inner diameter of 6 mm.

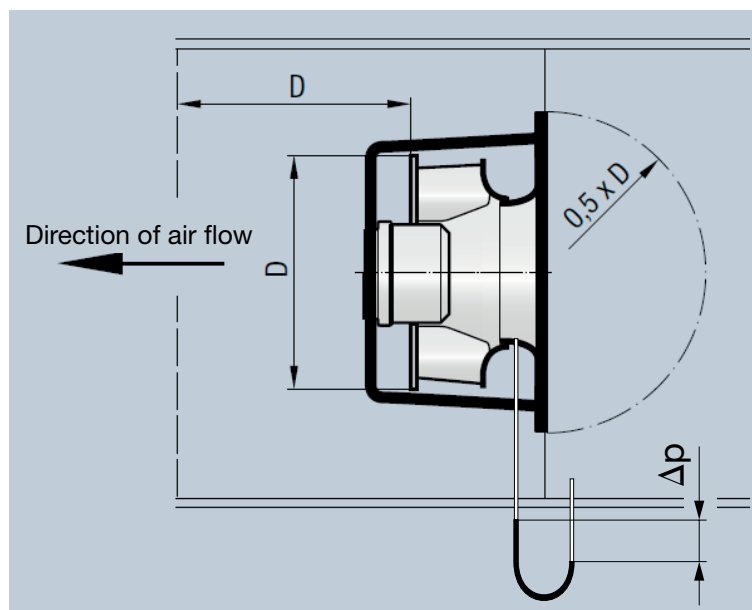

### k-factors: (for RadiPac - C inlet rings)

Fan size	k-factor
280	98
310	115
355	145
400	190
450	232
500	290
560	381
630	463

# Technical parameters & scope

## High standards for all ebm-papst products

Here at ebm-papst, we constantly strive to further improve our products in order to be able to offer you the best possible product for your application. Careful monitoring of the market ensures that technical innovations are reflected in the improvements of our products. Based on the technical parameters listed below and the ambience you want our product to operate in, we here at ebm-papst can always work out the best solution for your specific application.

### General performance parameters

Any deviations from the technical data and parameters described here are listed on the product-specific data sheet.

### Degree of protection

The type of protection is specified in the product-specific data sheets.

### Insulation class

The insulation class is specified in the product-specific data sheets.

### Installation position

The mounting position is specified in the product-specific data sheets.

### Condensate discharge holes

Information on the condensate discharge holes is provided in the product-specific data sheets.

### Mode of operation

The mode of operation is specified in the product-specific data sheets.

### Protection class

The protection class is specified in the product-specific data sheets.

### Tightening torques for fan assembly

Please consult your ebm-papst contact for questions about which tightening torque to use.

### Service life

The service life of ebm-papst products depends on two main factors:

- The service life of the insulation system
- The service life of the bearing system

The service life of the insulation system is essentially governed by the voltage level, the temperature and the ambient conditions such as humidity and condensation.

The service life of the bearing system is primarily governed by the thermal load on the bearings. For the majority of our products we use maintenance-free ball bearings which can be fitted in any installation position.

As a rough guide (depending on the general conditions), the ball bearings have a life expectancy L10 of approx. 40.000 hours of operation at an ambient temperature of 40 °C.

We will gladly provide you with a life expectancy calculation based on your specific usage conditions.

### Motor protection/thermal protection

Information on motor protection and thermal protection is provided in the product-specific data sheets.

The following protection methods are provided depending on the type of motor and area of application:

- Thermal overload protector, in-circuit or external
- PTC with electronic diagnostics
- Impedance protection
- Thermal overload protector with electronic diagnostics
- Current limitation via electronics

If use is made of an external thermal overload protector, a commercially available tripping unit must be connected by the customer for shut-off. Motor protection conforming to the applicable standard must be fitted for products not provided with a built-in thermal overload protector and not protected against improper use.

### Mechanical strain/performance parameters

All ebm-papst products are subjected to comprehensive testing in conformity with the normative specifications and also incorporating the extensive experience of ebm-papst.

### Vibration testing

Vibration testing is performed as follows:

- Vibration test in operation according to DIN IEC 68 Part 2-6
- Vibration test at standstill according to DIN IEC 68 Part 2-6

### Shock load

Shock load testing is performed as follows:

- Shock load according to DIN IEC 68 Part 2-27

### Balancing grade

Balancing grade testing is performed as follows:

- Residual imbalance according to DIN ISO 1940
- Standard balancing quality level G 6.3

Should your particular application require a higher level of balancing, please contact us and specify the details in your order.

### Chemical and physical strain/performance parameters

Please consult your ebm-papst contact for any questions regarding chemical and physical strain.

### Areas of use, industries & applications

Our products are used in a variety of industries and for numerous applications:

Ventilation, air conditioning and refrigeration technology, clean room technology, automotive and railway engineering, medical and laboratory technology, electronics, computer and office systems, telecommunications, household appliances, heating systems, machinery and installations, drive engineering. Our products are not intended for use in the aerospace or military industries!

### Legal and normative specifications

The products described in this catalog are developed and manufactured in accordance with the standards applying to the particular product and, if known, in accordance with the conditions of the particular area of application.

### Standards

Information on standards is provided in the product-specific data sheets.

### EMC

Information on EMC standards is provided in the product-specific data sheets. Compliance with EMC standards has to be assessed on the final product, as EMC properties may change under different installation conditions.

### Touch current

Information on touch current is provided in the product-specific data sheets. Measurement is performed according to IEC 60990.

### Approvals

Please contact us if you require a specific type of approval (VDE, UL, GOST, CCC, CSA, etc.) for your ebm-papst product. Most of our products can be supplied with the applicable approval. Information on existing approvals is provided in the product-specific data sheets.

### Air performance measurements

All air performance measurements are conducted on intake-side chamber test rigs conforming to the requirements of ISO 5801 and DIN 24163. The fans under test are attached to the measuring chamber with free air intake and exhaust (installation category A) and operated at nominal voltage, with alternating current also at nominal frequency, without any additional attachments such as a guard grill.

As required by the standards, the air performance curves shown are referenced to an air density of 1,15 kg/m<sup>3</sup>.

# Technical parameters & scope

## Acoustic

### Air and sound measurement conditions

Measurements on ebm-papst products are taken under the following conditions:

- Axial and diagonal fans in airflow direction "V" in full nozzle without guard grill
- Backward-curved centrifugal fans, free-running with inlet ring
- Forward-curved single and dual-inlet centrifugal fans with housing
- Backward-curved dual-inlet centrifugal fans with housing

### Sound measurements

All sound measurements are taken in anechoic rooms with reverberant floor. ebm-papst acoustic test chambers meet the requirements of accuracy class 1 as per DIN EN ISO 3745.

For sound measurement, the fans being tested are positioned in a reverberant wall and operated at nominal voltage, with alternating current also at nominal frequency, without any additional attachments such as a guard grill.

### Sound pressure and sound power level

All acoustic values are determined in accordance with ISO 13347, DIN 45635 and ISO 3744/3745 as per accuracy class 2 and given in A-rated form.

For measurement of the sound pressure level  $L_p$  the microphone is located on the intake side of the fan being tested, generally at a distance of 1 m on the fan axis.

For measurement of the sound power level  $L_w$  10 microphones are distributed over an enveloping surface on the intake side of the fan being tested (see graphic). The measured sound power level can be roughly calculated from the sound pressure level by adding 7 dB.

### Measurement set-up according to ISO 13347-3 and DIN 45635-38:

- 10 measuring points

$$d \geq D$$

$$h = 1,5d \dots 4,5d$$

$$\text{Measurement area } S = 6d^2 + 7d(h + 1,5d)$$

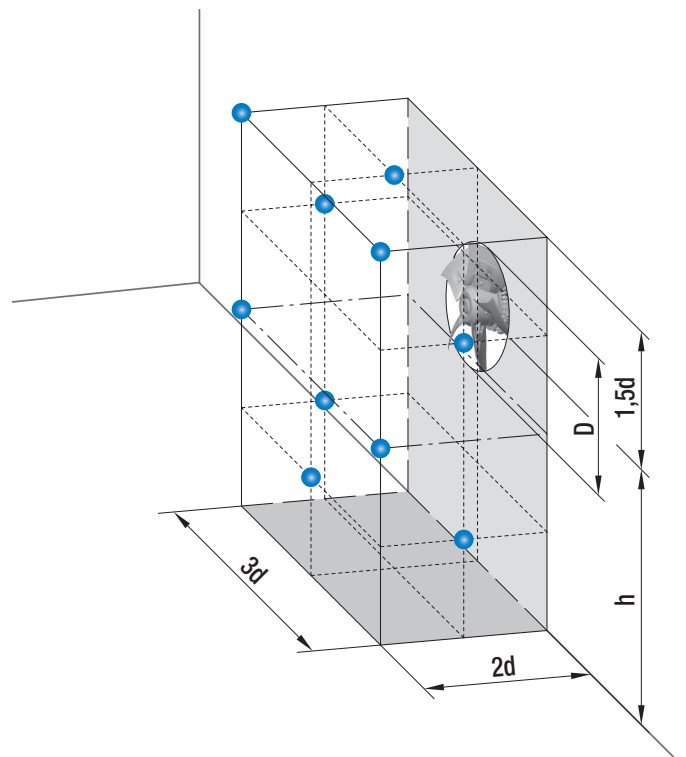



### Cumulative level of several sound sources with the same level

The addition of 2 sound sources with the same level produces a level increase of approx. 3 dB.

The noise characteristics of several identical fans can be predicted on the basis of the sound values specified in the data sheet. This is shown in the adjacent graph.

Example: There are 8 axial fans A3G800 on a condenser. According to the data sheet, the sound pressure level of one fan is 75 dB(A). The level increase determined from the graph is 9 dB. This means that a total level of 84 dB(A) is to be expected for the installation.

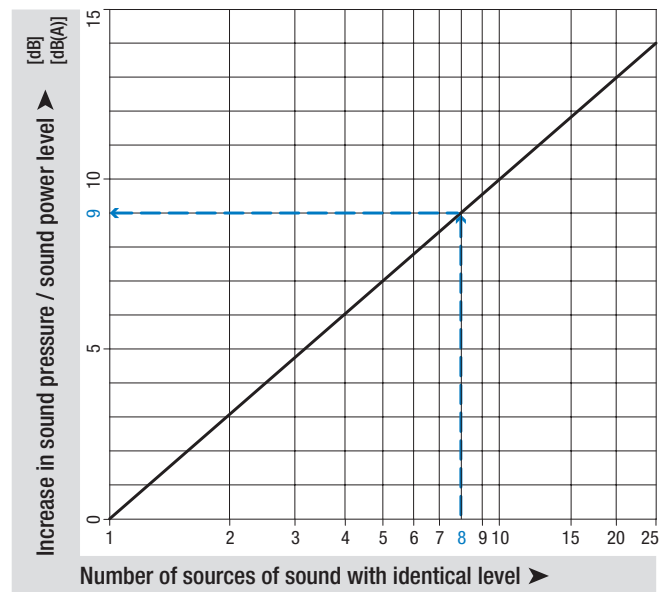

### Cumulative level of two sound sources with different levels

The noise characteristics of two different fans can be predicted on the basis of the sound values specified in the data sheet. This is shown in the adjacent graph.

Example: In a ventilation unit, there is one axial fan A3G800 with a sound pressure level of 75 dB(A) at the point of operation and one axial fan A3G710 with 71 dB(A). The difference in level is 4 dB. The level increase of approx. 1.5 dB can now be read off the graph. This means that a total level of 76.5 dB(A) is to be expected for the unit.

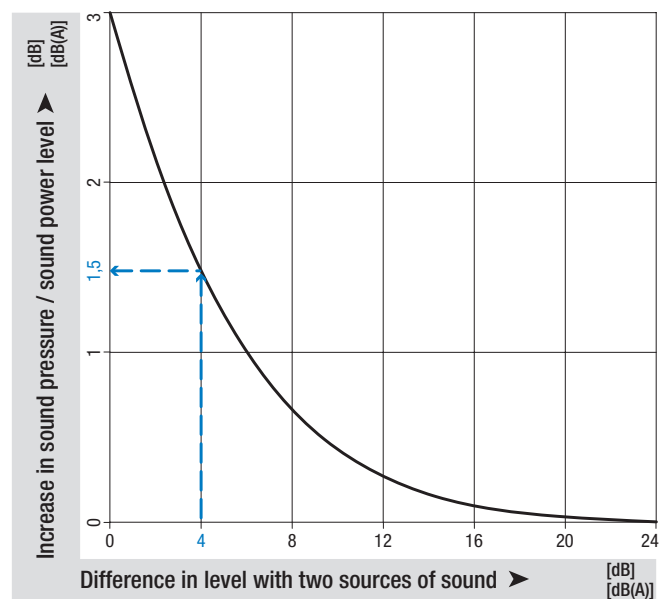

### Distance laws

The sound power level is not governed by the distance from the noise source. By contrast, the sound pressure level decreases with increasing distance from the sound source. The adjacent graph shows the decrease in level under far field conditions. Far field conditions apply if there is a considerable distance between the microphone and the fan in relation to the fan diameter and the wavelength under consideration. On account of the complexity of the topic, literature should be consulted for more detailed information on far fields. The level in the far field decreases by 6 dB each time the distance is doubled. Different relationships apply in the near field of the fan and the level may decrease to a far lesser extent. The following example only applies to far field conditions and may vary considerably as a result of installation effects:

For an axial fan A3G300, a sound pressure level of 65 dB(A) was measured at a distance of 1 m. From the adjacent graph, this would yield a reduction of 26 dB at a distance of 20 m, i.e. a sound pressure level of 39 dB(A).

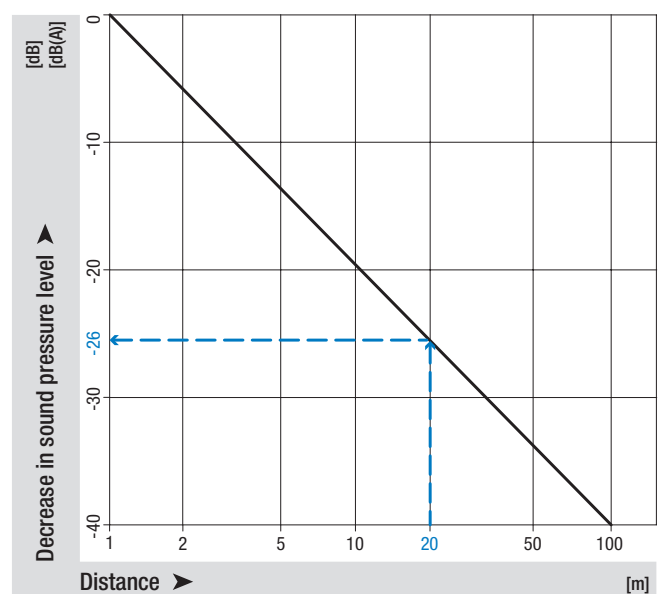

# Technical parameters & scope

## Acoustic

### Influence of Speed $n$ on the sound power level $L_w$ :

The sound power level for changes in speed can be approximately determined based on the adjoining diagram and the following formula:

$$L_{w_2} - L_{w_1} = 50 \text{ dB} \cdot \log (n_2 : n_1)$$

$L_{w_1}$  = Sound power level after speed change

$L_{w_2}$  = Sound power level before speed change

$n_1$  = Changed speed

$n_2$  = Initial speed

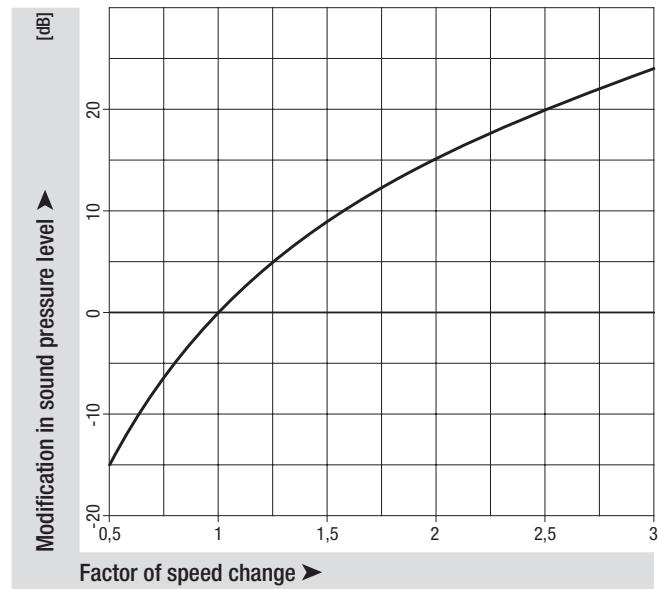

# Technical parameters & scope

## Aerodynamics fundamentals:

Further information can be found in our brochure "Technology - Basic principles"

### Centrifugal fan operating range:

Middle section of the air performance curve:

- Maximum efficiency
- Minimum noise

To the left and right of the middle section of the air performance curve:

- Reduced efficiency
- Increasing noise

The fan's optimal range of use is highlighted in green in the adjoining performance curve.

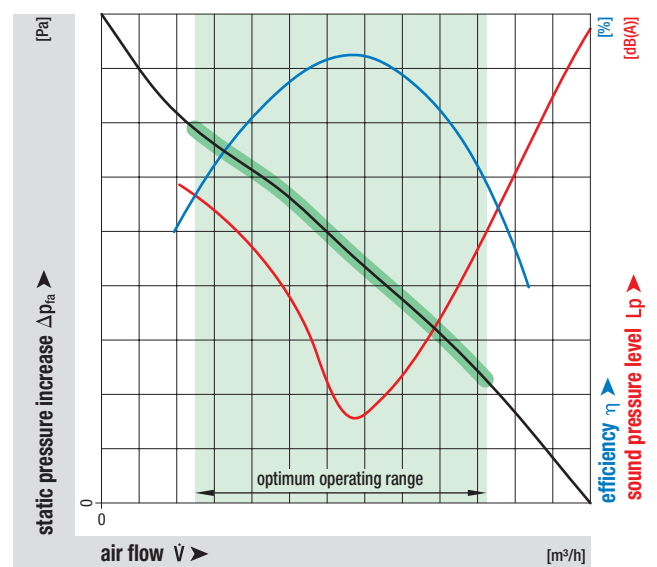

*EC centrifugal fans RadiPac - C*

# Contacts – Worldwide



*Always find the right contact person!*

**ebmpapst.com/contact**



**Germany**

**ebm-papst Mulfingen GmbH & Co. KG**

Bachmühle 2  
74673 Mulfingen  
GERMANY  
Phone +49 7938 81-0  
Fax +49 7938 81-110  
info1@de.ebmpapst.com

**ebm-papst St. Georgen GmbH & Co. KG**

Hermann-Papst-Straße 1  
78112 St. Georgen  
GERMANY  
Phone +49 7724 81-0  
Fax +49 7724 81-1309  
info2@de.ebmpapst.com

**ebm-papst Landshut GmbH**

Hofmark-Aich-Straße 25  
84030 Landshut  
GERMANY  
Phone +49 871 707-0  
Fax +49 871 707-465  
info3@de.ebmpapst.com

# Notes

# Notes

**ebmpapst**

engineering a better life

**ebm-papst**  
**Mulfingen GmbH & Co. KG**

Bachmühle 2  
74673 Mulfingen  
Germany  
Phone +49 7938 81-0  
Fax +49 7938 81-110  
info1@de.ebmpapst.com