

## RadiFit EC centrifugal fans.

Compact, efficient, easily upgraded.

# ebmpapst

The engineer's choice



# Fits, saves and makes sense!

*Our RadiFit range of centrifugal fans with scroll housing and backward-curved blades is the new system solution for many applications in industry and ventilation technology. Thanks to the highly efficient GreenTech EC motors, it offers high efficiency at high pressures. They are also extremely compact, robust and light. Best of all, RadiFit fans match the standard installation dimensions for fans. This makes installing and replacing them child's play.*



## Typical applications in air conditioning

### Example: Low profile air conditioning unit with RadiFit $\varnothing$ 250 mm

In air-conditioned buildings, the warm air is used to adjust the temperature of the incoming air. In this process, fans convey the air through the heat exchanger and then through the intake and exhaust air ducts. Due to strict energy conservation regulations, the fans must not only be compact and flexibly controllable, but also highly efficient. Just like our new RadiFit.



### Example: Central air handling unit with RadiFit $\varnothing$ 400 mm

Central air handling units use a variety of components such as filters, heat exchangers, humidifiers and de-humidifiers. The fans have to convey the air through all these components as well as through a branched system of ducts, whilst compensating for the high losses of pressure. At the same time, the system needs to use less space and allow many rooms to be ventilated according to demand. The solution comes in the form of our new EC centrifugal fans, which are flexible, robust and easy to install.



## Typical industrial implementation

### Example: Generator cooling with RadiFit $\varnothing$ 310 mm

A fan pushes the ambient air through narrow ducts on the generator in order to cool it. In this application, too, our centrifugal fans show off all their strengths. The integrated speed control allows the cooling to be adjusted to the load or heat generation of the generator at any time. The fan requires very little installation space, however, as it needs no separate control unit. It also requires no maintenance.

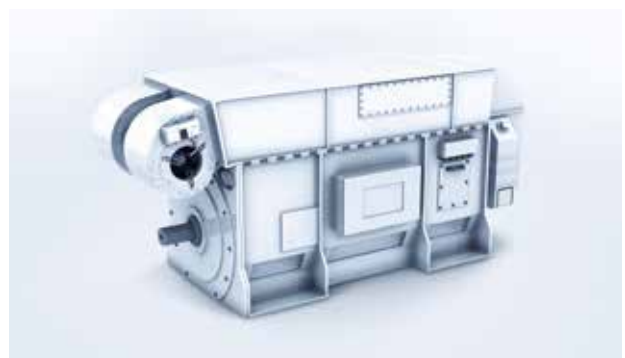

# Retrofit: replace with highly efficient technology.

Energy efficiency means lower operating costs. Our centrifugal fans with GreenTech EC technology are so much more advanced than normal fans, that even retrofitting existing units quickly pays for itself. Furthermore, our new range has a particularly long service life and requires no maintenance at all, which results in further cuts to operating and life cycle costs. Finally, we deliver the fans complete with housing and installed controlled electronics (VSD). This also reduces your installation costs to a minimum.

Comparing this to an obsolete belt drive and a flange-mounted motor makes the difference clear to see. Instead of connecting multiple components to each other at great effort and expense, RadiFit has everything integrated already, combined with minimal size and maximum energy efficiency.

## Centrifugal fans with belt drive

and external control electronics need a lot of space and have high maintenance costs related to wear-and-tear parts. Often, cheap and inefficient forward curved blowers are used here.

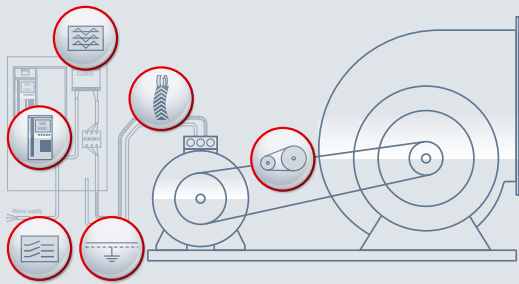

## RadiFit GreenTech EC centrifugal fan

In comparison, the RadiFit GreenTech EC centrifugal fan shows impressive efficiency and compactness. Thanks to the simple Plug & Play exchange system, running costs and maintenance work can be greatly reduced.

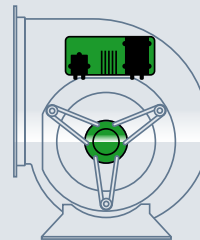

## Centrifugal fans with standard AC motor

are complex systems which require a lot of space for drive and control.

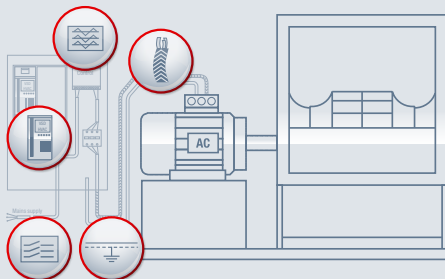

## RadiFit GreenTech EC centrifugal fan

The RadiFit impresses with its compactness and the efficient control technology of the GreenTech EC motor. With the innovative Plug & Play solution, operators can easily modernise their system and save costs over the long term.

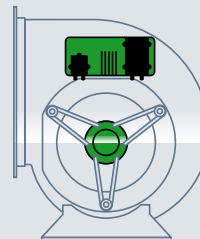

Fans are often assembled from various different components, mostly from different manufacturers. The user then has to ensure that these components fit together. This costs time and money, as well as being very stressful.

With the GreenTech EC solution from ebm-papst, you get a complete system, consisting of a motor, impeller and integrated variable speed drive. All from one source and ready configured. That means no extra components and simple commissioning.

# The system solution for every power range.

The performance measurements for all fans are conducted on cutting edge chamber test rigs as per ISO 5801. The entire fan unit, consisting of the motor, the control electronics, the impeller and the housing, is measured at different load levels. This provides us with reliable data, meaning that when you are choosing your fans,

you can count on these values being met. This rules out any nasty surprises when commissioning the fans. The measurement data form the basis for the design program available on request. Use this software to calculate expected operating costs or conduct a cost analysis for the life cycle.

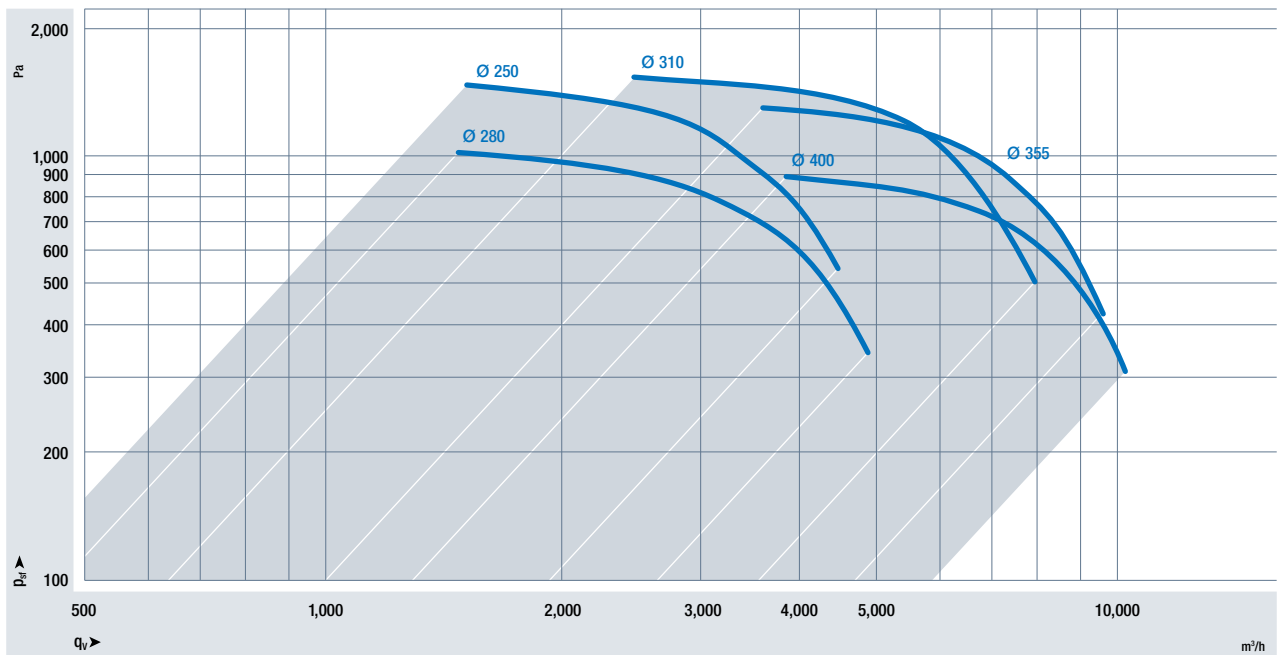

| Nominal data   |           | Nominal voltage range | Frequency | Speed/rpm <sup>(1)</sup> | Max. input power <sup>(1)</sup> | Max. current draw <sup>(1)</sup> | Perm. ambient temperature |
|----------------|-----------|-----------------------|-----------|--------------------------|---------------------------------|----------------------------------|---------------------------|
| Article number | Motor     | VAC                   | Hz        | min <sup>-1</sup>        | W                               | A                                | °C                        |
| D3G250-GG09-__ | M3G084-GF | 380-480               | 50/60     | 3,850                    | 1,810                           | 2.9                              | -25...+40                 |
| D3G280-GG10-__ | M3G084-GF | 380-480               | 50/60     | 2,900                    | 1,320                           | 2.1                              | -25...+40                 |
| D3G310-GG05-__ | M3G112-IA | 380-480               | 50/60     | 3,140                    | 3,180                           | 4.9                              | -25...+40                 |
| D3G355-GG03-__ | M3G112-IA | 380-480               | 50/60     | 2,600                    | 3,160                           | 4.9                              | -25...+40                 |
| D3G400-GG04-__ | M3G112-IA | 380-480               | 50/60     | 1,920                    | 2,380                           | 3.7                              | -25...+40                 |

(1) Nominal data in operating point with maximum load and 400 VAC

Superior in all areas.



#### Scroll housing

- + High static pressure**
  - High efficiency at high pressures
  - Lower pressure loss at full discharge
- + Fewer interferences**
  - Lower sensitivity to installation disturbances
  - Scroll housing tailored to the impeller
  - Inlet nozzle ideally matched to the impeller
- + Light and robust**
  - Impeller, motor, control electronics and housing in a single compact unit
  - Small construction volume at high flow rates
  - Galvanised sheet steel, corrosion resistant
- + Simple installation**
  - Housing with discharge and connection flange
  - Foot variants with easily movable feet or rectangular frame
  - Market-standard metric installation dimensions (simple 1:1 replacement)



#### High-performance impeller

- + High static efficiency**
  - Aerodynamically optimised blade duct
- + Lower noise emission**
  - Offset arranged blades
- + Low vibration**
  - Dynamic balancing of the impeller motor unit minimises the creation of structure-borne noise and reduces the bearing load
  - Proven vibration-insulated suspension
- + Robust design**
  - Suitable for constantly high circumferential speed
  - Corrosion-resistant aluminium
  - Robot-welded blades throughout





### GreenTech EC motor

- + Unrivalled compactness**
  - The impeller is mounted directly onto the motor rotor
- + High efficiency**
  - Low copper and iron losses
  - No slip loss due to synchronous running
  - No magnetic hysteresis losses in the rotor due to the use of permanent magnets (ferrite)
- + Economical operation**
  - Optimised commutation permits partial-load operation up to 1:10 while still maintaining high efficiency
- + Low noise emissions**
  - Commutation and stator design ensure low-noise magnetisation of the field system
  - High, acoustically imperceptible pulse frequency
- + Long service life**
  - Maintenance-free bearings
  - Brushless commutation
- + Safe operation**
  - Insulated bearing system to avoid bearing currents



### Electronics with connection section

- + Versatile**
  - Continuously controllable speed
  - Control signal 0–10 V DC and MODBUS
  - Flexible cable exit/moveable connection area
- + Universally applicable**
  - Different voltage variants for global use
  - Suitable for 50 and 60 Hz networks
- + Safe operation**
  - Integrated blocking and overheating protection
  - Environment-resistant cable glands
- + Simple commissioning**
  - Central terminal area for power connection, alarm relay and control and communication
  - Secure separation between terminal areas and electronics
  - High-quality connection terminals
  - No programming required during commissioning



# RadiFit for retrofit.

Two dimension systems have become established in recent years for housing fans. Imperial measurements in inches and metric measurements in line with DIN 323, norm series R20. The RadiFit fan housing sizes use metric dimensions and are therefore also suitable for 1:1 replacement in existing systems. Simple, fast, efficient.

## RadiFit with mounting bracket (90°) and flange

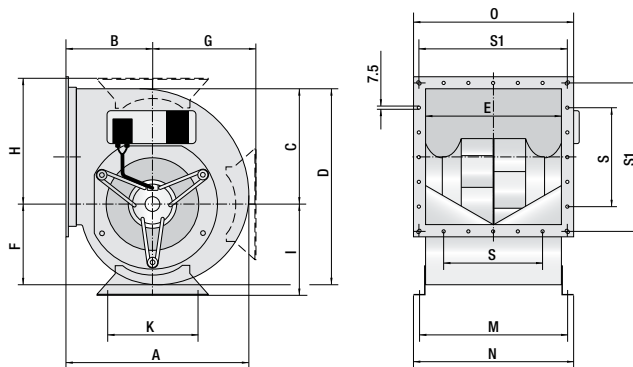

Dimensions in mm.

| Article number | A   | B   | C   | D   | E   | G   | H   | I   | K   | M   | N   | O   | S      | S1  |
|----------------|-----|-----|-----|-----|-----|-----|-----|-----|-----|-----|-----|-----|--------|-----|
| D3G250-GG09-01 | 432 | 205 | 269 | 455 | 322 | 258 | 306 | 220 | 224 | 348 | 377 | 379 | 3 x 90 | 352 |
| D3G280-GG10-01 | 474 | 225 | 302 | 512 | 361 | 270 | 331 | 243 | 280 | 392 | 416 | 418 | 3 x 90 | 391 |
| D3G310-GG05-01 | 529 | 246 | 341 | 573 | 404 | 305 | 370 | 258 | 280 | 436 | 466 | 462 | 4 x 90 | 434 |
| D3G355-GG03-01 | 592 | 271 | 383 | 648 | 453 | 340 | 409 | 287 | 355 | 494 | 515 | 511 | 4 x 90 | 483 |
| D3G400-GG04-01 | 649 | 300 | 432 | 727 | 507 | 380 | 458 | 318 | 355 | 549 | 569 | 565 | 5 x 90 | 537 |

The RadiFit with mounting bracket is supplied with a connection flange on the outlet side and fastening feet mounted in the 90° housing position. The feet can be easily moved according to the housing positions at 0° and 270°. At 180°, the flange is preferred for mounting.

## RadiFit with frame and flange

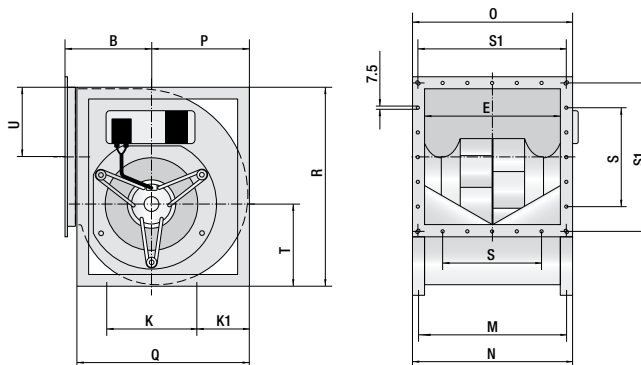

Dimensions in mm.

| Article number | A   | B   | C   | D   | E   | G   | H   | I   | K   | K1  | M   | N   | O   | P   | Q   | R   | S      | T   | U   |
|----------------|-----|-----|-----|-----|-----|-----|-----|-----|-----|-----|-----|-----|-----|-----|-----|-----|--------|-----|-----|
| D3G310-GG05-04 | 529 | 246 | 341 | 573 | 404 | 305 | 370 | 258 | 280 | 105 | 436 | 466 | 462 | 283 | 490 | 578 | 4 x 90 | 235 | 203 |
| D3G355-GG03-04 | 592 | 271 | 383 | 648 | 453 | 340 | 400 | 287 | 355 | 95  | 494 | 515 | 511 | 319 | 544 | 656 | 4 x 90 | 267 | 227 |
| D3G400-GG04-04 | 649 | 300 | 432 | 727 | 507 | 380 | 458 | 318 | 355 | 129 | 549 | 570 | 565 | 361 | 612 | 736 | 5 x 90 | 300 | 254 |

The RadiFit is also delivered with mounting frame and discharge side connection flange for sizes 310 and above.

**ebm-papst**  
**Mulfingen GmbH & Co. KG**

Bachmühle 2  
74673 Mulfingen  
Germany  
Phone +49 7938 81-0  
Fax +49 7938 81-110  
[info1@de.ebmpapst.com](mailto:info1@de.ebmpapst.com)

**ebmpapst**

The engineer's choice