

**ebmpapst**

engineering a better life

# Product overview of *motors and drive systems.*

Drive solutions | Industrial drive technology

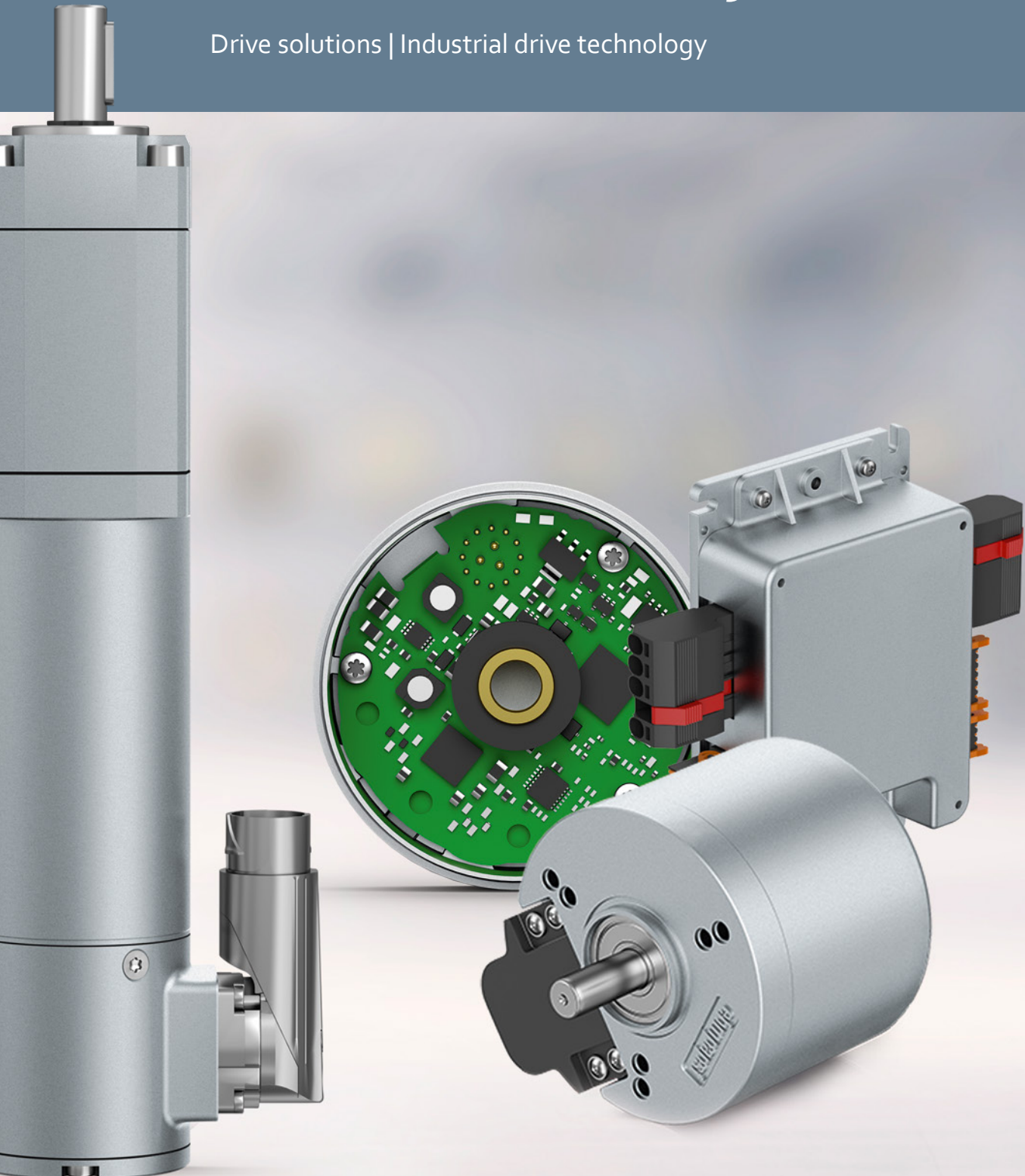

Augmented Reality  
Content Inside

# Three core competencies, *unique synergy effects.*

An excellent system solution requires three things:

## Gearbox engineering:

Three different gear technologies are available for combination with ebm-papst's innovative motor technology: Planetary, crown and spur gears. They are perfectly suited to the motor-specific performance parameters and shape factors, e.g. to speed and torque,

as well as to individual dimensions. When the components work together, a drive solution is created that satisfies all the requirements of the application in question.

*From Page 14*

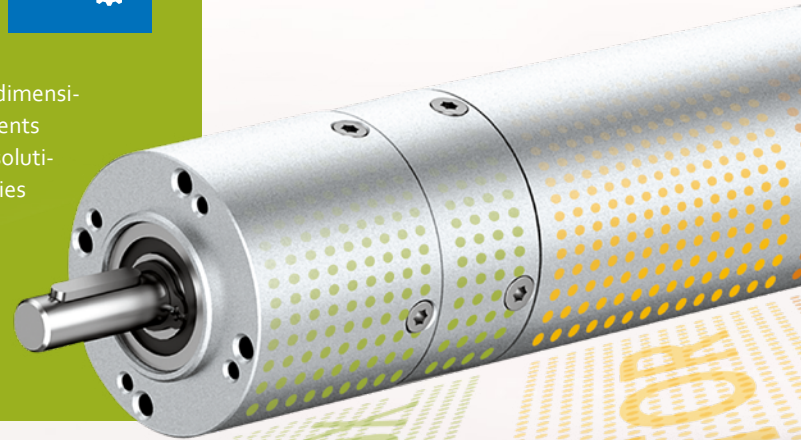

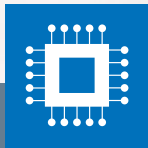

### Electronics:

Our electronics modules can also be combined flexibly with the ECI, VD/VDC and BCI series motors. Depending on the application-specific requirement, our customers can take advantage of a wide range of control functions. Speed, torque

and position-controlled operation of the motor can be implemented as required. The motor can be controlled via digital or analog inputs/outputs and via standardized BUS interfaces.

*From Page 22*



### Innovative motor technology:

There are 3 different motor concepts available here. The internal rotor motors in the ECI series offer output powers of up to 750 W. These brushless DC motors are at the heart of the drive solution in a modular system. The external rotor motors in the VD/VDC series are the method of choice if high requirements are placed on synchro-

nous operation and compact dimensions. The range of motors is rounded off with brushed motors in the BC series. These provide an economical alternative if the operating behavior of a classic, mechanically commutated DC motor is good enough.

*From Page 8*

# You have everything in hand: *with our three digital helpers.*

## 1. The ebm-papst online portal for drive technology

A drive solution perfectly geared to your requirements – without excessive development costs? A real option thanks to the modular system from ebm-papst! And that's not all: You can even put your drive unit together yourself – simply and with just a few clicks online: in our IDT configurator.

There you can choose between various motors, gearboxes and electronics, on through to brakes and sensors. All the necessary information is available for every component, including specifications, characteristic curves and 3D models, etc. So you can assemble exactly the drive solution you want quickly and conveniently – and, as a special feature, study it from all sides in a 360° view.

### The best part:

You can start with your configuration right away – without the need for login and of course free of charge.

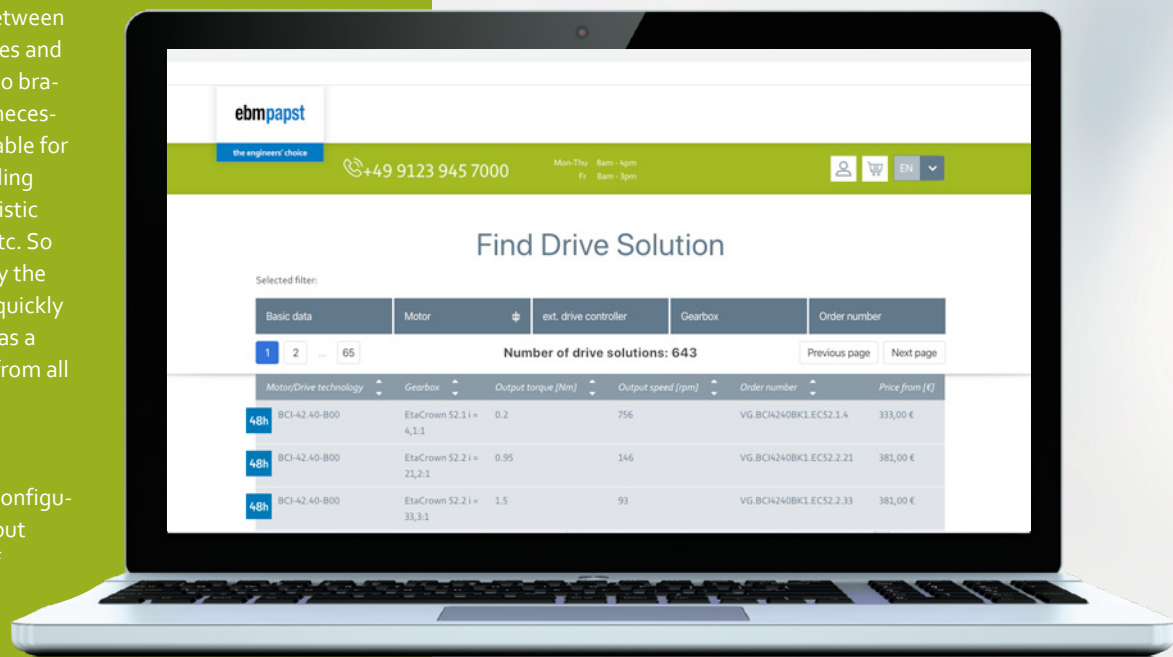

To visit the ebm-papst online portal, go to:  
[idt-config.ebmpapst.com](http://idt-config.ebmpapst.com)



## 2. The ebm-papst commissioning and service tool driveSTUDIO

Individual adaptation to the requirements of different applications is even easier and, above all, intuitive with the free driveSTUDIO software. Three different operating levels ensure that experienced application engineers and users with little knowledge of programming get results quickly.

For example, values for speed and torque can be output in the demo level. On the parameterization level, function diagrams assist users with inputs such as control loops, reference travels and the adjustment of acceleration and the braking ramp.

And particularly experienced users can freely program test runs of any travel sequences on the scripting level

### Your advantage:

driveSTUDIO runs on all PCs equipped with the Windows 7 or more recent operating system. It is available for free download in German and English:

[ebmpapst.com/drivestudio](http://ebmpapst.com/drivestudio)

## 3. The ebm-papst Xplore app

Download the digital world of ebm-papst onto your smartphone or tablet. Our ebm-papst Xplore app combines compact information with fascinating applications. It provides a whole new outlook on our products and technical components:

- AR content and interactive additional information for product brochures
- Selected product brochures as PDF downloads
- Virtual experience when visiting trade shows

### Good to know:

The app is constructed like a huge building kit. You can decide for yourself which modules you want to install or quite simply delete them again. Why not just try it out – simply download from the App Store or Play Store.

*Bring this brochure to life – with the ebm-papst “Xplore” app and augmented reality.*



### 1. Activate the module

Go into the ebm-papst Xplore app and select the “Product overview drive solutions” module.

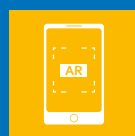

### 2. Scan the images

Aim the camera at the images marked with this icon, and away you go.



# Overview of our catalogues:



Motor concept BLDC internal rotor  
with appropriate modular system  
More on page 8



Motor concept BLDC external rotor  
with appropriate modular system  
More on page 10



Motor concept brushed internal rotor  
with appropriate modular system  
More on page 12



Scan the page and begin your  
virtual experience.  
Xplore App > Brochure module  
"Product overview drive solutions"

# Brushless internal rotor servomotors *ECl series*.

The outstanding features of the ECl series of electronically commutated internal rotor motors are their high power density and dynamic characteristics. They are ideal for robotics and numerous other appli-

cations. In the power range from 30 to 750 W, they are ready to move big things. In combination with planetary and crown gearheads, they exploit their full potential.

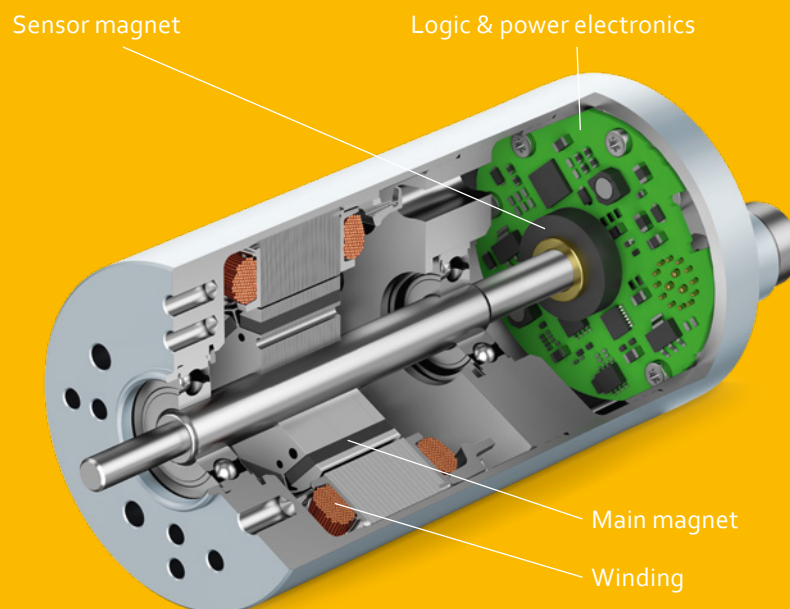

## Facts and Figures

- 3-phase, electronically commutated internal rotor motor with high-performance magnet
- Power range 30 to 750 W
- High power density with extremely compact dimensions
- High overload capacity
- Long service life
- Extremely smooth operation
- Rotor position detection by Hall sensors
- Customer-specific winding designs
- Winding insulation in accordance with insulation class E
- Degree of protection up to IP 54, in accordance with EN 60 034-5
- Various motor types can be combined with
- planetary and crown gearheads
- Integrated control electronics optional
- Encoder and brake attachment optional

## Approvals

- Support in the approval of products for various economic areas and markets
- We would be pleased to be your expert partner
- Possible approvals include CE, CCC, UL, CSA, EAC
- Additional approvals on request





Brushless internal rotor motors ECI		ECI-42.20-K1	ECI-42.40-K1	ECI-63.20-K1	ECI-63.40-K1	ECI-63.60-K1	ECI-63.20-K3/4/5	ECI-63.40-K3/4/5	ECI-63.60-K3/4/5	ECI-80.20-K1	ECI-80.40-K1	ECI-80.60-K1
		24	24	24	24	24	24	24	24	24	24	24
U <sub>N</sub>	V DC	48	48	48	48	48	48	48	48	48	48	48
M <sub>N</sub>	mNm	110	220	360	670	880	425	600	850	700	1 200	1 800
P	W	46	92	150	280	370	178	251	356	293	503	754
n <sub>N</sub>	rpm	4 000	4 000	4 000	4 000	4 000	4 000	4 000	4 000	4 000	4 000	4 000
l	mm	104	124	120	140	160	112	132	152	123.5	143.5	163.5
d	mm	42	42	63	63	63	63	63	63	80	80	80
Control electronics (integrated)												
K1 (Hall sensors)		•	•	•	•	•				•	•	•
K3 (speed)							•	•	•			
K4 (position)							•	•	•			
K5 (CANopen)							•	•	•			
K5E (EtherCAT)							•	•	•			
Control electronics (external)												
VTD-XX.XX-K3 (speed)		•	•	•	•	•						
VTD-XX.XX-K4S (position)		•	•	•	•	•				•	•	•
VTD-60.13-K5SB (CANopen)		•	•	•	•	•						
VTD-60.35-K5SB (CANopen)				•	•	•				•	•	•
VTD-60.10-K5E-S (EtherCAT)		•	•	•	•	•				•	•	•
VTD-60.35-K5E-S (EtherCAT)				•	•	•				•	•	•
Transmission												
NoiselessPlus 42 (planetary gear)		•	•									
NoiselessPlus 63 (planetary gear)				•	•	•	•	•	•			
Performax <sup>®</sup> 42 (planetary gear)		•	•									
Performax <sup>®</sup> 63 (planetary gear)				•	•	•	•	•	•			
Optimax 42 (planetary gear)		•	•									
Optimax 63 (planetary gear)				•	•	•	•	•	•	•	•	•
Optimax <sup>®</sup> 80 (planetary gear)										•	•	•
PE040 (low-backlash planetary gear)		•	•									
PE060 (low-backlash planetary gear)				•	•	•	•	•	•			
PE080 (low-backlash planetary gear)										•	•	•
EtaCrown <sup>®</sup> 52 (crown gearhead)		•	•									
EtaCrown <sup>®</sup> 75 (crown gearhead)				•	•	•	•	•	•			
EtaCrown <sup>®</sup> Plus 42 (crown gearhead)		•	•									
EtaCrown <sup>®</sup> Plus 63 (crown gearhead)				•	•	•	•	•	•			
Brakes												
RFK (standby current, spring force)		•	•	•	•	•	•	•	•	•	•	•
Encoder systems												
Magnetic encoder systems		•	•	•	•	•				•	•	•
Magnetischer Inkrementalgeber IEM 38		•	•							•	•	•
Magnetischer Inkrementalgeber IEM 58				•	•	•						
Absolutwertgeber multiturm AEM 35		•	•	•	•	•						

Subject to change  
• Standard type

With our **preferred types**, we offer a selection of motors and gear motors that are ready for shipment within 48 hours. The preferred types can be purchased with a maximum order quantity of 20 products per order.

With **standard types**, we refer to a wide range of motors and gear motors that can be purchased via specified order numbers with standard delivery times.

Other products available for project requirements are described on **request**. These products are generally available but cannot yet be ordered using the material number created. We reserve the right to create the necessary order number after technical and commercial evaluation of the requirement.

# Brushless external rotor motors *VD/VDC series.*

Our electronically commutated external rotor motors in the VD/VDC series impress with their durability and excellent control properties. In combination with planetary, crown and spur gearheads, a wide range of innovative applications are available, e.g. in the field of industrial automation.

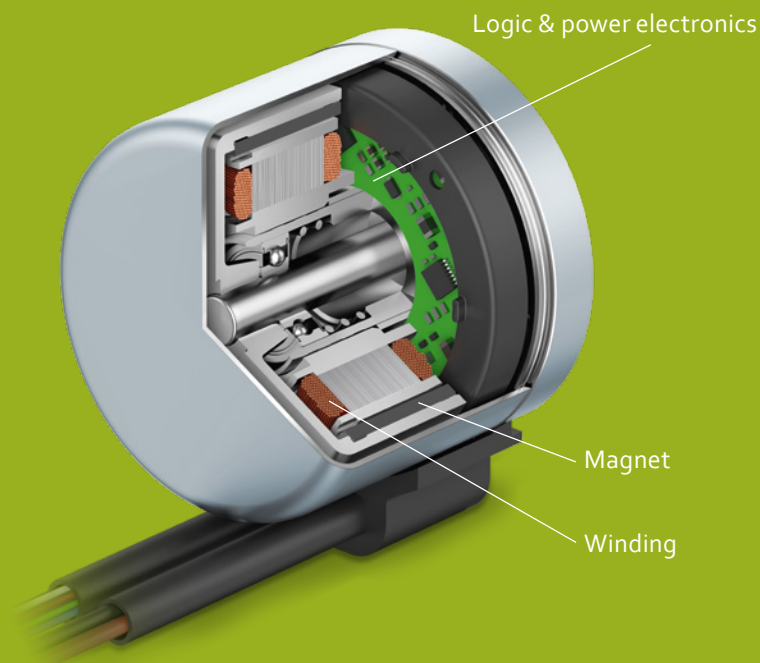

## Facts and Figures

- 3-phase, electronically commutated external rotor motor
- Power range 5 to 125 W
- High power density with extremely compact dimensions
- Excellent synchronization characteristics over the entire speed range
- High overload capacity
- Very high power density
- Steady speed/torque curve
- Extremely broad speed control range
- Robust housing and bearing system
- Degree of protection up to IP 54, in accordance with EN 60 034
- Different motor types can be combined with planetary, crown and spur gears

## Approvals

- Support in the approval of products for various economic areas and markets
- We would be pleased to be your expert partner
- Possible approvals include CE, CCC, UL, CSA, EAC
- Additional approvals on request



Brushless External rotor motors VD/VDC		VD-25.07	VD-35.06	VD-43.10	VD-54.14	VD-49.15	VDC-43.10	VDC-54.14	VDC-49.15	VDC-49.15	VDC-49.15
U <sub>N</sub>	V DC	24	24	24	24	24	24	24	24	24	48
M <sub>N</sub>	mNm	8.00	20.0	54.0	150	235	45.0	130	150	235	300
P	W	5.00	8.00	21.0	57.0	110	19.0	47.6	63.0	100	125
n <sub>N</sub>	rpm	6 000	3 700	3 700	3 700	4 500	4 000	3 500	4 000	4 000	4 000
l	mm	23.6	29.3	40.8	43.3	52.0	40.0	42.0	52.0	52.0	52.0
d	mm	32.0	44.0	52.8	68.4	63.0	52.8	68.3	63.0	63.0	63.0
Control electronics (integrated)											
K1 (Hall sensors)		●	●	●	●	●					
K3 (speed)							●	●	●		
K4 (position)										●	●
Control electronics (external)											
VTD-XX.XX-K3		●	●	●	●	●					
VTD-XX.XX-K4S					●	●					
VTD-60.13-K5 SB				●	●	●					
Gearheads											
NoiselessPlus 63 (planetary gearheads)						●					
Performax® 63 (planetary gearheads)						●				●	●
Performax®Plus 63 (planetary gearheads)						●				●	●
EtaCrown® 75 (crown gearheads)						●				●	●
EtaCrown®Plus 63 (crown gearheads)						●				●	●
Compactline 90 (spur gearheads)					●			●			
Compactline 91 (spur gearheads)			●	●	●	●	●	●	●	●	●
Compactline 92 (spur gearheads)					●			●			
Flatline 85 (spur gearheads)					●	●		●	●	●	●

Subject to change  
 ● Standard type

With our **preferred types**, we offer a selection of motors and gear motors that are ready for shipment within 48 hours. The preferred types can be purchased with a maximum order quantity of 20 products per order.

With **standard types**, we refer to a wide range of motors and gear motors that can be purchased via specified order numbers with standard delivery times.

Other products available for project requirements are described **on request**. These products are generally available but cannot yet be ordered using the material number created. We reserve the right to create the necessary order number after technical and commercial evaluation of the requirement.

# Brushed internal rotor motors

## *BCI series.*

The mechanically commutated DC motors in the BCI series are available in three different sizes and many voltage variants. In combination with our planetary, crown and spur gearheads, there are a wide range of applications.

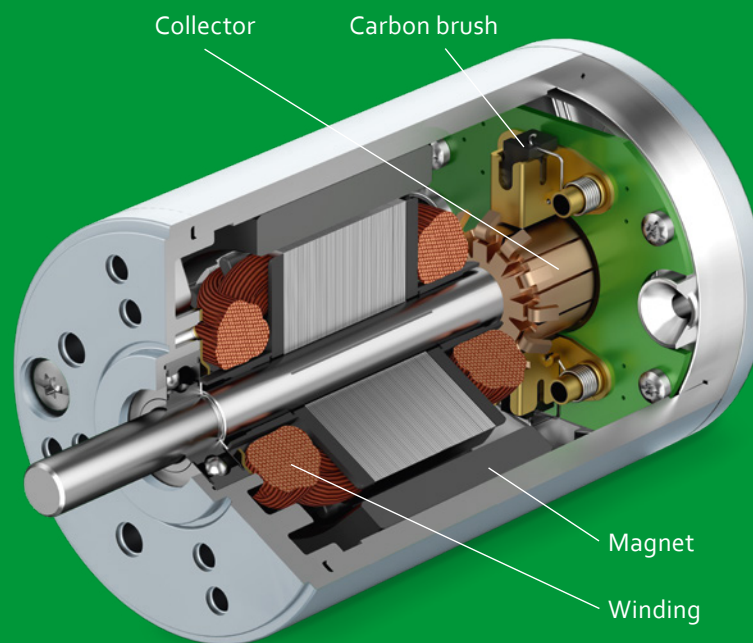

### Facts and Figures

- DC motor with permanent magnets
- Power range 13 to 93 W
- High power density with extremely compact dimensions
- High overload capacity
- High efficiency
- Mechanical commutation with multi-part collector
- Customer-specific winding design
- Winding insulation in accordance with insulation class B
- Degree of protection IP 40, optionally higher
- Encoder and brake attachment optional
- Different motor types can be combined with planetary, crown and spur gears

### Approvals

- Support in the approval of products for various economic areas and markets
- We would be pleased to be your expert partner
- Possible approvals include CE, CCC, UL, CSA, EAC or other test marks



Brushed internal rotor motors BCI		BCI-42.25	BCI-42.40	BCI-52.30	BCI-52.60	BCI-63.25	BCI-63.55
$U_N$	V DC	24	24	24	24	24	24
$M_N$	mNm	38.0	57.0	100	170	140	270
P	W	13.0	19.0	38.0	55.0	46.0	93.0
$n_N$	rpm	3 300	3 100	3600	3100	3150	3 300
l	mm	70.0	85.0	95.0	125	95.0	125
d	mm	42.0	42.0	52.0	52.0	63.0	63.0
<b>Gearbox</b>							
Performax® 42 (planetary gearbox)		●	●				
Performax® 52 (planetary gearbox)				●	●		
Performax® 63 (planetary gearbox)						●	●
EtaCrown® 52 (crown gearbox)		●	●				
EtaCrown® 75 (crown gearbox)						●	●
EtaCrown®Plus 42 (crown gearbox)		●	●				
EtaCrown®Plus 63 (crown gearbox)						●	●
Compactline 90 (spur gearbox)		●	●				
Compactline 91 (spur gearbox)						●	●
Compactline 92 (spur gearbox)						●	●
Flatline 78 (spur gearbox)		●					
Flatline 85 (spur gearbox)						●	●
<b>Brakes</b>							
BFK (spring force)		●	●	●	●	●	●
<b>Encoder systems</b>							
PMG 2-2/2-12 (magnetic)		●	●	●	●	●	●
HEDS 5500/512 (optical, incremental)		●	●	●	●	●	●

Subject to change  
 ● Standard type

With our **preferred types**, we offer a selection of motors and gear motors that are ready for shipment within 48 hours. The preferred types can be purchased with a maximum order quantity of 20 products per order.

With **standard types**, we refer to a wide range of motors and gear motors that can be purchased via specified order numbers with standard delivery times.

Other products available for project requirements are described **on request**. These products are generally available but cannot yet be ordered using the material number created. We reserve the right to create the necessary order number after technical and commercial evaluation of the requirement.

# Durable, unique, maximum power density *our gearbox systems.*

We offer three different gear technologies in the gearbox product section. These include **planetary**, **angular** or **crown gear** and **spur gears**, which are adapted individually to the customer's requirements according to the modular system principle. Ultimately, the application itself decides which of the technologies offered will provide the best results.

The output shafts of the ebm-papst gearboxes are generally made of hardened and ground case-hardened steel, meaning that they are particularly durable. Torque is transmitted via a keyway connection as standard. For projects we offer alternative shaft designs and geometries.

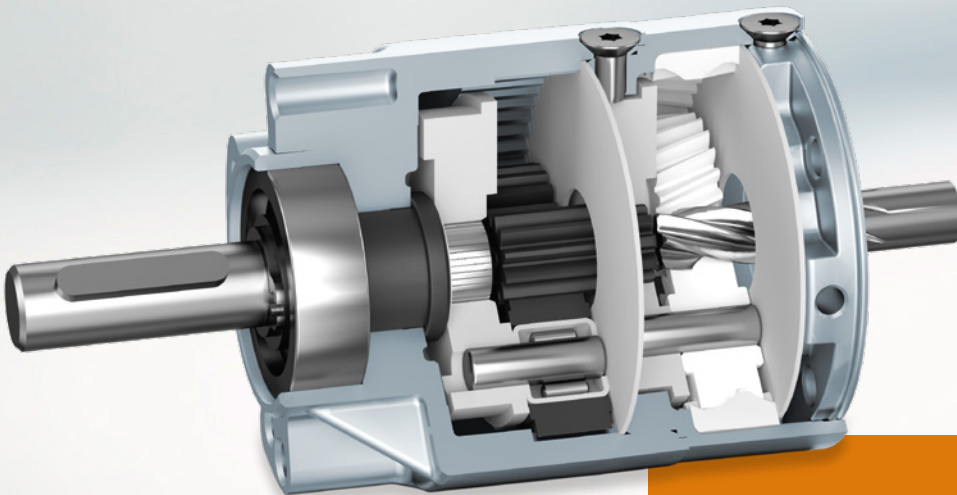

## Planetary Gears

Whenever high power densities are required, the extensive range of planetary gears from ebm-papst featuring three powerful series offers the ideal solution. All three strong product series impress with their extremely smooth operation, which is achieved thanks to extremely robust, sometimes straight and sometimes helical planetary gears made of high-strength plastic or steel.

*From Page 16*



## Crown gearbox

When it comes to crown gearheads, ebm-papst impresses with its innovative crown gearhead technology. It enables powerful, compact and highly efficient transmission solutions that can be produced extremely economically. The output shafts of all crown gearheads are made of ground, case-hardened steel and are therefore especially robust. Torque is transmitted via a keyway connection as standard. A special feature of the crown gearheads is the lack of self-locking.

*From Page 18*

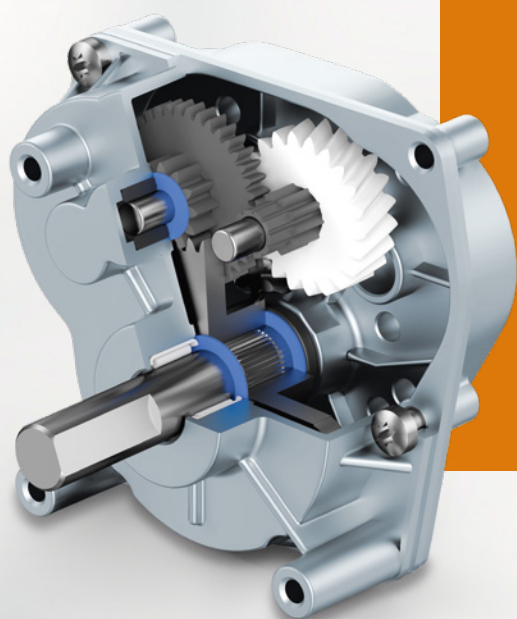

## Spur gears

Spur gears from ebm-papst are characterized by their space-saving design and extremely smooth operation. They are available in two powerful product series. Both the Flatline and Compactline transmissions impress by their outstanding value for money. Spur gears have a simple design, and can be combined with both VD/VDC and BCI motors.

*From Page 20*



# Planetary gears *for high power density.*

The comprehensive product range of **planetary gearboxes** is used when high power densities are required.

When it comes to achieving high efficiency with minimal noise, the **NoiselessPlus** is the impressive, obvious choice. Its exemplary smooth operation is achieved thanks to extremely sturdy, helical planetary wheels made of high-strength plastic.

**Performax®Plus** delivers smooth operation and high performance. Helical planetary wheels made of high-strength plastic ensure ex-

cellent smooth operation in the first stage.

The combination with a hardened ring gear in the output stage means that high outputs can be achieved.

**Optimax®** offers maximum robustness at the highest power density. Straight-toothed planetary wheels made of high-strength steel in the first and second gear stage allow high peak loads and also ensure that the transmission has a long life. If there are increased noise requirements, high-strength plastic planetary wheels can be implemented in the input stage as an option.



NoiselessPlus 42 und 63

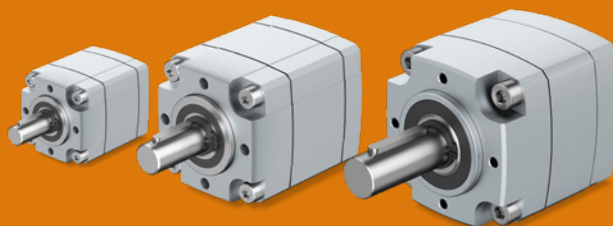

Optimax® 42, 63 und 80

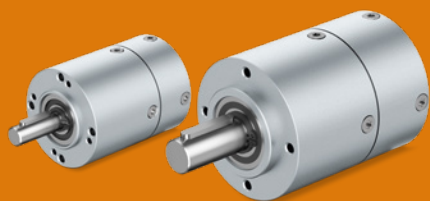

Performax®Plus 42 und 63

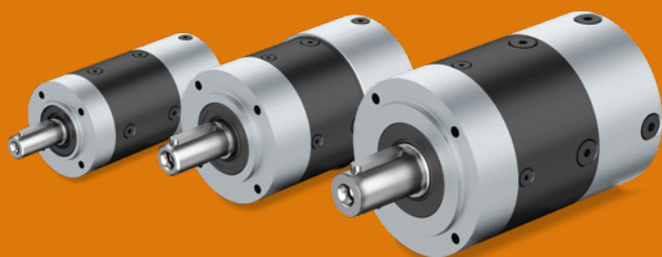

Low-backlash planetary gears PE040, PE060 and PE080

#### Overall advantages:

- Higher first and second stage reduction ratios
- Extremely smooth operation
- Outstanding performance
- Compact design
- No offset

#### Product series and their strengths:

- NoiselessPlus: unique smooth operation
- Performax®: extreme performance
- Optimax®: robust and durable



## Gearbox\*

			NoiselessPlus 42	NoiselessPlus 63	Performax <sup>®</sup> 42	Performax <sup>®</sup> 52	Performax <sup>®</sup> 63	Performax <sup>®</sup> Plus 42	Performax <sup>®</sup> Plus 63	Optimax 42	Optimax 63	Optimax 80
Number of stages												
1	Torque (M <sub>N</sub> )	Nm	up to 2.8	up to 10.5	up to 1.2	up to 3.0	up to 6.9	up to 2.6	up to 11.9	up to 16.0	up to 40.0	up to 70.0
	Reduction	r	4.30	4.30	3.20	3.20		3.20	3.20			
			6.00	6.00	5.0	5.0	5.00	5.00	5.00	3.00	3.00	3.00
			11.0	11.0	9.0	9.00	9.00	9.00	9.00	5.00	5.00	5.00
			21.0	21.0	17.0	17.0	17.0		17.0	9.00	9.00	9.00
Torque (M <sub>N</sub> )	Nm	up to 4.1	up to 9.4	up to 5.6	up to 14.9	up to 37.3	up to 12.1	up to 64	up to 27.0	up to 68.0	up to 115.0	
2	Reduction	r			21.3	21.3	21.25	21.3	21.3	9.00	9.00	9.00
			26.0		30.0	30.0	30.0	30.0	30.0			
					38.3	38.3	38.25		38.3	15.0	15.0	15.0
			47.6	26.0	54.0	54.0	54.0	54.0	54.0	25.0	25.0	25.0
			66.0	47.0	72.3	72.3	72.3		72.3			
			121	66.0	102	102	102		102	45.0	45.0	45.0
		231	121	204	204	204		204				

### Possible combinations with

#### ECI motors

ECI-42	●		●				●				
ECI-63		●				●		●		●	
ECI-80											●

#### VD/VDC motors

VD/VDC-43.10											
VD/VDC-54.14											
VD/VDC-49.15		●				●		●			

#### BCI motors

BCI-42			●								
BCI-52				●							
BCI-63						●					

Subject to change

\* The overview of the transmissions shows all possible reductions. The combination of the necessary reduction with the desired motor is described in the catalogue and on the homepage and is available on request.

# Angular gearboxes *with innovative crown gearhead technology.*

ebm-papst impresses with innovative **crown gearbox** technology in its family of angular gearboxes.

The **EtaCrown®** is a convincing offering with its wide reduction range and compact design. Space can always be saved during installation thanks to zero axle misalignment with a symmetrical structure.

High radial loads can also be incorporated via a double ball bearing on the output shaft.

The **EtaCrown®Plus** requires minimum assembly space while achieving maximum power. Thanks to a downstream planetary stage, it can achieve significantly higher torques compared to the EtaCrown® of the same size.



EtaCrown® 52 und 75



EtaCrown®Plus 42 und 63

**Overall advantages:**

- Outstanding efficiency
- Broad range of reduction ratios
- No self-locking
- Very high power density
- No offset

**Two strong product series:**

- EtaCrown®
- EtaCrown®Plus

## Gearbox\*

			EtaCrown® 52	EtaCrown® 75	EtaCrown® Plus 42	EtaCrown® Plus 63
<b>Number of stages</b>						
1	Torque ( $M_N$ )	Nm	up to 10	up to 10	up to 40	up to 40
	Reduction	r	4.10	4.10		
			6.0	6.70		
2	Torque ( $M_N$ )	Nm	up to 10	up to 10	up to 40	up to 40
	Reduction	r	21.2	20.3		
			33.3	33.3		
60.0			60.0			
3	Torque ( $M_N$ )	Nm	up to 10	up to 10	up to 40	up to 40
	Reduction	r	113	113	54.0	54.0
					84.8	84.8
				153	153	
				289	289	

### Possible combinations with

#### ECI motors

ECI-42	●			●		
ECI-63		●				●
ECI-80						

#### VD/VDC motors

VD/VDC-43.10						
VD/VDC-54.14						
VD/VDC-49.15			●			●

#### BCI motors

BCI-42	●			●		
BCI-52						
BCI-63			●			●

Subject to change

\* The overview of the transmissions shows all possible reductions. The combination of the necessary reduction with the desired motor is described in the catalogue and on the homepage and is available on request.

# Compact spur gears *with extremely smooth operation.*

In the first stage, spur gears have helical plastic impellers to achieve optimum noise suppression. The following gear stages are optimally designed with regard to running noise and the transmit-

ted torque. Hardened and ground output shafts and hardened gear wheels are standard in all Flatline and Compactline transmissions. Die-cast zinc is used as the housing material.

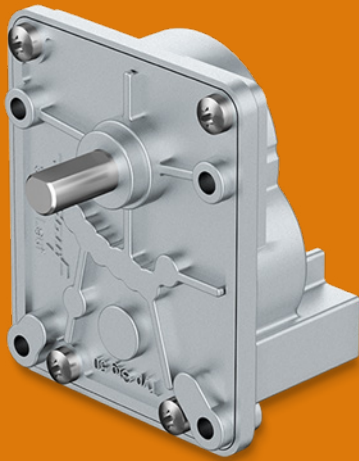

## **Flatline**

Flatline transmissions are designed for use in applications with a limited installation length.



## **Compactline**

The transmissions in the Compactline series are focused on the largest possible impeller width, particularly in the first stage, as a means of noise reduction. This ensures good overlap between the motor shaft and the intermeshing gear wheel.

### **Overall advantages:**

- Very high power density
- Compact, shallow design
- Broad range of reduction ratios
- Great radial loads permissible
- Good price-performance ratio

### **Two different product series:**

- Flatline
- Compactline

## Gearbox\*

			Compactline 90	Compactline 91	Compactline 92	Flatline 78	Flatline 85	
<b>Number of stages</b>								
2	Torque (M <sub>N</sub> )	Nm	up to 15	up to 15	up to 15	up to 30	up to 30	
	Reduction	r		7.80				
				9.20	15.5			
				11.1	18.4			
				18.8				
				26.8	13.8	23.1		
				30.6		31.1		
					27.6	40.1		
3	Torque (M <sub>N</sub> )	Nm	up to 15	up to 15	up to 15	up to 30	up to 30	
	Reduction	r			55.0		8.20	
				37.5	70.4		12.3	
					41.3	38.6	18.0	
				67.8	67.3	92.2	65.2	27.6
					117.1	142	82.8	40.3
				92.7	165.8	106.1	140.8	64.0
						184.4		101.8
				142.5		274.6		136.5
								189
								303.6
4	Torque (M <sub>N</sub> )	Nm	up to 15	up to 15	up to 15	up to 30	up to 30	
	Reduction	r					454	
				222			687	
				296		191.9	1028.7	
						252.6		
			432					
<b>Possible combinations with</b>								
<b>VD/VDC motors</b>								
VD/VDC-43.10								
VD/VDC-54.14								
VD/VDC-49.15								
<b>BCI motors</b>								
BCI-42								
BCI-52								
BCI-63								
Subject to change								

\* The overview of the transmissions shows all possible reductions. The combination of the necessary reduction with the desired motor is described in the catalogue and on the homepage and is available on request.

# Accessories:

## *Controllers, encoders, brakes.*

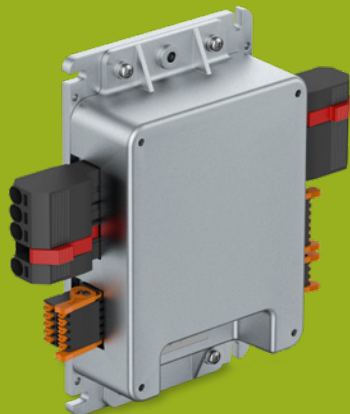

Electronics (external)

### Control electronics

- Integrated and external controllers for actuation of BLDC motors
- Versions for speed-controlled operation with analog set value requirement
- Versions for torque- and position-controlled operation
- Versions with CANopen and EtherCAT interface (DS 402 compatible)

### Encoder systems

- Magnetic and optical encoder systems, as well as absolute value encoders multiturn
- Encoders feature non-contacting operation and are wear-free
- Encoders are used in combination with suitable electronics for speed detection, speed control and positioning
- Counter buffering using the Wiegand effect

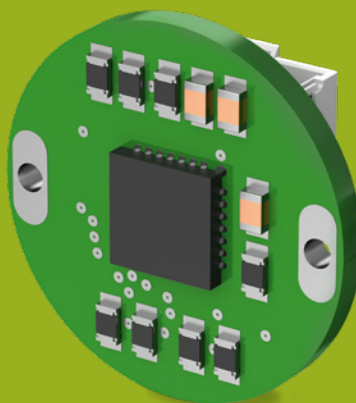

Incremental encoder (integrated)



Spring force brake (integrated)

### Brake systems

- Brakes based on the spring-applied brake principle
- Single-disk brakes with 2 friction surfaces
- Braking torque is built up when the power is switched off
- Brake is released by electromagnetic force
- Green Brake: innovative, de-energized brake with high power density, e.g. as a holding brake with emergency-stop function

### Control electronics

		K3 (integrated)	K4 (integrated)	K5 (integrated)	VTD-XX-XX-K3	VTD-XX-XX-K4S	VTD-60.13-K5SB	VTD-60.35-K5SB
Bus interface				CANopen			CANopen	CANopen
Nominal voltage	V DC	24/48	24/48	24/48	14 - 28	10 - 30	10 - 60	9 - 60
Speed control		●	●	●	●	●	●	●
Torque control			●	●			●	●
Position control			●	●			●	●

### Encoder systems

		PMG 2-12	PMG 2-2	HEDS 5500	PWB AE30	RM22 / RMC22
pulses per revolution	Z	12	2	512	512	1,024 (4,096)
Nominal voltage	V DC	24	24	24	24	5

Type		integrated RFK 0.3 Nm ECI 42 brake module	integrated RFK 1.0 Nm ECI 63 brake module	integrated RFK 1.0 Nm ECI 63 brake module	integrated RFK 2.0 Nm ECI 80 brake module
Nominal voltage	V DC	24	24	24	24
rated output	W	6	9	9	11.4
Braking torque	Nm	0.3	1	1	2
Closing, response time	ms	25	20	20	10
Opening time, release time	ms	85	60	60	58

Subject to change

# Contacts – *Worldwide*





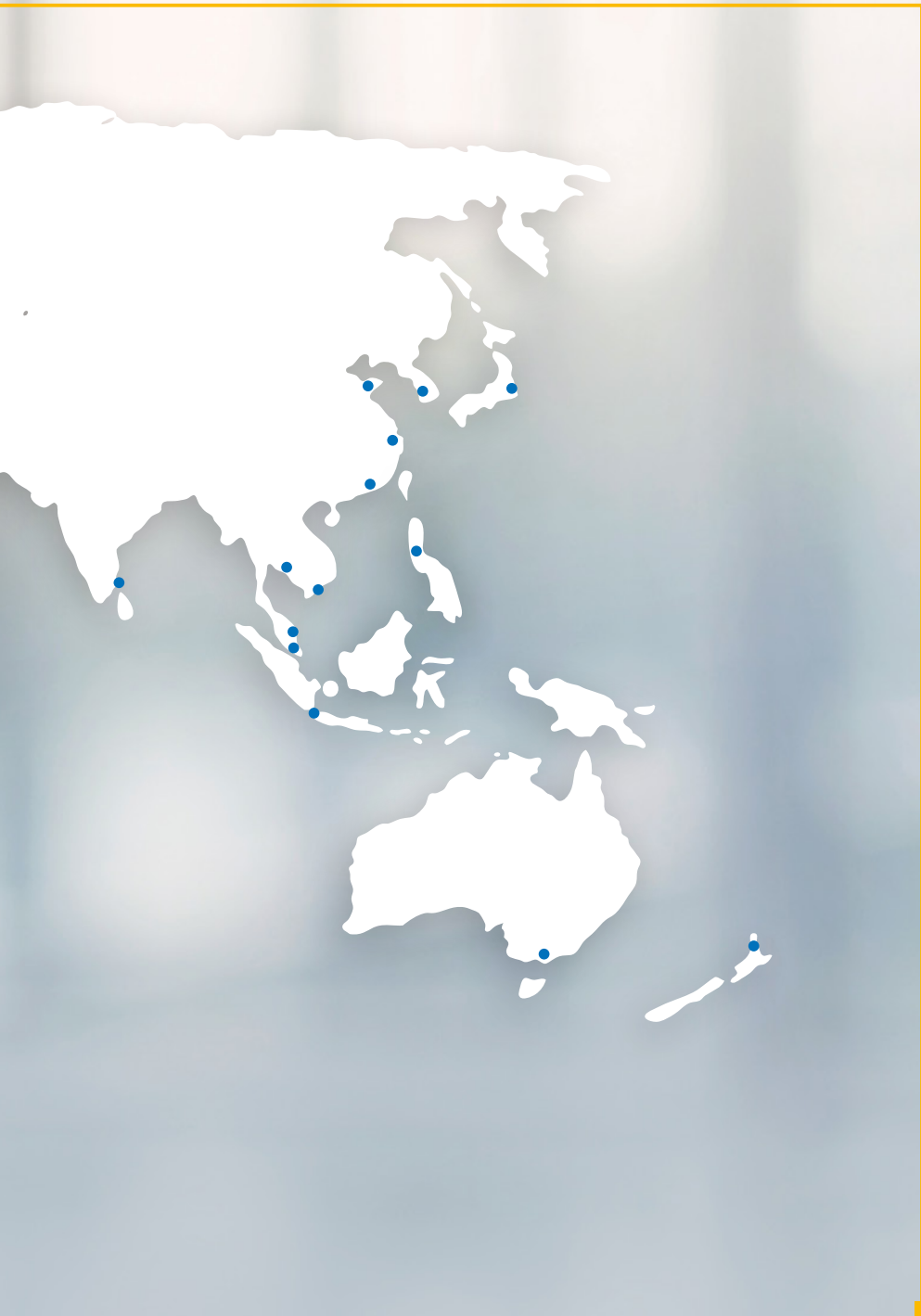

Germany

ebm-papst St. Georgen GmbH & Co. KG  
Hermann-Papst-Straße 1  
78112 St. Georgen  
GERMANY  
Phone +49 7724 81-0  
Fax +49 7724 81-1309  
info2@de.ebmpapst.com

ebm-papst St. Georgen GmbH & Co. KG  
Werk 7 Lauf  
Industriestraße 9  
91207 Lauf a. d. Pegnitz  
GERMANY  
Phone +49 9123 945-0  
Fax +49 9123 945-145  
info4@de.ebmpapst.com

*Always find the right  
contact person!*  
**[ebmpapst.com/contact](http://ebmpapst.com/contact)**

# GreenIntelligence. *Making Engineers Happy.*



Why do our customers look so happy? Because when it comes to digitalization and sustainability, we provide them with a clear competitive edge with GreenIntelligence. The intelligent control and networking of fans and drives makes applications more powerful and efficient. Together with a long product life and highly efficient EC technology, we achieve lasting reductions in energy costs and emissions.

For the wide range of automation tasks needed in industrial drive technology, what you need most is an experienced partner who understands your needs. The drive experts at ebm-papst have detailed applications expertise and, thanks to GreenIntelligence, can offer drive solutions with intelligent networking capabilities that cater for all requirements perfectly.

## Here is how much GreenIntelligence *there is in ECI Servomotors:*

- + Integrated logic & power electronics
- + Network functionality
- + Master/slave functionality
- + Condition monitoring
- + Predictive maintenance



# ebm-papst. Engineering a better life.

## Who we are.

With over 20.000 different products, ebm-papst offers the right solution for just about any challenge. As the logical next stage in the development of our highly-efficient GreenTech EC technology, we believe that industrial digitization offers the greatest future prospects for our customers. With GreenIntelligence, we already represent intelligently interconnected complete solutions that are unrivaled worldwide.

Because we are always committed to making each of our innovative hardware and software solutions more powerful, compact, efficient and sustainable than its predecessor, we have evolved over the years into the global technology leader for ventilation and drive technology.

## What drives us.

But our consistent pursuit of efficiency and progress has even deeper roots. After all, there is something that excites us even more than our market position. It is the deep awareness that, with our solutions, we are making the lives of many people around the globe more pleasant, safer and thus better. Therefore, the central driving force in all our thoughts and actions is Engineering a better life. It is the reason why it is worthwhile for us to get up every day and do our best.

More about this under [ebmpapst.com/betterlife](https://ebmpapst.com/betterlife)

**ebmpapst**

engineering a better life

## What you get out of it.

- 1. Technological edge.**  
With our EC technology and GreenIntelligence, we combine the highest energy efficiency with the advantages of IIoT and digital networking.
- 2. Our sustainable approach.**  
We take our responsibility seriously with energy-saving products, environmentally-friendly processes and through social engagement.
- 3. System expertise.**  
As experts in advanced drive technology, electronics and aerodynamics, we provide perfect system solutions from a single source.
- 4. The ebm-papst spirit of invention.**  
Over 800 engineers and technicians will develop a solution that precisely fits your needs.
- 5. Personal proximity to you.**  
Thanks to numerous sales locations worldwide.
- 6. Our standard of quality.**  
Our quality management is uncompromising, at every step and in every process.

Anna exploits the possibilities of the Industrial Internet of Things throughout the logistics and production processes.

GreenIntelligence helps us turn our commitment to *Engineering a better life* into reality.

What exactly does this mean? Watch the video now:



[www.ebmpapst.com](http://www.ebmpapst.com)

**ebmpapst**

engineering a better life

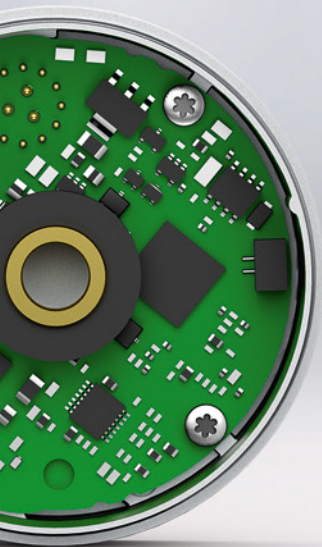

**ebm-papst St. Georgen  
GmbH & Co. KG  
Hauptverwaltung**

Hermann-Papst-Straße 1  
78112 St. Georgen  
Germany  
Phone +49 7724 81-0  
Fax +49 7724 81-1309  
[info2@de.ebmpapst.com](mailto:info2@de.ebmpapst.com)

**ebm-papst St. Georgen  
GmbH & Co. KG  
Werk 7 Lauf**

Industriestraße 9  
91207 Lauf a. d. Pegnitz  
Germany  
Phone +49 9123 945-0  
Fax +49 9123 945-145  
[info4@de.ebmpapst.com](mailto:info4@de.ebmpapst.com)