

EC centrifugal blowers with high power density.

Innovative and unique.

ebmpapst

The engineer's choice



About ebm-papst.

As a leader in technologies for ventilation and drive engineering, ebm-papst is in demand as an engineering partner in many sectors. With over 15,000 different products, we provide the right solution for just about any challenge. Our fans and drives are reliable, quiet and energy-efficient.



Six reasons that make us the ideal partner:

Our systems expertise. As experts in advanced motor technology, electronics and aerodynamics, we provide system solutions from a single source.

Our spirit of invention. Our 600 engineers and technicians will develop a solution that precisely fits your needs.

Our lead in technology. Our GreenTech EC technology is setting standards worldwide. And our lead is your competitive advantage.

Proximity to our customers. At 57 sales offices worldwide.

Our standard of quality. Our quality management is uncompromising, at every step in every process.

Our sustainable approach. We assume responsibility with our energy-saving products, environmentally-friendly processes, and social commitment.

The air curtain principle.

Air curtains are used wherever cold air needs to be separated from warmer air. In just a matter of seconds, they generate a wall of air that prevents cold air from mixing with the warm air in adjoining areas, for example in cold storage rooms or at goods reception.



Lifecycle costs can also be significantly reduced thanks to the GreenTech EC technology and system solution:

- Quick and simple start-up
- Highly efficient GreenTech EC motor that even surpasses the IE4 efficiency class
- Average of **37%** less energy consumption than AC technology

Further areas of application: Personnel airlocks.

In personnel airlocks, a strong air flow is quickly generated to decontaminate clothes in no time at all. Here, the EC centrifugal blowers developed by ebm-papst demonstrate their real superiority: They start up at least as fast as conventional AC versions, however are significantly more energy-efficient as the graph on page 3 illustrates.

Modular and freely scalable.

Flexibility rules. That's why EC centrifugal blowers from ebm-papst can be modularly expanded. Even the parallel connection of fans is no longer a problem thanks to the Active PFC. The result is that virtually every customer desire can be fulfilled.

All of our customer benefits at a glance:

- Modular connection or structure possible – you can expand your air curtain at any time
- Quick start-up
- Standards-compliant parallel connection through Active PFC
- High power density
- Reliable operation even at high temperatures
- Impeller, motor, control electronics, and housing as a compact unit, system concept, plug & play

Always under control.

Straight to high power density.

See for yourself: The new EC centrifugal blowers from ebm-papst start up faster than conventional EC models, while operating considerably quieter and with greater energy efficiency. The “heart” of this speedy starter, available in fan sizes 160 and 250, is a GreenTech EC motor with a power of 0.75 kW. The chart on the right shows the start-up time to reach the max. speed.

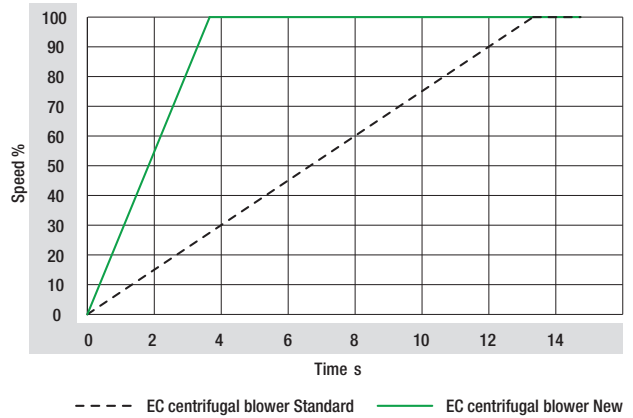

Optimised operation.

Benefit from newly developed electronics with Active Power Factor Correction in the power range up to 750 W: Active PFC filters out unwanted harmonics and helps to achieve excellent power factors of up to $\lambda = 0.99$. Current peaks are also reduced by up to 50%. The connection of several fans in parallel is then no problem. Active PFC from ebm-papst thus opens up completely new perspectives for operating air conditioning systems!

Example

Without Active PFC

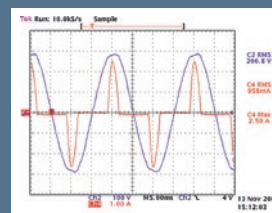

Power factor $\lambda = 0.53$

With Active PFC

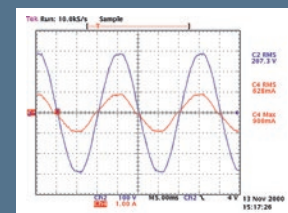

Power factor $\lambda = 0.99$



The advantages of a new idea.

It used to be that AC fans were typically used in applications, however since 2015 these often no longer meet the applicable requirements of the ErP Directive (ecodesign directive). There is now an alternative for such applications that complies with the ErP directive: Energy-efficient EC centrifugal blowers reach full blast at lightning speed and offer numerous additional advantages.

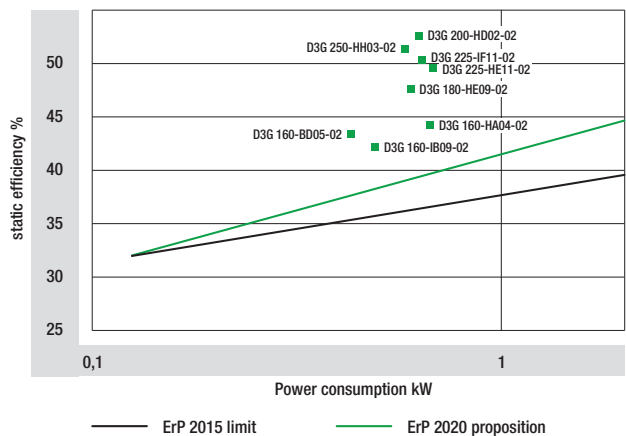

Holds its own.

All of our product benefits at a glance:

- Air flow up to 3,000 m³/h
- Robust sheet steel
- Compact design thanks to external rotor motor
- Forced electronics cooling
- Consistent series for every application
- 100 % speed control through analog or serial interface
- Simple start-up thanks to perfectly matched components:
open loop control, motor, fan
- Plug & play

A clear project is a good project.

Regardless of the project you have planned, with the new EC centrifugal blowers from ebm-papst you will be utilizing cutting-edge technology and profiting from maximum flexibility in your systems. This also applies to our cooperation as a partner. Looking for support or precise tender specifications for a project? Help is a click away:

www.ebmpapst.com/forwardcurved

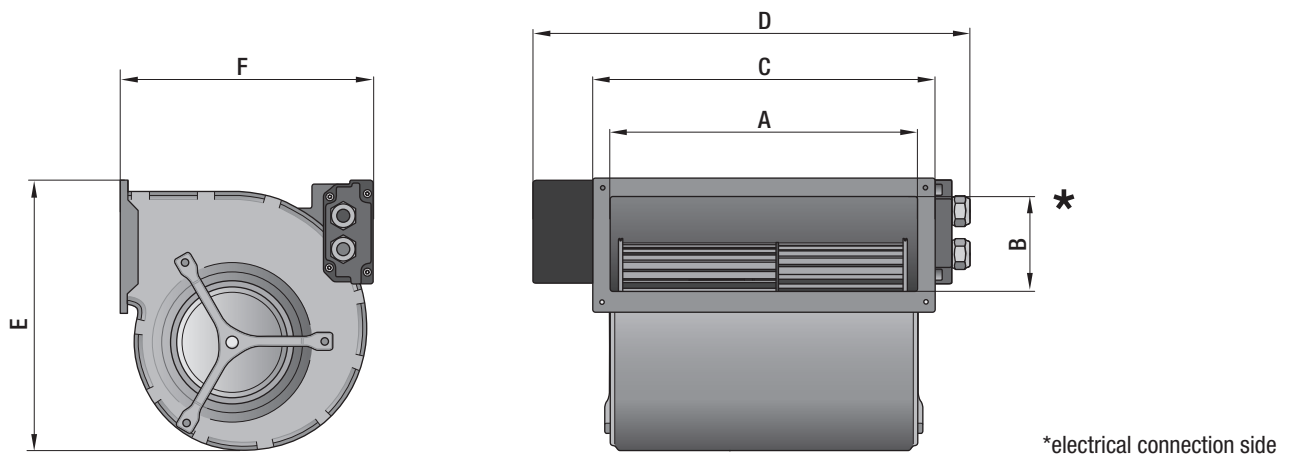

*electrical connection side

Article number	A	B	C	D	E	F
D3G 160-BD05-02	232	103	270	391	260	234
D3G 160-HA04-02	232	107	270	391	260	233
D3G 160-IB09-02	274	107	314	391	260	233
D3G 180-HE09-02	255	134	309	391	395	296
D3G 200-HD02-02	287	146	341	391	397	328
D3G 225-HE11-02	333	146	387	–	397	328
D3G 225-IF11-02	287	146	341	391	394	328
D3G 250-HH03-02	298	167	349	–	417	388

All dimensions in mm. Data sheets available upon request. Data is subject to change without notice at ebm-papst discretion.

All in all: Leading the way.

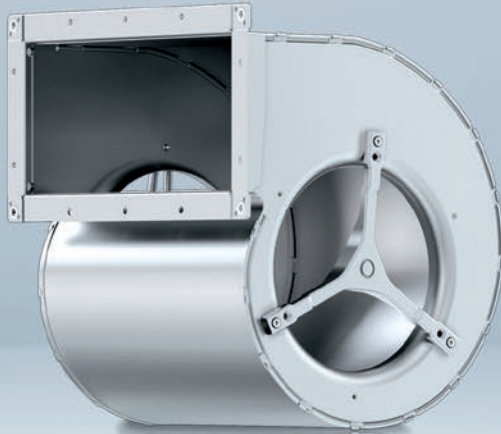

Housing

- + Robust design**
 - Solid steel housing/industrial design
 - Aerodynamic housing contour
 - Proven, durable construction
 - Galvanized sheet steel, corrosion-resistant
- + Flexible installation**
 - Installation with horizontal and vertical motor shaft
- + Simple mounting**
 - Housing with discharge flange
 - Industry standard connection dimensions (simple 1:1 conversion)

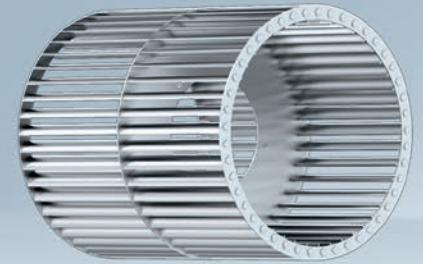

Impeller

- + Robust design**
 - Galvanized sheet steel
- + Quiet operation**
 - Impeller rotor unit dynamically balanced in two planes
 - High balance quality
- + High efficiency**
 - Optimized aerodynamics
- + Flexible design**
 - Increased air flow through parallel connection





GreenTech EC motor

- + Economical operation**
 - Low copper and iron losses
 - No slip losses through synchronous running
 - No magnetic hysteresis losses in the rotor through the use of permanent magnets
 - High partial load efficiency
- + Low sound emissions**
 - Optimized control and adapted stator design
 - Noise-optimized commutation
- + Safe operation**
 - Insulated bearing system to prevent bearing currents
 - Enables partial load operation up to 1:10



Active PFC

Active power factor correction minimizes disturbing harmonics, achieves power factor of $\lambda = 0.99$

Electronics

- + High static efficiency**
 - No adjustment effort as motor, electronics, and control from a single source
 - Central plug-in area for power and control inputs
 - Compact design through optimized cooling of power electronics
 - No parameter setting required during start-up
 - Safe separation between terminal area and electronics
- + Flexible open loop control**
 - Smoothly adjustable speed
 - Control via 0–10 V/PWM and MODBUS-RTU
 - Error message output
 - Interface with SELV
- + Safe operation**
 - Locked rotor and thermal overload protection
 - Disconnection in case of malfunction
- + Universally deployable**
 - For use with 50- and 60-Hz grids
 - Electronics with IP54 protection
 - Extended voltage input 1 ~ 200 V – 277 V



Big performance.

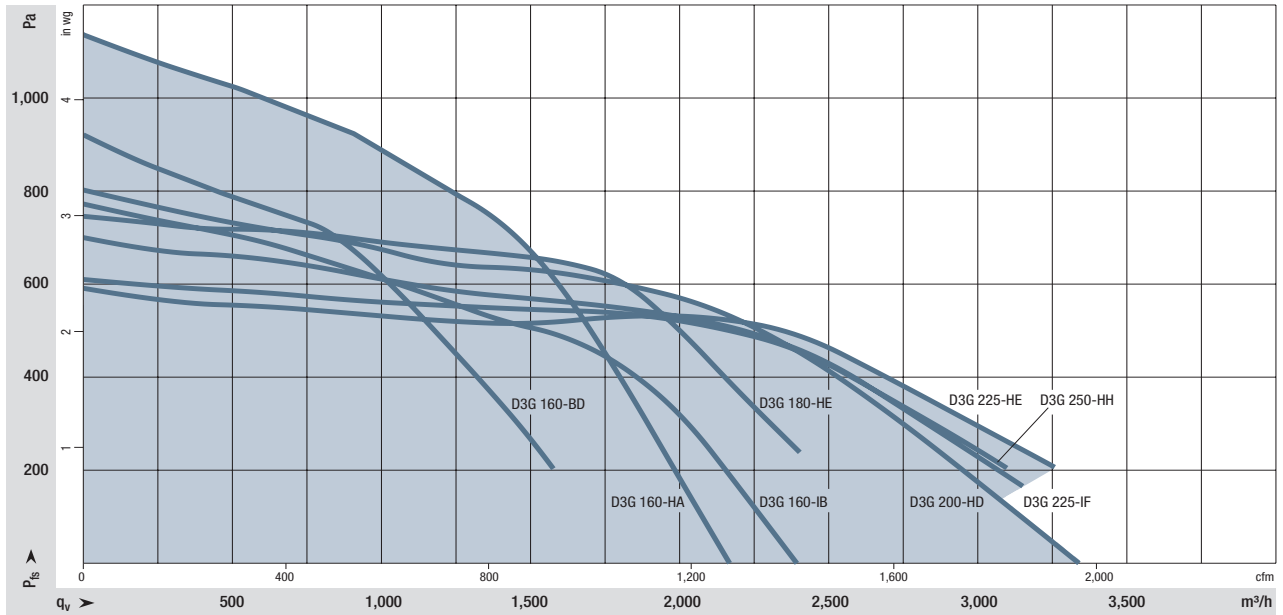

Fan power measurements are carried out on state-of-the-art chamber test rigs. The entire fan unit, consisting of motor, control electronics, and impeller, is measured at varying load states. This ensures that we obtain reliable data, and that you can count on these values being reached when selecting a fan. There are therefore no nasty surprises in store when starting up the fans.

The measured data forms the basis for our design program, which is available upon request. This software can be used to calculate the expected operating costs or to perform lifecycle cost analyses.

Nominal data fans		Nominal voltage	Nominal voltage range	Frequency	Speed	Max. input power	Max. input current	Perm. ambient temperature	Weight
Article number	Motor	VAC	VAC	Hz	rpm	W	A	°C	kg
D3G 160-BD05-02	M3G074-DF	230	1 ~ 200-277	50/60	2,240	430	2.0	-25...+50	6.5
D3G 160-HA04-02	M3G084-DF	230	1 ~ 200-277	50/60	2,380	750	3.3	-25...+50	7.8
D3G 160-IB09-02	M3G084-FA	230	1 ~ 200-277	50/60	2,230	750	3.3	-25...+50	8.5
D3G 180-HE09-02	M3G084-FA	230	1 ~ 200-277	50/60	2,110	750	3.3	-25...+50	9.7
D3G 200-HD02-02	M3G084-GF	230	1 ~ 200-277	50/60	1,570	750	3.3	-25...+50	11.1
D3G 225-HE11-02	M3G084-GF	230	1 ~ 200-277	50/60	1,420	750	3.3	-25...+50	12.0
D3G 225-IF11-02	M3G084-GF	230	1 ~ 200-277	50/60	1,430	750	3.3	-25...+50	12.5
D3G 250-HH03-02	M3G084-GF	230	1 ~ 200-277	50/60	1,310	750	3.3	-25...+50	12.2

Data sheets available upon request. Data is subject to change without notice at ebm-papst discretion.

ebm-papst
Mulfingen GmbH & Co. KG

Bachmühle 2
74673 Mulfingen
Germany
Phone +49 7938 81-0
Fax +49 7938 81-110
info1@de.ebmpapst.com

ebmpapst

The engineer's choice