

# Operating Manual Instructions

Modbus Monitor & Control Unit  
CN1127 - 8217139626

**ebmpapst**

engineering a better life

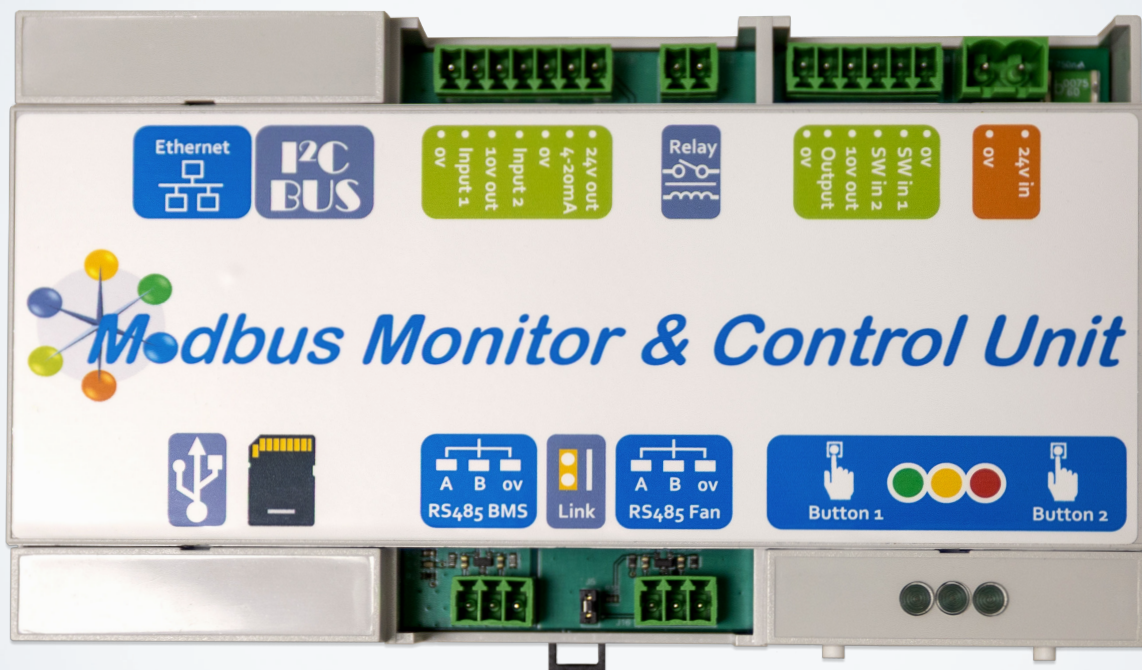



## Contents

List of Tables .....	3
List of Figures .....	3
1.0 General notes .....	4
1.1 Exclusion of liability .....	5
1.2 Introduction .....	5
2.0 Safety notice .....	5
3.0 Overview .....	6
3.1 Specification.....	6
3.2 Installation.....	6
3.3 Hot plugging.....	6
3.4 RS485 wiring.....	6
4.0 Configuration and first use .....	8
4.1 Electrical connections .....	8
4.2 Initial power ON .....	10
4.3 First time configuration .....	10
4.3.1 Wi-Fi setup .....	10
4.3.1.1 Updating default Wi-Fi password .....	10
4.3.2 Ethernet setup .....	10
4.3.3 Device Setup .....	11
4.3.4 Configuring a fan array .....	12
4.3.5 Fan addressing – Configure fan communications .....	12
4.3.6 Fan addressing – Configure external Modbus communications .....	13
4.3.7 Fan addressing – auto addressing (Serial no. based addressing).....	14
4.3.7.1 Finding an existing fan network.....	14
4.3.7.2 Auto address fans .....	14
4.3.8 Re-ordering fans .....	15
4.3.8.1 Visual Re-ordering .....	15
4.3.8.2 DCI Reordering .....	16
4.3.9 Fan Grouping.....	17
5.0 Operating modes .....	18
5.1 Overview .....	18
5.2 Monitor mode .....	20
5.3 Webserver control mode .....	21



5.4 Proportional control mode .....	22
5.5 Constant Volume / Pressure mode.....	24
5.6 Multi source control mode .....	25
5.7 Group 2 offset / Independent.....	28
5.8 Summary Page .....	29
5.9 Fan Status Page .....	30
6.0 Pressure sensor connections .....	31
6.1 Sensor configuration .....	32
6.2 Sensor wiring and airline connections .....	32
6.3 Choosing the pressure sensor range for constant volume.....	34
6.4 Sensor mapping.....	35
7.0 Advanced settings.....	36
7.1 Communication Settings for Fans .....	36
7.2 Communication Settings for BMS.....	36
7.3 System Reset & Reboot.....	37
7.4 Fan Speed Cap (0-100%) .....	37
7.5 Controller Input Cap (0-100%).....	38
7.6 External Switch Input 1 Enable / Disable Fans .....	38
7.7 External Switch Input 2 Setpoint 1 / Setpoint 2.....	39
7.8 PID values.....	39
7.9 0-10V Output Follower .....	40
7.10 System Units.....	40
7.11 Relay Configuration.....	40
7.12 Controller Detected Warnings .....	41
7.13 Resonance Avoidance .....	42
7.14 Fan Communications Diagnostics .....	44
7.15 Expansion Modules.....	44
7.16 Device Assessment.....	45
7.17 Customer Information.....	46
7.18 Device Information .....	46
7.19 Firmware Update .....	47
8.0 LED Alarm / Warning indications .....	47
9.0 Replacing the controller .....	48
10.0 Replacing a fan.....	48
11.0 Device Factory Reset .....	48
12.0 Dimensions.....	49
13.0 WEEE (Waste Electrical and Electronic Equipment).....	50
14.0 End of life .....	50



15.0 Take back policy.....	50
16.0 Transport & Storage .....	50
17.0 Maintenance and servicing .....	50
18.0 CE Certificates.....	51
Appendix A.....	51
A.1 Proportional Control Graph.....	51
A.2 Constant Volume strategy based on Backward curved centrifugal fan .....	52
A.3 Constant Volume with capped fan speed based on Backward curved centrifugal fan.....	53
A.4 Dual setpoint.....	55
Appendix B.....	56
B.1 Modbus holding registers for site design .....	56
B.2 Modbus holding registers for system configuration and control .....	56
B.3 Modbus holding registers for remote system overview .....	58
B.4 Modbus holding registers for individual fan monitoring .....	59
B.5 Fan Alarm and Warning Register .....	61
B.6 Fan Vibration Sensor Status Register .....	62
B.7 Modbus Direct fan access .....	63
Appendix C.....	64
C.1 Change notes v2.0.0 .....	64

## List of Tables

Table 1 - Specification information.....	6
Table 2 - Connection details top row.....	8
Table 3 - Connection details bottom row.....	9
Table 4 - Communication setup for fans .....	12
Table 5 - Communication setup for external device .....	13
Table 6 - Operation mode options .....	19
Table 7 - Group summary headings.....	29
Table 8 - Fan status headings .....	30
Table 9 - LED indication codes .....	47
Table 10 - Site design holding registers.....	56
Table 11 – System configuration and control holding registers .....	57
Table 12 - System data holding registers.....	58
Table 13 - Locally stored fan data holding registers.....	59
Table 14 - Fan alarm & warning registers .....	61
Table 15 – Fan vibration sensor status register .....	62
Table 16 - Modbus Direct fan access holding registers.....	63

## List of Figures

Figure 1 - RS485 connections - MMCU one end.....	7
Figure 2 - Link Bar removal .....	7
Figure 3 – Daisy chain reordering extra fan connection .....	16



Figure 4 - Example 0-10v potentiometer input ..... 23

Figure 5 – Example pressure sensor connection to controller..... 24

Figure 6 - Switch between two setpoints..... 24

Figure 7 - Example BMS connection..... 26

Figure 8 – Offset example for Group 2..... 28

Figure 9 - Pressure sensor connections. .... 31

Figure 10 - Connecting to tapping rings for Volume measurement. 31

Figure 11 - Example connection of pressure sensor connected to a fan Vout supply.....32

Figure 12 – Example connection of pressure sensor connected to a separate power supply.....33

Figure 13 - Installation of multiple pressure sensors for Volume measurement .....33

Figure 14 - installation of multiple pressure sensors for Pressure measurement .....33

Figure 15 - Volume measurement set up with multiple fans connected to one sensor. ....35

Figure 16 - Enable / Disable switch .....38

Figure 17 - Setpoint toggle switch.....39

Figure 18 - Resonance avoidance speed mask pre-step change.....43

Figure 19 - Resonance avoidance speed mask post-step change .....43

 **Important** 

**To assure proper usage, we ask you to read these operating instructions carefully before installation and commissioning of the control device.**

 **NOTE:** The table below identifies the features compatible with your controller’s firmware issue number. This is shown in the configuration app when connected and on the label at the back of the printed circuit board.

Firmware Issue	Notes
2.0.0	As per this OMI release, refer to Appendix C for change notes.
Previous	As per previous OMI release(s)

## 1.0 General notes

Before installation and start-up of the MMCU, please read this OMI carefully to ensure correct use. This OMI applies only to the MMCU and not for the complete system it is connected to. It is recommended to keep a copy of these operating instructions together with the device. It must be ensured that all persons that are to work on the device can refer to the operating instructions at any time.



## 1.1 Exclusion of liability

To allow for future developments, in fan technology and controller refinements, any technical data given here is subject to alteration. We do not accept any liability for possible errors or omissions in the information contained in the data, illustrations or drawings provided. We accept no liability for damage caused by misuse, incorrect use, improper use or as a consequence of unauthorised repairs or modifications.

## 1.2 Introduction

The Modbus Monitor & Control Unit (MMCU) is a device with two RS485 ports for accessing the status of the connected equipment. The 'RS485 fan' port communicates with ebm-papst Modbus enabled, Electronically Commutated (EC) fans with software version 5.0 or later using a two-wire plus ground RS485 connection. The 'RS485 BMS' port communicates with an external Modbus Master device e.g., Building Management System (BMS) and provides real-time monitoring and control data.

The MMCU features a Modbus auto-addressing program to ease installation and commissioning where it automatically searches and addresses up to 99 of the same generation EC fans connected to its 'RS485 fan' port.

Five different operating modes are supported, Monitor, Fixed speed, Proportional control, Multi source and Constant Volume / Pressure.

## 2.0 Safety notice

### **⚠ CAUTION – Safety**

The Modbus Monitor & Control Unit (MMCU) is only suitable for a safety extra low voltage supply of 24VDC up to 57VDC or 24VAC. An isolated voltage supply is recommended to be used.

### **⚠ CAUTION – Electro-Static Discharge**

Many modern electronic components are susceptible to damage from Electro-Static Discharge (Static Electricity). During programming and commissioning, avoid unnecessary contact with electronic components on PCBs. PCBs are sensitive to static discharges so should be stored and transported in anti-static packaging until they are required to be used.

### **⚠ Warning – Do not operate in an explosive atmosphere.**

**⚠ Warning – The fans may start during connection and programming. If there is a residual risk of contact with a fan, then contact shall be prevented by suitable control methods to prevent accidental contact.**



### 3.0 Overview

### 3.1 Specification

<b>Product</b>	Modbus Monitor & Control Unit - CN1127
<b>Supply Voltage (Reverse Polarity Protected)</b>	24 VDC nominal (12 to 57VDC) from an external PSU or 24 VAC nominal (20 to 28VAC) from an external transformer
<b>Supply Current</b>	Max 200mA
<b>Enclosure</b>	DIN rail mount IP20
<b>Enclosure Dimensions</b>	See Section 12.0
<b>Weight</b>	165 g
<b>Operating Environment</b>	-20°C to +60°C, 90%RH at 40°C max.
<b>EMC Compliance</b>	EN61000-6-3 (emissions) EN61000-6-1 (immunity) EN301-489-1
<b>Safety Compliance</b>	EN62368-1
<b>Radio Compliance</b>	EN300-328
<b>Security Compliance</b>	EN18031-1

Table 1 - Specification information

### 3.2 Installation

Avoid exposure to vibration, high temperatures. The unit shall be installed according to relevant safety guidelines and requirements. Attention should be paid to local regulations and guidance.

### 3.3 Hot plugging

Hot plugging the controller is permissible, however, if a new or replacement controller is not at factory default settings, it will need to be reset to such.

### 3.4 RS485 wiring

For reliable communication with the fans, it is recommended to use shielded twisted pair cable with 120Ω impedance (RS485 standard cable), in a “Daisy Chain” wiring layout, run separate from mains supply wiring. We recommend placing the controller at one end of the RS485 network and to add a 220Ω termination resistor at the other end of the network.

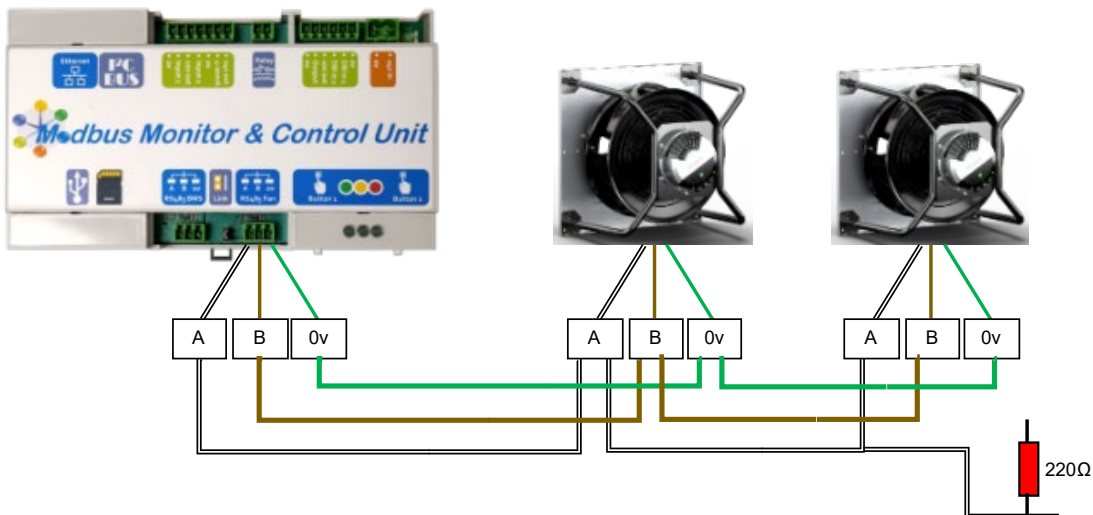

Figure 1 - RS485 connections - MMCU one end

In case the controller is in the middle of the network, the built-in termination resistor must be taken out of the circuit by removing the 'Link bar' located on the PCB. Two resistors of the same value must be added at each end of the network.

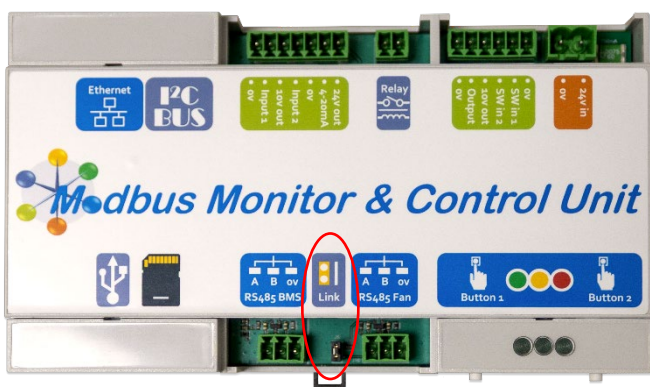

Figure 2 - Link Bar removal

## 4.0 Configuration and first use



### 4.1 Electrical connections

Connection	Pin	Description	Function
<ul style="list-style-type: none"> <li>• 24v in</li> <li>• 0v</li> </ul>	24V DC in	Or 24v AC ~	Power in
	0V (GND)		
<ul style="list-style-type: none"> <li>• 0v</li> <li>• SW in 1</li> <li>• SW in 2</li> <li>• 10v out</li> <li>• Output</li> <li>• 0v</li> </ul>	0V	Common 0V GND	Ground reference for switch inputs
	SW in 1	Switch input 1	Active low Fan enable / Disable (pulled up internally)
	SW in 2	Switch input 2	Active low Setpoint toggle (pulled up internally)
	10v out	10VDC output	Reference for control inputs
	Output	0-10v control output	Follower output for external device control 50mA rating
	0V	Common 0V GND	Ground reference for switch inputs
	Com	Common relay contact	Configurable alarm output relay 60VDC 0.1A rating
	NC	Normally closed relay contact	
<ul style="list-style-type: none"> <li>• 24v out</li> <li>• 4-20mA</li> <li>• 0v</li> <li>• Input 2</li> <li>• 10v out</li> <li>• Input 1</li> <li>• 0v</li> </ul>	24V out	24VDC output	Reference for powering a sensor. 0.05A rating
	4-20mA	4-20mA input	Current input from external sensor
	0V	Common 0V GND	Ground reference for control inputs
	Input 2	0-10V control input	Control input from external sensor or potentiometer
	10V out	10VDC output	Reference for control inputs
	Input 1	0-10V control input	Control input from external sensor or potentiometer
	0V	Common 0V GND	Ground reference for control inputs
	I <sup>2</sup> C Bus	Auxiliary device connection	Wi-Fi expansion module or future I <sup>2</sup> C devices
	Ethernet	LAN or Internet connection	LAN - alternative to Wi-Fi connection Internet – Dashboard, HMI

Table 2 - Connection details top row



Connection	Pin	Description	Function
	Button 1	Wake up Wi-Fi	Press & hold for 3 secs
	Green	Good / powered	LED indicator for good operation - Flashing
	Yellow	Warning	LED indicator for Warnings
	Red	Alarm	LED indicator for Alarms
	Button 2	Software Reset	Press & hold for 3 secs
		A	RS485 'A' pin
B		RS485 'B' pin	
0V		Common 0V (GND)	
	Link	Removable link	Removing internal termination resistor when MMCUC is in the middle of a fan network. See 3.4
	A	RS485 'A' pin	RS485 connection from 3 <sup>rd</sup> Party system e.g. BMS
	B	RS485 'B' pin	
	0V	Common 0V (GND)	
	Micro SD Card	Firmware updates	Firmware updates / future logging capability
	Micro USB	Only used for programming	

Table 3 - Connection details bottom row

**⚠ CAUTION:** The controller cannot be powered by the fans Vout connection. It requires a separate power source.



## 4.2 Initial power ON

When power is applied, all three LEDs will come on briefly and then the green light will blink slowly to confirm power is applied. In case the ethernet cable is connected to the controller, the green light will stay solid. The controller will check the on-board memory for a previously stored fan array and configuration. If there is no previously stored information, please follow the first-time configuration instructions.

## 4.3 First time configuration

**⚠ Note:** Ensure your device settings allow for automatic proxy. Some devices may try and automatically connect to the internet when opening the browser and using Wi-Fi. This should be deactivated to ensure the Webserver page can load from the MMCU.

### 4.3.1 Wi-Fi setup

Once powered, press and hold 'Button 1' until the Green LED starts blinking at a faster interval, which wakes up the Wi-Fi connection. Using a Wi-Fi enabled phone, tablet or laptop open Wi-Fi settings and look for "MMCU". Select the device and enter **mmcu1234** to connect when prompted. Once connected the green LED will be solid. Open a browser of your choice and connect to the webserver using <http://192.168.4.1>.

#### 4.3.1.1 Updating default Wi-Fi password

When connecting via Wi-Fi for the first time, on loading a webserver page, a dialog box is shown prompting a password change, in line with the latest cybersecurity regulations. Enter a custom password, minimum 12 characters and press confirm. The device will stop active Wi-Fi connection and restart the Wi-Fi hotspot. Connect to the device using the new custom password. This password cannot be changed, and if forgotten, the device must be reset to factory default settings, refer to Section 7.3 for more information.

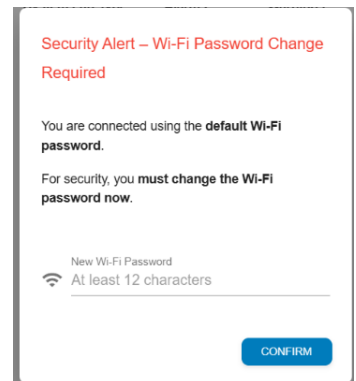

### 4.3.2 Ethernet setup

Once powered, connect a laptop directly to the MMCU using an Ethernet cable. Now open your browser and connect to the webserver using <http://192.168.1.1>.

If a recommended HMI is used, then connecting with the Ethernet cable will connect directly.

MMCU: epUK p/n CN1127 – epM p/n 8217139626

### 4.3.3 Device Setup

The start setup screen is only shown if the controller has no previous saved configuration or if the controller has been factory reset.

Click “Start Setup” to begin the setup process.

If a device firmware update is required, click “Update Firmware” button, then refer to Section 7.18 for further instructions.

The entered device name will be assigned as the Wi-Fi name, i.e. “Controller 1”, which will be displayed instead of “MMCU xx:xx:xx:xx:xx:xx” for future connection.

The Device Serial no. can be found on the controller label giving week and year of manufacturer plus a unique 4-digit identifier. The serial number is 8 digits long.

Enter a password and then re-enter to confirm. The password must be between 12 and 20 characters in line with the latest cybersecurity regulations.

The entered password will be saved in the MMCU’s memory and will be required to be entered on each connection to the MMCU. This password gives full access to MMCU’s features and settings.

If the password is not entered, MMCU can be used in monitoring mode only, i.e., checking group and fan status on the live status page.

When the device setup is complete, the device name will change from MMCU to the entered device name, which can be seen at the top of the page.

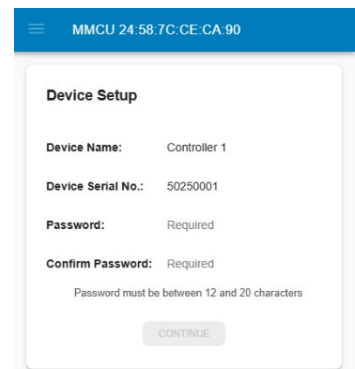
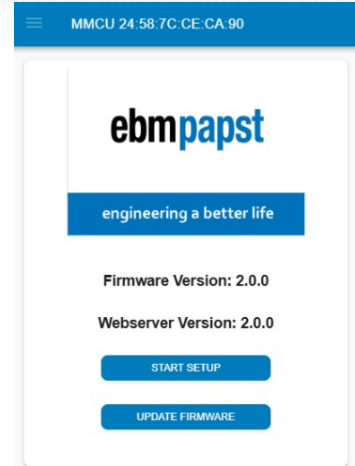

**⚠ Note:** If the password or device name is forgotten access can only be made by carrying out a Hard reset. See section 11.0



### 4.3.4 Configuring a fan array

The controller can be used on a new installation with fans delivered in their factory default condition (Modbus address 1 default) or be used on an existing array of fans which have been networked and pre-addressed (sequentially from Modbus address 2 onwards). If the controller is used in a fan array previously configured by another device, in most cases it is only required to use the controller’s “Factory Reset” option in the advanced menu before configuring the controller and fans.

### 4.3.5 Fan addressing – Configure fan communications

New fans are supplied from the factory as Modbus address 1 with 19200 baud rate, even parity and 1 stop bit. New controllers are supplied without any stored fan array configurations and on first application of power to the controller, the default values are suggested on the Fan addressing screen. These can be kept, or new parameters can be selected.

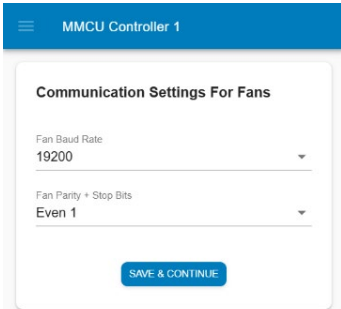

1200	2400	4800	9600		Even 1 default	Odd 1
19200 default	38400	57600	115200		None 1	None 2

Table 4 - Communication setup for fans

The LEDs will pulse Red and Green 1sec on/off (See table 9)

Pressing ‘Save & Continue’ to save the entered settings or default settings if nothing has changed.

**⚠ Note:** The Modbus Port Configuration must be the same across all fans in the network.  
For fans that are not at their default Modbus Address 1, the controller is able to reset all connected fans to that address using the “Factory Reset” option.

4.3.6 Fan addressing – Configure external Modbus communications

For communication with an external system e.g. BMS you can configure the Modbus RTU communication settings in a similar way to the fan.

1200	2400	4800	9600		Even 1 default	Odd 1
19200 default	38400	57600	115200		None 1	None 2

Table 5 - Communication setup for external device

The recommended controller response time to Modbus Master requests is 1 second.

You can also set the Modbus address for the controller so multiple controllers can be seen by the external device / BMS.

If Modbus TCP is required, select the checkbox and configure an IP address, subnet mask and port as required.

Set the BMS password for extra security. The entered value will be stored in the controller’s non-volatile memory. The BMS Password Register value (refer to Appendix B.2, Table 11) must match to the BMS password value configured via the webserver before you can change any register value via the BMS. If this feature is not required, leave as 0.

Pressing the ‘Back’ button returns to the previous page, ‘Save & Continue’ to save the entered settings or default settings if nothing has changed.



MMCUC Controller 1

**Communication Settings For BMS**

Modbus RTU  Modbus TCP

BMS Baud Rate  
19200

BMS Parity - Stop Bits  
Even 1

Controller Modbus Address  
1

BMS Password  
0

BACK SAVE & CONTINUE

**Communication Settings For BMS**

Modbus RTU  Modbus TCP

IP Address  
192.168.1.1

Subnet Mask  
255.255.255.0

Port  
502

BMS Password  
0

SET

**⚠ Note:** If Modbus TCP is selected, the Controller must be restarted after finishing the configuration to enable Modbus TCP.

MMCU: epUK p/n CN1127 – epM p/n 8217139626

### 4.3.7 Fan addressing – auto addressing (Serial no. based addressing)

When new fans are supplied from the factory, they will all have the Modbus address 1 as default. These will need to go through an auto address process (See 4.3.7.2). If a fan or fans have been auto addressed before they will have a Modbus address from 2 onwards and a group will consist of sequentially increasing Modbus addresses with no gaps. This therefore constitutes an existing fan network. (see 4.3.7.1).

#### 4.3.7.1 Finding an existing fan network

Select “Find Existing Fan Network”. The controller will start searching for fan Modbus Addresses 2-99.

If after 1 minute the controller cannot find an existing array of fans it will advise to check the network wiring and power and then return to the addressing menu to try again.

If the fans have been detected and verified, the Controller will display the result and ask for confirmation.

#### 4.3.7.2 Auto address fans

Select “Auto address fans”. The controller will verify and display how many fans it has detected and then ask for confirmation. The yellow light will flash briefly as a fan is found. (See Table 9). If after 1 minute the controller cannot find any fans, it will advise to check the network wiring and power and then return to the addressing menu to try again.

The fan addressing is performed in ascending order, where fans with the lowest serial number have the lowest Modbus Address and Fan Number assigned by

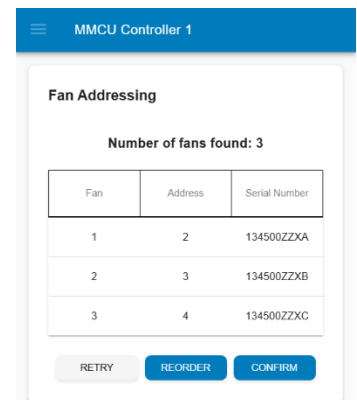
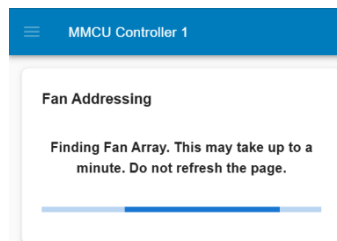
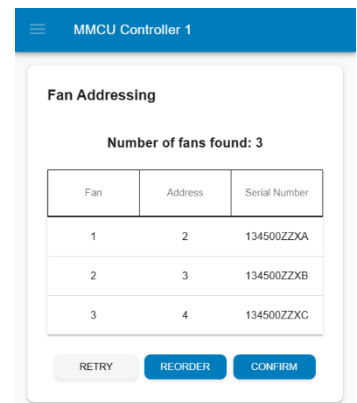
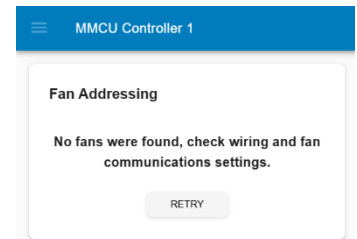
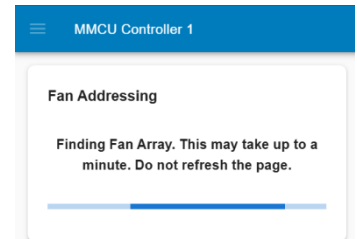
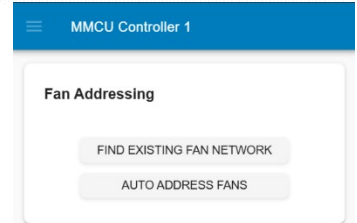

MMCU: epUK p/n CN1127 – epM p/n 8217139626

the controller. The first assigned Modbus Address to a fan is always 2. See an example below of a fan array consisting of 3 fans:

*Fan Z has Serial Number 1327006PDZ – Controller Assigns Modbus Address 2 – this is FAN 1.*

*Fan X has Serial Number 1527006PDS – Controller Assigns Modbus Address 3 – this is FAN 2.*

*Fan Y has Serial Number 1527006PDZ – Controller Assigns Modbus Address 4 – this is FAN 3.*



If more than 5 fans are found, press “>” to go to the next set of 5 fans, and press “<” to return to the previous set.

Press “Retry” to get back to “Find existing fan network” / “Auto address fans” page.

Press “Confirm” to confirm the found array of fans and go to next page (See 4.3.9).

Press “Reorder” to go to the reordering page (see 4.3.8).

### 4.3.8 Re-ordering fans

The automatic assignment of Modbus addresses to fans can be inconvenient for the user as the process assigns an address based on the serial no. of the fan. The user may prefer to alter this and address the fans based on a position of the fans in the array or building for example. For this reason, it is possible to swap fan numbers to match the equipment or building layout.

If Gen3 fans are used, there are two reordering options to choose from: Visual Reordering and Daisy Chain Interface (DCI) Reordering. Select the preferred option.

If Gen2 fans are used, the Visual Reordering option is selected automatically.

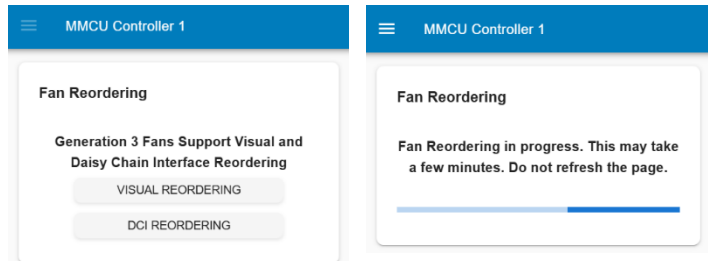

#### 4.3.8.1 Visual Re-ordering

Depending on the generation of the fan, there are two features to help identify which fan is being moved. For Gen3 fans with Modbus version 6.5 or above you can use the LED on the back of the fan to identify which one to move. The default operation for all Gen2 fans is to nudge the fan slightly so you can identify it. Gen3 fan nudging is optional and can be selected by enabling the “Nudge Gen 3 Fans” checkbox.

Starting with fan 1, the controller will identify the fan, and you enter its current position based on your desired layout plan. Choose a new fan location from the “New Fan Location” drop down menu. The fan will stop being nudged or indicated after selection. Use the “>” to move to the next fan, which will start being nudged or indicated.

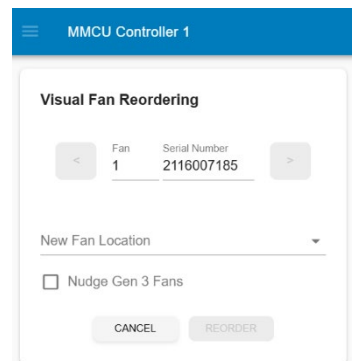

Press “<” to select the previous fan.

MMCUC: epUK p/n CN1127 – epM p/n 8217139626

Press “Cancel” to get back to “Find existing fan network” / “Auto address fans” page.

The “Confirm” button will be disabled until a new order of fans has been entered. All fans must be assigned their order.

The yellow light will turn on and off during re-ordering process.



- Note 1:** This feature is not available when using the controller with only one fan.
- Note 2:** It is not possible to assign a fan number outside the total number of fans e.g. if using the controller with a 4-fan array, the fan numbers will be restricted to 1-4, with the corresponding Modbus addresses 2-5.

### 4.3.8.2 DCI Reordering

Daisy Chain method of re-ordering is useful when visibility for all fans is not possible due to the number of fans or location. An extra connection is required as shown in Figure 3 which needs connecting in the order that the fans are required to be in.

If the reordering process fails, an error message will be shown. Auto addressing option must be selected next to restart the process.

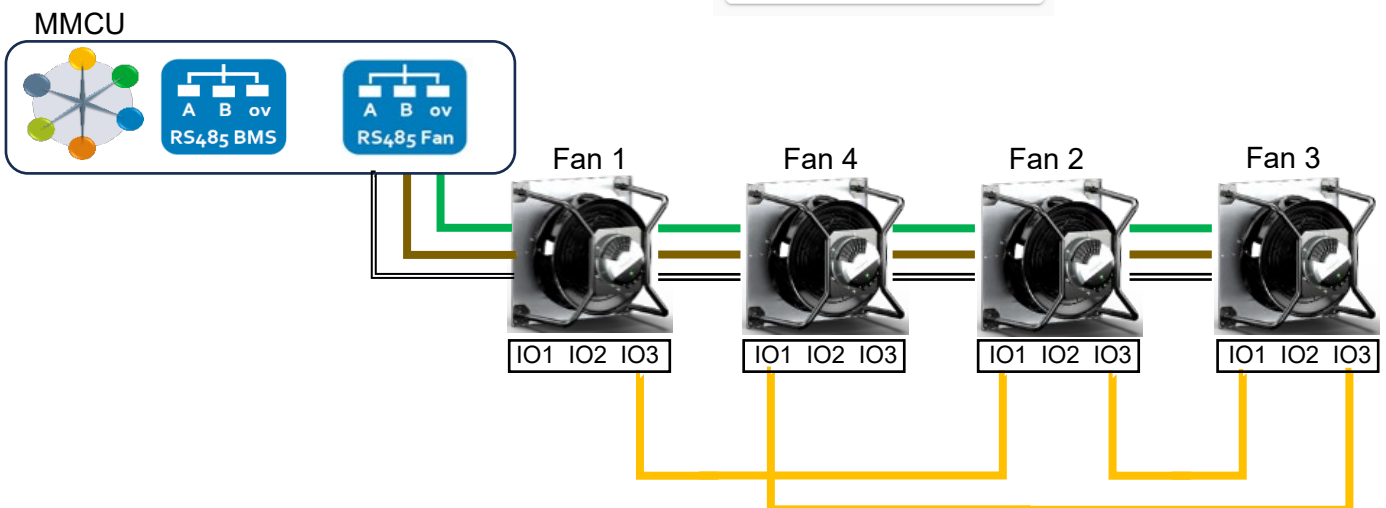
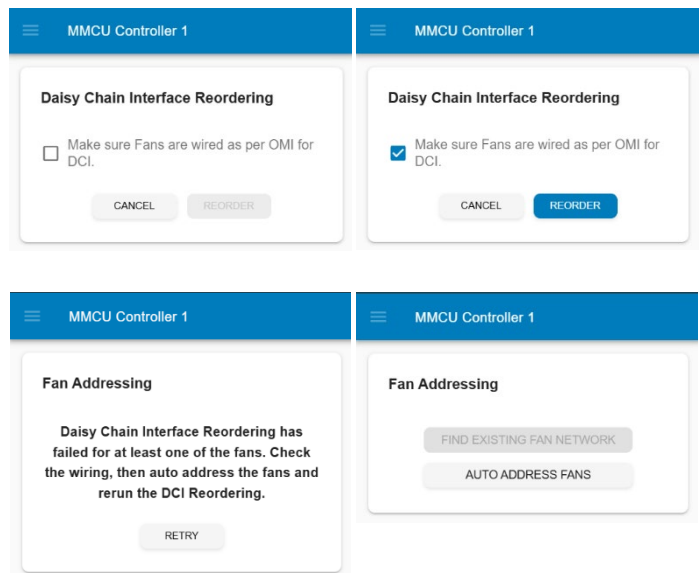

Figure 3 – Daisy chain reordering extra fan connection

### 4.3.9 Fan Grouping

The Fan array can be split into two groups if required for example if a system is split into two separate chambers where the performance of each group may be required to be different. Depending on the Operating mode, different control methodologies for the groups are applied (See Section 5.0).



If more than 5 fans are found, press “>” to go to the next set of 5 fans, and press “<” to return to the previous set.

If only 1 group is required, press “Confirm” to go to the next page.

If two groups are required, check the “Two Fan Groups” checkbox for the screen to update.

The “Confirm” button will be disabled until at least 1 Fan is selected for Group 1.

Any fan that is placed in Group 2 will be nudged (Gen3 if “Nudge Gen 3 fans” options is selected), or the LED set (for Gen3 V6.5 and above).

Press “Confirm” to go to the next page.

MMCU Controller 1

Fan Grouping

Two Fan Groups

Nudge Gen 3 Fans

Fan	Address	Serial Number
1	2	2116007185
2	3	2116007188

CONFIRM

MMCU Controller 1

Fan Grouping

Two Fan Groups

Nudge Gen 3 Fans

Fan	Address	Serial Number	Group
1	2	2116007185	_____ ▾
2	3	2116007188	_____ ▾

CONFIRM

At least 1 Fan must be selected for Group 1!

MMCU Controller 1

Fan Grouping

Two Fan Groups

Nudge Gen 3 Fans

Fan	Address	Serial Number	Group
1	2	2116007185	1 ▾
2	3	2116007188	2 ▾

CONFIRM

## 5.0 Operating modes

### 5.1 Overview



**⚠ Note:** This page can also be reached by pressing “Mode Select” from the side bar.

**⚠ Note:** When any mode is selected, the fans will stop running as they are now being configured. This does not apply to Monitor Mode.

#### Monitor mode:

- Monitors a set of pre-defined fan parameters and displays the information via a Wi-Fi connection to the bespoke configuration Webserver App, or via an Ethernet connection or the ‘RS485 BMS’ port.
- Any fault condition is raised by an on-board LED and a volt-free relay (if configured).
- An optional 0-10V / 4-20mA differential pressure sensor can provide a signal to the controller to display either differential pressure or used to calculate and display volume flow. (See table 6).

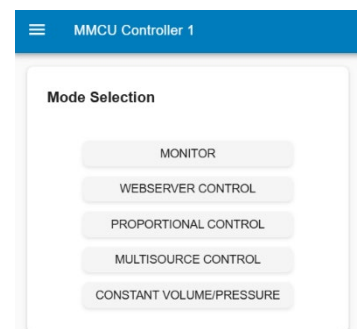

#### Webserver control mode:

- As per monitor mode plus setting a fan speed % from the Webserver App interface.
- An optional 0-10V / 4-20mA differential pressure sensor can provide a signal to the controller to display either differential pressure or used to calculate and display volume flow. (See table 6).

#### Proportional Control mode (open loop):

- As per monitor mode plus setting a fan speed % from one of the controller inputs. (See table 2).
- An optional 0-10V / 4-20mA differential pressure sensor can provide a signal to the controller to display either differential pressure or used to calculate and display volume flow. (See table 6).

#### Multi source:

- As per monitor mode plus setting a fan speed % from either an external ‘RS485 BMS’ connection or from the Webserver App or from the 0-10V inputs to the controller. If multiple sources are connected at once, then whichever changes last will change the fan speed %.
- An optional 0-10V / 4-20mA differential pressure sensor can provide a signal to the controller to display either differential pressure or used to calculate and display volume flow. (See table 6).

#### Constant Volume / Constant Pressure mode (closed loop):

- As per monitor mode plus setting a control setpoint(s) via the Webserver App interface.
- At least one 0-10V / 4-20mA differential pressure sensor is required to provide feedback to the controller for Constant Volume or Constant Pressure. (See table 6).



Operation mode	Fan group	Monitor sensor enabled	Group 2 mode	Monitor sensor options	Control input group 1	Control input group 2
Monitor	1 or 2	No			Fan input directly	
		Controller		0-10V 1		
				0-10 V 2 4-20mA		
Webserver control	1 or 2	No	Offset tracking or Independent		Webserver	
		Controller		0-10V 1		
		Fan		0-10 V 2 4-20mA Ain1, Ain2, IO1, IO2		
Proportional Control	1	No			0-10V 1	
		Controller		0-10V 2		
		Fan		4-20mA Ain1, Ain2, IO1, IO2		
	2	No	Offset Tracking Independent		0-10V 1	0-10V 2
		Controller	Offset Tracking Independent	0-10V 2 4-20mA		0-10V 2
		Fan	Offset Tracking Independent	4-20mA Ain1, Ain2, IO1, IO2		0-10V 2
Constant Volume / Pressure	1	Controller		0-10V 1	Manual Setpoints	
		Fan		0-10 V 2 4-20mA Ain1, Ain2, IO1, IO2		
	2	Controller	Independent	0-10V 1	Manual Setpoints	
		Fan		0-10 V 2 4-20mA Ain1, Ain2, IO1, IO2		
Multi-source	1	No			RS485 BMS or Webserver or 0-10V 1	
		Controller		0-10 V 2		
		Fan		4-20mA Ain1, Ain2, IO1, IO2		
	2	No	Offset Tracking Independent		RS485 BMS or Webserver or 0-10V 1	0-10V 2
		Controller	Offset Tracking Independent	0-10V 2 4-20mA		0-10V 2
		Fan	Offset Tracking Independent	4-20mA Ain1, Ain2, IO1, IO2		0-10V 2

Table 6 - Operation mode options



## 5.2 Monitor mode

Monitor mode can be used to monitor the status of all Modbus fans attached, giving an overview (see table 7 & 8) of critical fan information, alarms, and warnings.

Fan control is handed back to the local fan 0-10v input Ain1U or IO2 depending on the generation of fan.

The enable monitor sensor option allows you to set up a pressure sensor connected to one of the controller inputs. This can be used to display a system pressure or volume flow.

Press “Back” to return to the previous page.

Press “Configure” to go to Sensor configuration page:

(See section 6.1)

Press “Start” to start the selected operation mode.

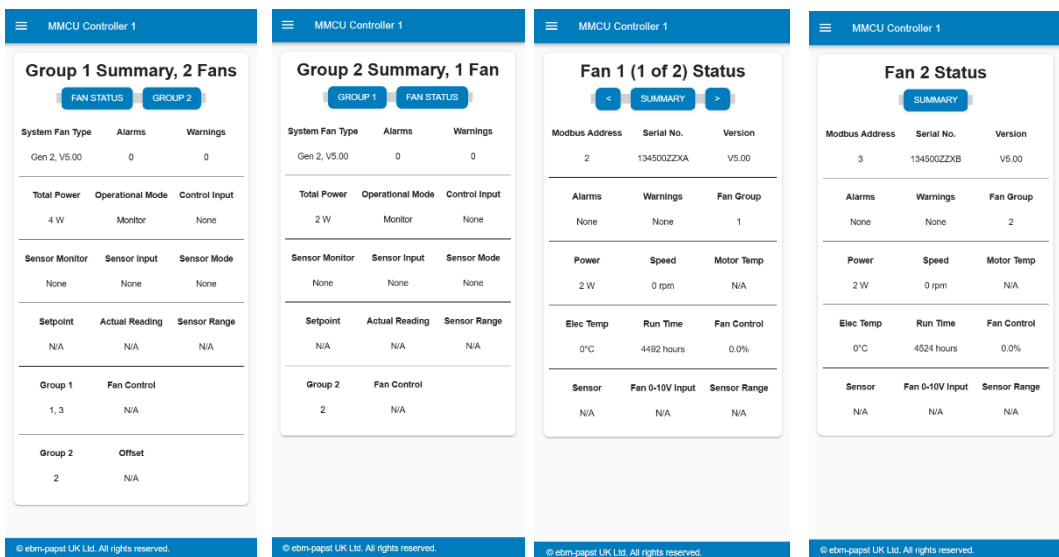
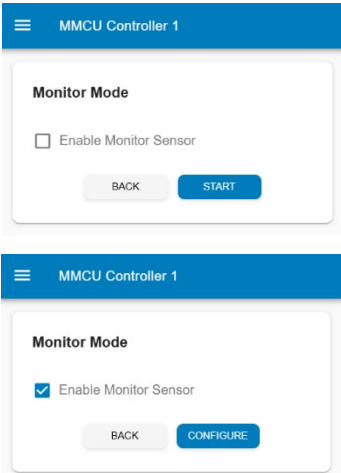

The Summary page will be displayed following activation of the operating mode. You can switch between group summaries or drill into fan status information using the blue buttons at the top of the screen.



### 5.3 Webserver control mode

Webserver control mode is a manual input fixed speed % entered from the Webserver App using your phone, tablet, laptop or HMI. It can be used to speed control a group of fans and monitor the status of all fans attached, giving an overview (see table 7 & 8) of critical fan information, alarms and warnings. This mode can be useful when commissioning a system to understand what performance is required before using another control mode.

If two groups have been setup then a choice of Offset tracking or Independent will be available. This will allow Group2 to follow Group1 in Offset tracking mode or have a completely separate control if used in Independent mode.

The enable monitor sensor option allows you to set up a pressure sensor connected either to one of the controller inputs or to one of the fans in the network. This can be used to display a system pressure or volume flow.

Press “Back” to return to the previous page.

Press “Configure” to go to Sensor configuration page: (See section 6.1)

Press “Start” to start the selected operation mode.

Press “Edit Speed” button to change the ‘Fan Control’ % in the Summary page for a value between 0 – 100%.

Press “Edit Speed & Setpoint” button to change the ‘Fan Control’ % in the Summary page for a value between 0 – 100% for Group 1 and ‘Offset’ % for Group 2 for a value between 0 – 100%.

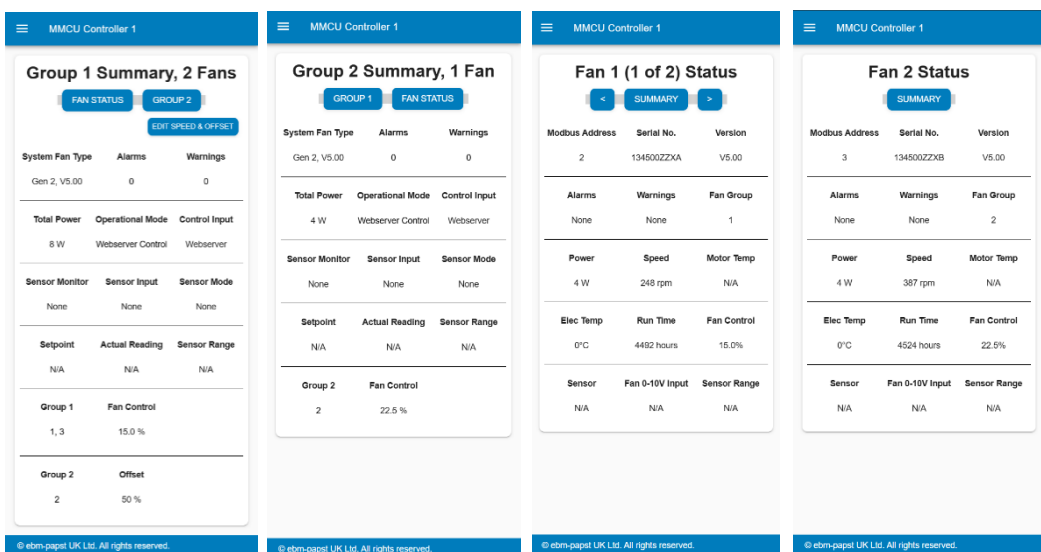
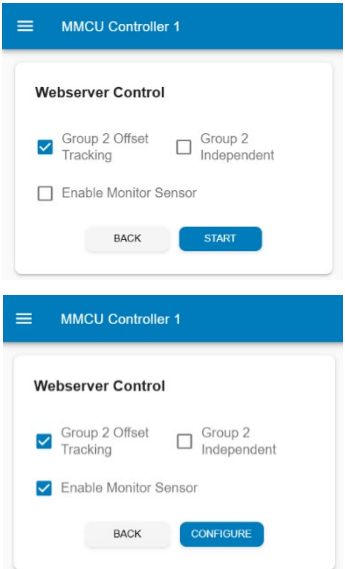

All fans within Group 1 will run at that corresponding speed following a “return” key on the keyboard.

The Group 2 offset can be adjusted in the same way if applicable. A negative value will mean Group 2 will run slower than Group 1 and a positive value will mean Group 2 will run faster than Group 1.



The screenshots show the following data:

- Group 1 Summary, 2 Fans:** System Fan Type: Gen 2, V5.00; Alarms: 0; Warnings: 0; Total Power: 4 W; Operational Mode: Webserver Control; Control Input: Webserver; Sensor Monitor: None; Sensor Input: None; Sensor Mode: None; Setpoint: N/A; Actual Reading: N/A; Sensor Range: N/A; Group 1 Fan Control: 1, 3 at 0.0%; Group 2 Fan Control: 2 at 0.0%.
- Group 2 Summary, 1 Fan:** System Fan Type: Gen 2, V5.00; Alarms: 0; Warnings: 0; Total Power: 2 W; Operational Mode: Webserver Control; Control Input: Webserver; Sensor Monitor: None; Sensor Input: None; Sensor Mode: None; Setpoint: N/A; Actual Reading: N/A; Sensor Range: N/A; Group 2 Fan Control: 2 at 0.0%.
- Fan 1 (1 of 2) Status:** Modbus Address: 2; Serial No.: 134500ZZXA; Version: V5.00; Alarms: None; Warnings: None; Fan Group: 1; Power: 2 W; Speed: 0 rpm; Motor Temp: N/A; Elec Temp: 0°C; Run Time: 4492 hours; Fan Control: 0.0%; Sensor: N/A; Fan 0-10V Input: N/A; Sensor Range: N/A.
- Fan 2 Status:** Modbus Address: 3; Serial No.: 134500ZZXB; Version: V5.00; Alarms: None; Warnings: None; Fan Group: 2; Power: 2 W; Speed: 0 rpm; Motor Temp: N/A; Elec Temp: 0°C; Run Time: 4524 hours; Fan Control: 0.0%; Sensor: N/A; Fan 0-10V Input: N/A; Sensor Range: N/A.

In independent mode, all fans within Group 1 and Group 2 will run at that corresponding speed following a “return” key on the keyboard.

### 5.4 Proportional control mode

Proportional control mode is an open loop control mode accepting an input from an external source to control the speed of a group of fans and monitor the status of all fans attached, giving an overview (see table 7 & 8) of critical fan information, alarms and warnings. (See Appendix A.1)

The enable monitor sensor option allows you to set up a pressure sensor connected either to one of the controller inputs or to one of the fans in the network. This can be used to display a system pressure or volume flow.

Available options for the Control input are: 0-10V 1 for Group 1 and 0-10V 2 if using Group 2 in Independent mode. (see table 6)

If you enable the sensor monitor, the choice of input will depend on the control settings already chosen.

Press “Back” to return to the previous page.

Press “Configure” to go to Sensor configuration page: (See section 6.1)

Press “Start” to start the selected operation mode.

The screenshots show the following settings:

- Proportional Control (Left):** Group 2 Offset Tracking ; Group 2 Independent ; Enable Monitor Sensor ; Both groups are controlled via 0-10 V 1 input; Buttons: BACK, START.
- Proportional Control (Middle):** Group 2 Offset Tracking ; Group 2 Independent ; Enable Monitor Sensor ; Group 1 is controlled via 0-10 V 1 input; Group 2 is controlled via 0-10 V 2 input; Buttons: BACK, START.
- Proportional Control (Right):** Group 2 Offset Tracking ; Group 2 Independent ; Enable Monitor Sensor ; Both groups are controlled via 0-10 V 1 input; Buttons: BACK, CONFIGURE.



MMCUC Controller 1

### Group 1 Summary, 2 Fans

FAN STATUS | GROUP 2 | EDIT OFFSET

System Fan Type	Alarms	Warnings
Gen 2, V5.00	0	0

Total Power	Operational Mode	Control Input
8 W	Proportional Control	0-10 V 1

Sensor Monitor	Sensor Input	Sensor Mode
Controller	0-10 V 2	Total Average

Setpoint	Actual Reading	Sensor Range
N/A	2016 m/h	4807 m/h

Group 1	Fan Control
1, 3	8.7 %

Group 2	Offset
2	50 %

© ebm-papst UK Ltd. All rights reserved.

2 groups in Offset mode with an enabled sensor for Group 1 only via the controller.

MMCUC Controller 1

### Group 1 Summary, 2 Fans

FAN STATUS | GROUP 2

System Fan Type	Alarms	Warnings
Gen 2, V5.00	0	0

Total Power	Operational Mode	Control Input
4 W	Proportional Control	0-10 V 1

Sensor Monitor	Sensor Input	Sensor Mode
None	None	None

Setpoint	Actual Reading	Sensor Range
N/A	N/A	N/A

Group 1	Fan Control
1, 3	8.8 %

Group 2	Fan Control
2	17.6 %

© ebm-papst UK Ltd. All rights reserved.

2 groups in Independent mode without a sensor monitor enabled.

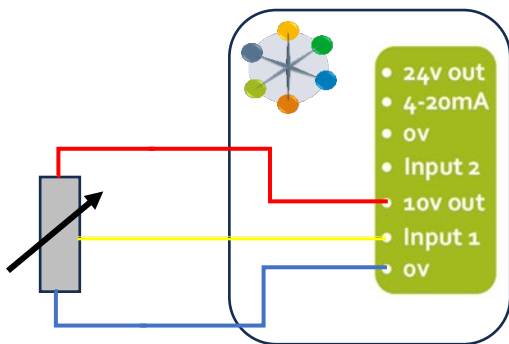

Figure 4 - Example 0-10v potentiometer input



### 5.5 Constant Volume / Pressure mode

Constant Volume / Pressure mode is a closed loop control which requires at least one pressure sensor connected to the system. (See Section 6.0) for how to select the correct sensor range and arrange one or more sensors depending on the required mode of operation. (See Appendix A.2) for how the control strategy works. (See Section 6.1) for how to configure a sensor.

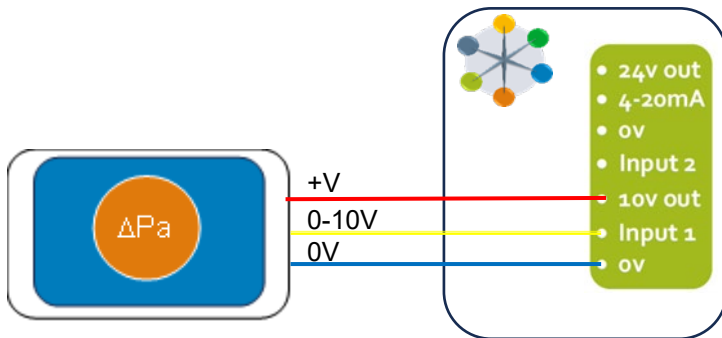

Figure 5 – Example pressure sensor connection to controller

After setting up the sensor / sensors and pressing “Confirm” you can then set a target Setpoint or Setpoints. A single setpoint is the default. The units to be used are defined by the operation mode (Volume or Pressure) and whether you are using metric or imperial units.

Dual setpoint option is available which is toggled using Switch input 2 as shown in Figure 6. To alter the orientation of the input (See Section 7.7).

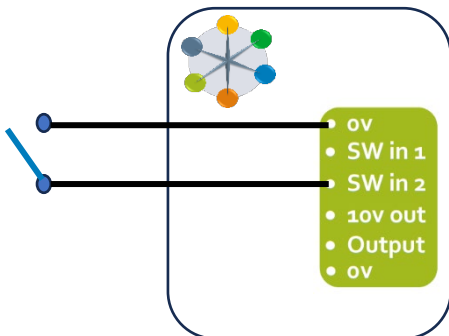
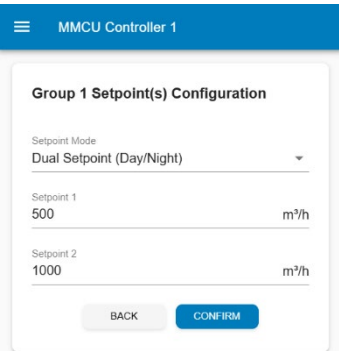
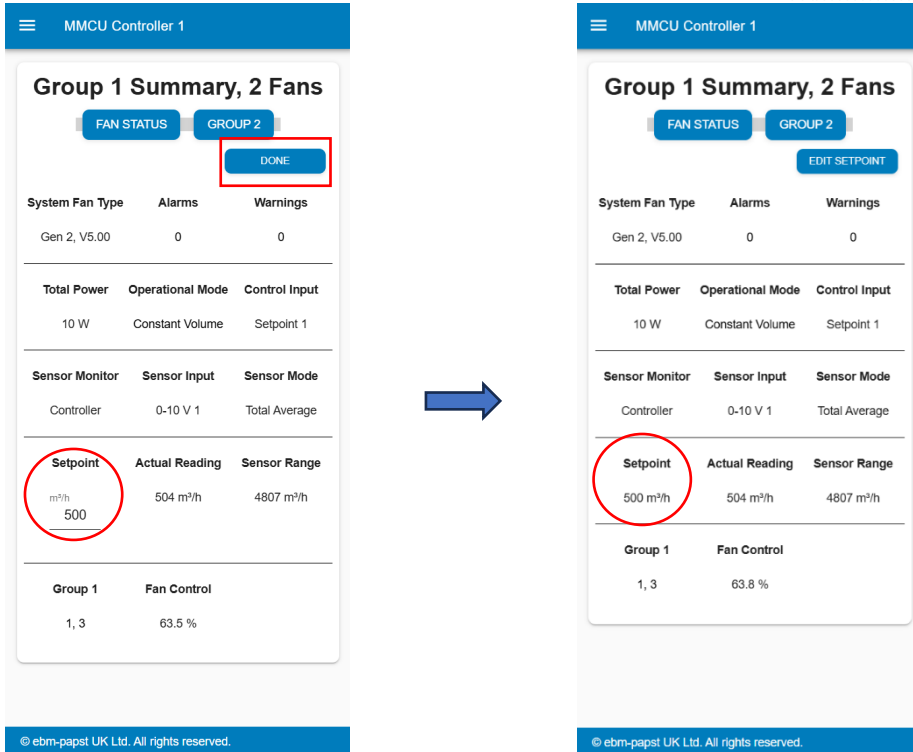

Figure 6 - Switch between two setpoints





If the setpoint needs to be updated, press the “Edit Setpoint” button in the Group Summary page, enter the new value, press “return” key on the keyboard or press “Done”.



## 5.6 Multi source control mode

Multi source control mode can be used to speed control a group of fans and monitor the status of all fans attached, giving an overview (see table 7 & 8) of critical fan information, alarms and warnings.

The enable monitor sensor option allows you to set up a pressure sensor connected either to one of the controller inputs or to one of the fans in the network. This can be used to display a system pressure or volume flow.

This option allows group control from either Webserver, Proportional control (0-10V 1 / 0-10V 2) or from an external Modbus connection (BMS) (Fan Array Speed Register – see Appendix B.2, Table 11).

Press “Back” to return to the previous page.

Press “Configure” to go to Sensor configuration page: (See section 6.1)

Press “Start” to start the selected operation mode.

The last value to change will update the speed.

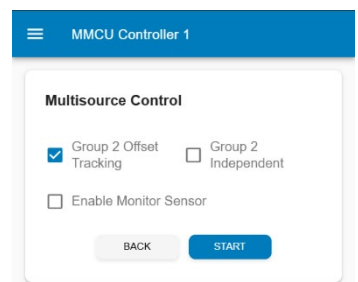

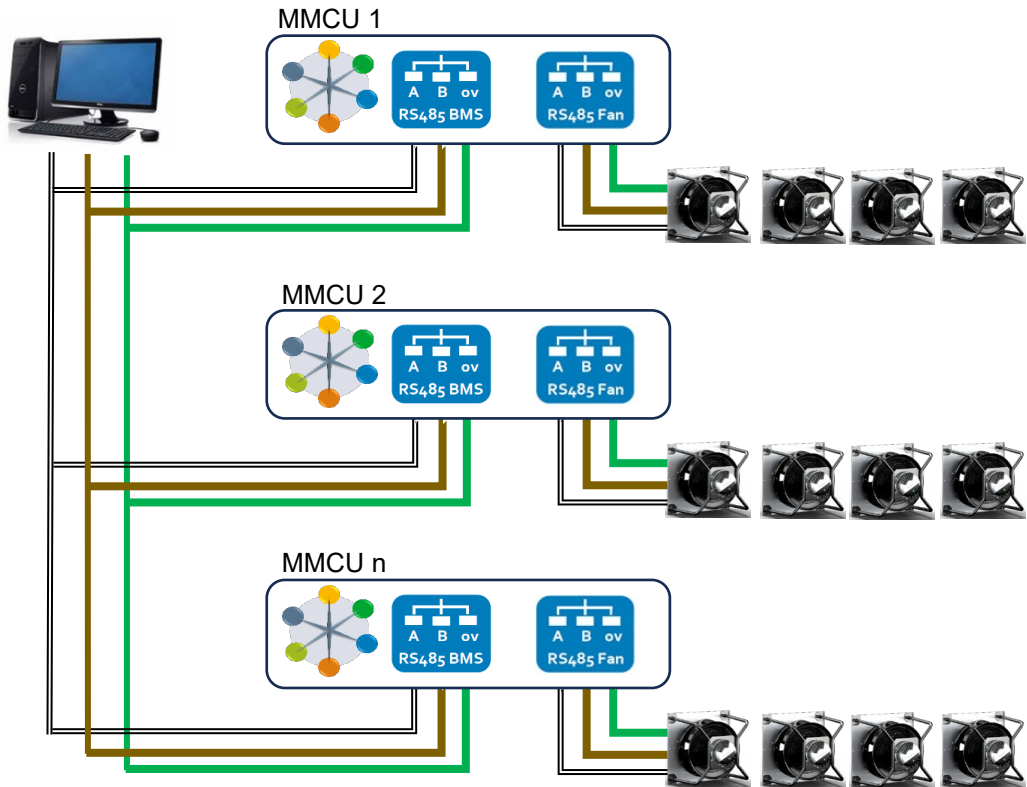

Figure 7 - Example BMS connection



2 groups in Offset Tracking mode without a sensor monitor enabled

MMCUC Controller 1

### Group 1 Summary, 2 Fans

FAN STATUS | GROUP 2 | EDIT SPEED & OFFSET

System Fan Type	Alarms	Warnings
Gen 2, V5.00	0	0

Total Power	Operational Mode	Control Input
8 W	Multisource Control	Multisource

Sensor Monitor	Sensor Input	Sensor Mode
None	None	None

Setpoint	Actual Reading	Sensor Range
N/A	N/A	N/A

Group 1	Fan Control
1, 3	20.0 %

Group 2	Offset
2	50 %

MMCUC Controller 1

### Group 2 Summary, 1 Fan

GROUP 1 | FAN STATUS

System Fan Type	Alarms	Warnings
Gen 2, V5.00	0	0

Total Power	Operational Mode	Control Input
5 W	Multisource Control	Multisource

Sensor Monitor	Sensor Input	Sensor Mode
None	None	None

Setpoint	Actual Reading	Sensor Range
N/A	N/A	N/A

Group 2	Fan Control
2	30.0 %

MMCUC Controller 1

### Fan 1 (1 of 2) Status

SUMMARY

Modbus Address	Serial No.	Version
2	134500ZZXA	V5.00

Alarms	Warnings	Fan Group
None	None	1

Power	Speed	Motor Temp
4 W	338 rpm	N/A

Elec Temp	Run Time	Fan Control
0°C	4482 hours	20.0%

Sensor	Fan 0-10V Input	Sensor Range
N/A	N/A	N/A

MMCUC Controller 1

### Fan 2 Status

SUMMARY

Modbus Address	Serial No.	Version
3	134500ZZXB	V5.00

Alarms	Warnings	Fan Group
None	None	2

Power	Speed	Motor Temp
5 W	540 rpm	N/A

Elec Temp	Run Time	Fan Control
0°C	4524 hours	30.0%

Sensor	Fan 0-10V Input	Sensor Range
N/A	N/A	N/A

2 groups in Independent mode without a sensor monitor enabled

MMCUC Controller 1

### Group 1 Summary, 2 Fans

FAN STATUS | GROUP 2 | EDIT SPEED

System Fan Type	Alarms	Warnings
Gen 2, V5.00	0	0

Total Power	Operational Mode	Control Input
8 W	Multisource Control	Multisource

Sensor Monitor	Sensor Input	Sensor Mode
None	None	None

Setpoint	Actual Reading	Sensor Range
N/A	N/A	N/A

Group 1	Fan Control
1, 3	10.0 %

Group 2	Fan Control
2	17.6 %

MMCUC Controller 1

### Group 2 Summary, 1 Fan

GROUP 1 | FAN STATUS | EDIT SPEED

System Fan Type	Alarms	Warnings
Gen 2, V5.00	0	0

Total Power	Operational Mode	Control Input
4 W	Multisource Control	Multisource

Sensor Monitor	Sensor Input	Sensor Mode
None	None	None

Setpoint	Actual Reading	Sensor Range
N/A	N/A	N/A

Group 2	Fan Control
2	17.6 %

MMCUC Controller 1

### Fan 1 (1 of 2) Status

SUMMARY

Modbus Address	Serial No.	Version
2	134500ZZXA	V5.00

Alarms	Warnings	Fan Group
None	None	1

Power	Speed	Motor Temp
4 W	176 rpm	N/A

Elec Temp	Run Time	Fan Control
0°C	4482 hours	10.0%

Sensor	Fan 0-10V Input	Sensor Range
N/A	N/A	N/A

MMCUC Controller 1

### Fan 2 Status

SUMMARY

Modbus Address	Serial No.	Version
3	134500ZZXB	V5.00

Alarms	Warnings	Fan Group
None	None	2

Power	Speed	Motor Temp
4 W	301 rpm	N/A

Elec Temp	Run Time	Fan Control
0°C	4524 hours	17.6%

Sensor	Fan 0-10V Input	Sensor Range
N/A	N/A	N/A



## 5.7 Group 2 offset / Independent

The Group 2 offset is available for Webserver, Proportional and Multi source control modes. It offers a  $\pm$  % tracking of the Group 1 speed settings either with less or more performance. For example, in Webserver mode, if Group 1 is set to 50% speed and Group 2 offset is set to +50% then Group 2 will run at 75%. Alternatively, if the offset is set to -50%, Group 2 will run at 25%. If any minimum or maximum caps have been applied from the advanced menu (see section 7.4), then these limits will apply to all fans. A minimum offset of -99% can be applied which essentially will run Group 2 at minimum speed or off.

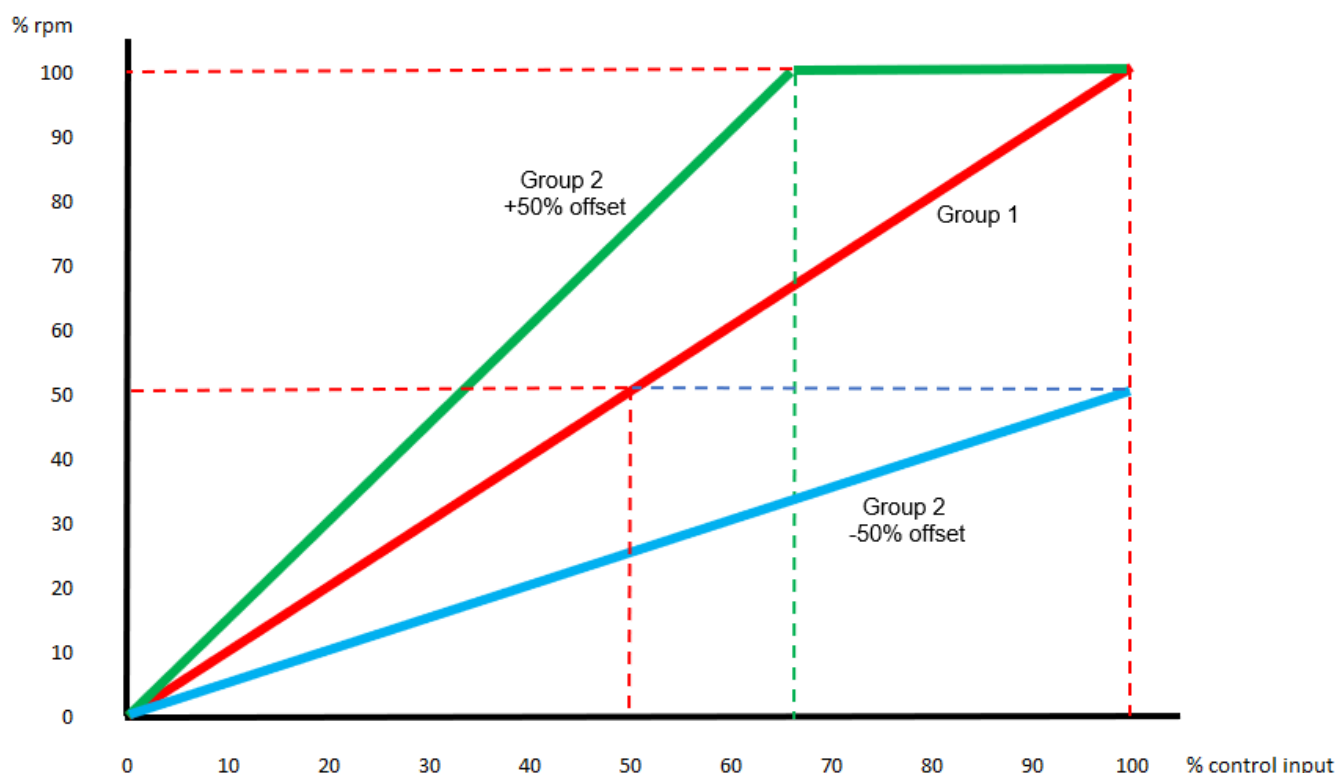

Figure 8 – Offset example for Group 2

To change the offset value, press “Edit Speed & Offset” or “Edit Offset” button. Displayed button text depends on selected mode. Enter the required offset value then press “Enter” to confirm. The speed of Group 2 will be adjusted accordingly.

If Independent mode is selected for 2 groups this will allow two separate inputs to be utilised on the controller when in Proportional mode, each acting independently for the two groups of fans. In Webserver mode then two separate manual inputs apply and in Multi source the additional ability from the BMS to set two values is available.



## 5.8 Summary Page

The Summary page exists for up to 2 groups. The layout is the same for each operational mode but with more or less information provided.

Heading	Description
System Fan Type	Motor generation and Modbus protocol version for group of fans.
Alarms	Any active Alarm from the group of fans or controller (Red LED).
Warnings	Any active Warning from the group of fans or controller (Amber LED).
Total Power	Total Power consumption (Watts) for all fans in the connected group.
Operational Mode	Current operational mode.
Control Input	Source of the control input for open loop or setpoint for closed loop, for all fans in the connected group. (not Monitor mode).
Sensor Monitor	Source for connected sensor (fan or controller).
Sensor Input	Input connection for sensor.
Sensor Mode	Combining multiple sensors can be Average, Min, Max or Sum (Depends on Operation Mode).
Setpoint	Actual target value for Constant Volume / Pressure (Closed loop).
Actual Reading	Actual reading from connected sensor or sensors.
Sensor Range	Full scale sensor range. Air volume or Air pressure.
Group	Indicates which fans are in which group.
Fan Control	Control %
Controller Warnings	Controller detected warnings. This section is disabled when no controller warnings are detected.

Table 7 - Group summary headings

### Group 1 Summary, 2 Fans

FAN STATUS
GROUP 2

System Fan Type	Alarms	Warnings
Gen 2, V5.00	0	0

---

Total Power	Operational Mode	Control Input
4 W	Monitor	None

---

Sensor Monitor	Sensor Input	Sensor Mode
None	None	None

---

Setpoint	Actual Reading	Sensor Range
N/A	N/A	N/A

---

Group 1	Fan Control
1, 3	N/A

---

Group 2	Fan Control
2	N/A



## 5.9 Fan Status Page

From the ‘Group Summary’ screen, press “Fan Status” to go to the Fan Status page. Fans of the same group are displayed on this page. To see the information of the fans from a different group, go back to the ‘Group Summary’ screen, select the other group, and press “Fan Status” button.

Heading	Description
Modbus Address	Fan Modbus Address starting at 2 (Fan 1).
Serial No.	Individual Fan serial no. (also shown on label).
Version	Modbus protocol version for fan.
Alarms	Individual Alarm notification (Red LED).
Warnings	Individual Warning notification (Amber LED).
Fan Group	Which group the fan belongs to.
Power	Individual Actual Power (Watts).
Speed	Individual Actual Speed (rpm).
Motor Temp	Motor temperature (°C) if available. (Depends on Version). *1
Elec Temp	Electronics temperature (°C).
Run Time	Individual run time total (hours).
Fan Control	% control level being sent to individual fan.
Sensor	Direct or Indirect connected sensor at the fan. Measured value shown depending on Operational mode. Air volume (m3/h or cfm) or Air pressure (Pa or in.w.g). *2
Fan 0-10V Input	Input value (volts) at the fan input.
Sensor Range	Full scale sensor range. Air volume or Air pressure.
Harmonic Velocity X	Harmonic Vibration Velocity X (mm/s) *3
Harmonic Velocity Y	Harmonic Vibration Velocity Y (mm/s) *3
Harmonic Velocity Z	Harmonic Vibration Velocity Z (mm/s) *3
RMS Velocity X	RMS Vibration Velocity X (mm/s) *3
RMS Velocity Y	RMS Vibration Velocity Y (mm/s) *3
RMS Velocity Z	RMS Vibration Velocity Z (mm/s) *3

Table 8 - Fan status headings

- ⚠ Note \*1** - The controller is compatible with all firmware versions of ebmpapst enabled Modbus EC fans version 5.0 and later, however, on ‘Modbus LITE’ reduced functionality fans, some parameters are not available.
- ⚠ Note \*2** - Volume and pressure measurements require one or more external differential pressure sensors per fan group with a 0-10V or 4-20mA output.
- ⚠ Note \*3** - Vibration Velocity Information is supported by the fans that have vibration sensors enabled.

Fan 1 (1 of 2) Status		
< SUMMARY >		
Modbus Address	Serial No.	Version
2	134500ZZXA	V5.00
Alarms	Warnings	Fan Group
None	None	1
Power	Speed	Motor Temp
2 W	0 rpm	N/A
Elec Temp	Run Time	Fan Control
0°C	4492 hours	0.0%
Sensor	Fan 0-10V Input	Sensor Range
N/A	N/A	N/A

Fan 1 (1 of 2) Status		
< SUMMARY >		
Modbus Address	Serial No.	Version
2	2116007185	V6.5
Alarms	Warnings	Fan Group
None	None	1
Power	Speed	Motor Temp
2 W	0 rpm	42°C
Elec Temp	Run Time	Fan Control
40°C	3074 hours	0.0%
Sensor	Fan 0-10V Input	Sensor Range
N/A	N/A	N/A
Harmonic Velocity		
X	Y	Z
0.1 mm/s	0.0 mm/s	0.1 mm/s
RMS Velocity		
X	Y	Z
1.5 mm/s	0.8 mm/s	0.6 mm/s



## 6.0 Pressure sensor connections

For a constant volume, or a volume monitoring system the differential pressure sensor must measure the pressure difference between the fan inlet ring tapping's and the fan air supply side. This is different for a constant pressure, or a pressure monitoring system where the inlet ring is not required, and the sensor must measure the pressure difference between the fan air supply and the fan exhaust. Figure 7 shows exactly where to connect the differential pressure sensor positive and negative tapping's.

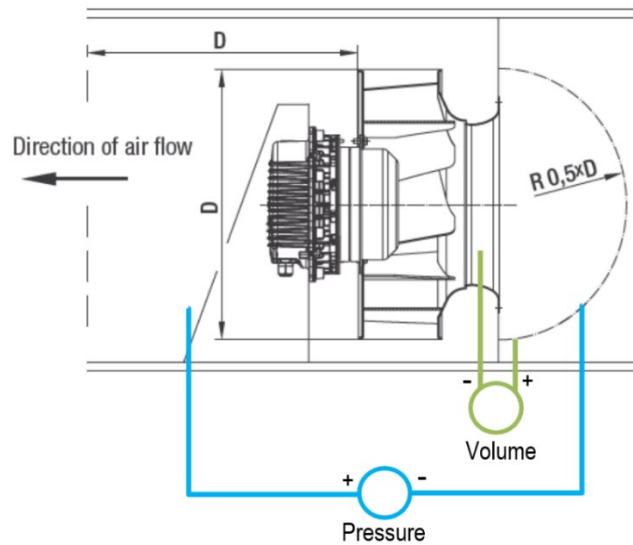

Figure 9 - Pressure sensor connections.

When using inlet rings, due to potential disturbances it is recommended to use a multi-tapped inlet ring which provides an averaged pressure value over all taps to improve the precision of the air volume measurement. If this system operates with a single sensor, the precision of the air volume measurement can be improved further by ensuring that all inlet ring tapping's are equidistant from the sensor as shown in Figure 8.

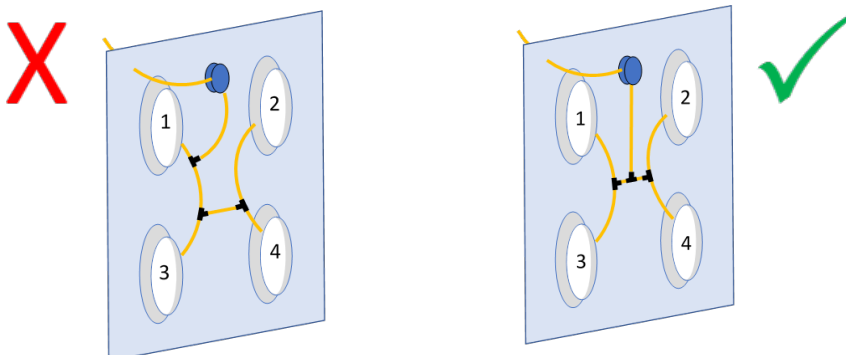

Figure 10 - Connecting to tapping rings for Volume measurement.



## 6.1 Sensor configuration

Configuring a sensor for monitoring or using as control feedback in Constant Volume / Pressure mode requires at least one pressure sensor connected to the system. (See Section 6.0, 6.2, 6.3, 6.4) for how to select the correct sensor range and arrange one or more sensors depending on the required mode of operation.

Initially the Sensor input is selected to be either from the fan or controller. (See Table 6) for Sensor input options depending on your operating mode. It may be beneficial to have more than one sensor connected locally to the fan inputs which can reduce cabling and increase redundancy in case a sensor fails.

The pressure sensor range needs to be selected with a choice of a range from 50Pa to 3500Pa based on the SN1120 / SN1121 range of devices from ebmpapst. If an alternative sensor with a different range is used, the pressure value can be manually entered.

The choice of Volume or Pressure will require different information to be provided.

For Pressure, the sensor reading “average, min or max” can be selected.

For Volume, the k-factor of the impeller is required which can be found in the fan datasheet. The sensor reading will be fixed on “Average”.

If the fan is chosen to be the sensor input, then there is a requirement to Map the sensors.

For mapping sensors please see Section 6.4.

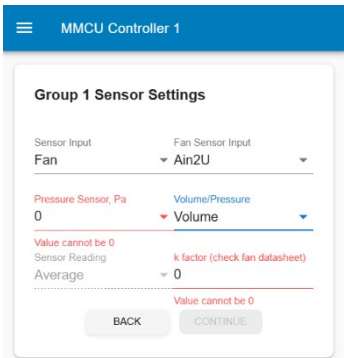
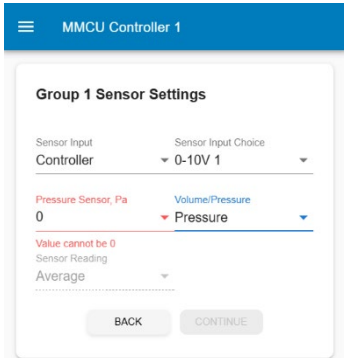

## 6.2 Sensor wiring and airline connections

We recommend using ebm-papst SN1120 or SN1121 series differential pressure sensors as they have been specifically designed for fan arrays and can be powered from a fan’s 10V 10mA, or 24V supply. It simplifies the installation and can greatly reduce commissioning time, cost and complexity of the installation by eliminating the external power supply, sensor zero adjustment and specific mounting positions as they can be mounted at any given orientation without compromising their accuracy.

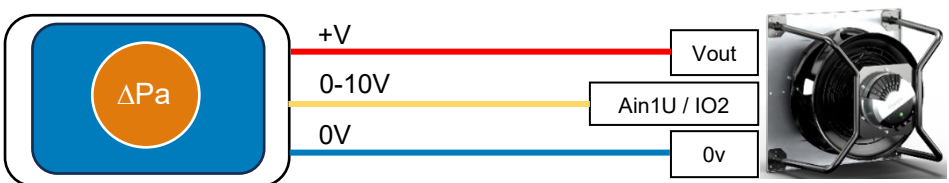

Figure 11 - Example connection of pressure sensor connected to a fan Vout supply.

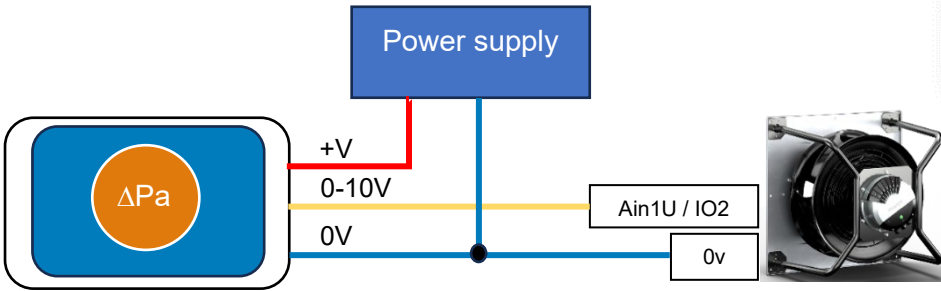

Figure 12 – Example connection of pressure sensor connected to a separate power supply.

- Note:** Do not connect more than one sensor per fan.
- Note:** Please ensure that the selected fan 0-10V input terminal where the sensor output is connected to is the same as the configured fan sensor input on the controller.

**Airline connections (constant volume / volume monitoring):** Care must be taken to keep the connections equidistant from the sensor. An example of “4 fans 2 sensors” system is shown below:

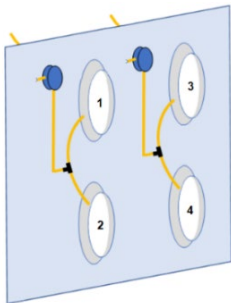

Figure 13 - Installation of multiple pressure sensors for Volume measurement

**Airline connections (constant pressure / pressure monitoring):** Inlet rings are not required for constant pressure or pressure monitoring systems, and therefore one of the airlines can be placed anywhere in front of the fans and the other is placed anywhere behind the fans. An example of a “4 fan 2-sensor” constant pressure system or pressure monitoring system is shown below.

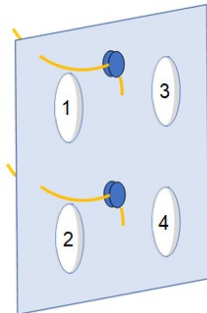

Figure 14 - installation of multiple pressure sensors for Pressure measurement

- Note:** All sensors must have the same pressure range



### 6.3 Choosing the pressure sensor range for constant volume

For volume measurement the choice of sensor range is not related to the pressure drop across the fan but the pressure drop across the inlet ring. To calculate the required pressure, use the following equation.

$$\Delta p = \frac{qV^2}{k^2}$$

$\Delta p$  = Differential pressure (Pa)

$qV$  = Required volume (m<sup>3</sup>/h)

$k$  = factor for each impeller size and inlet ring (shown in datasheet)

#### Example

Fan requirement is 5000m<sup>3</sup>/h @ 150Pa per fan.

K factor for the impeller is 232.

$$\Delta p = \frac{5000^2}{232^2}$$

$$\Delta p = 464 Pa$$

#### Selection

- SN1120-A50      0..50Pa
- SN1120-A200    0..200Pa
- SN1120-A500    0..500Pa
- SN1121-A1000   0..1000Pa
- SN1121-A2000   0..2000Pa
- SN1121-A3500   0..3500Pa

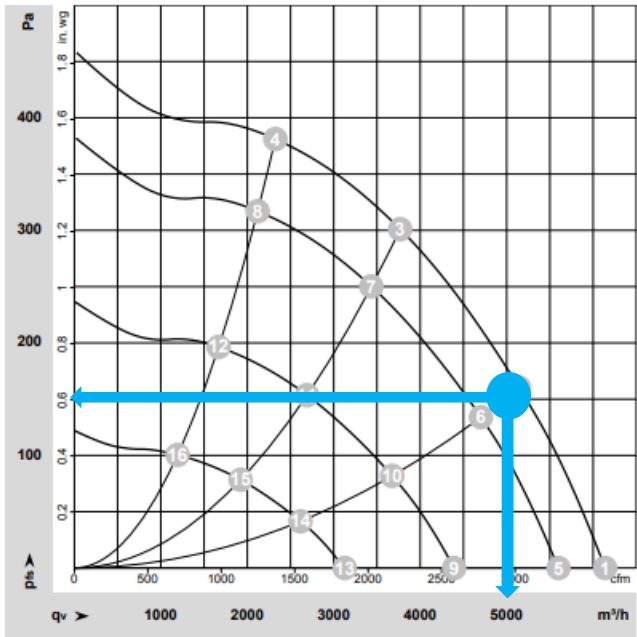

Inlet ring 8217102239 with pressure tap (k-factor: 232)

The target pressure should ideally be close to the middle of the sensor range to ensure the best control capability.



### 6.4 Sensor mapping

Instead of using a single differential pressure sensor, it is possible to connect multiple differential pressure sensors to the system by using the 0-10V inputs of the fans. The operation with multiple differential pressure sensors can improve reading accuracy and introduce another fail-safe layer to the system operation as the controller automatically adjusts the settings in the event of a sensor failure.

Sensor mapping page will be shown after “Continue” button is pressed in Sensor Settings page when “Fan” is selected as a sensor input.

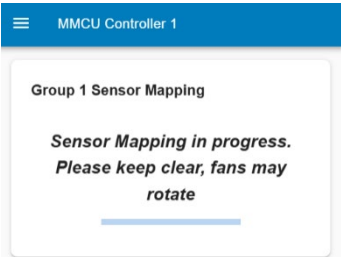

In order to find the sensors and which fan they are attached to, the fans will rotate and therefore a warning will be shown.

- ⚠ Important:** Ensure the area around the fans is clear and personal access is prevented before acknowledging the “Map Sensors” as the controller will immediately run all fans at a potentially high speed.
- ⚠ Note 1:** Multi-sensor operation is not an option during “Monitor” operating mode. In that case, the “Sensor Input” will be defaulted to “Controller” and the controller will look for a differential pressure signal at its own 0-10V or 4-20mA input terminals instead.
- ⚠ Note 2:** It is possible to delete a previously stored map by selecting the “Erase Map” option.

After the controller has finished the mapping, the screen will show which fans have a sensor attached electrically and which, if any, are sharing an air hose from a sensor. The ‘Confirm’ button will then accept the found sensor map.

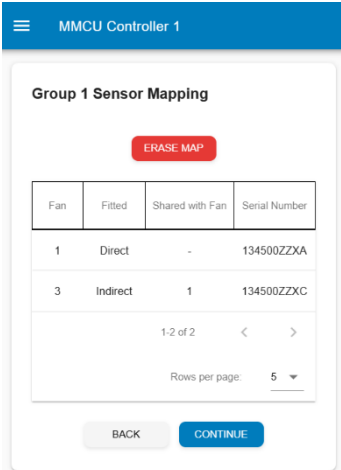
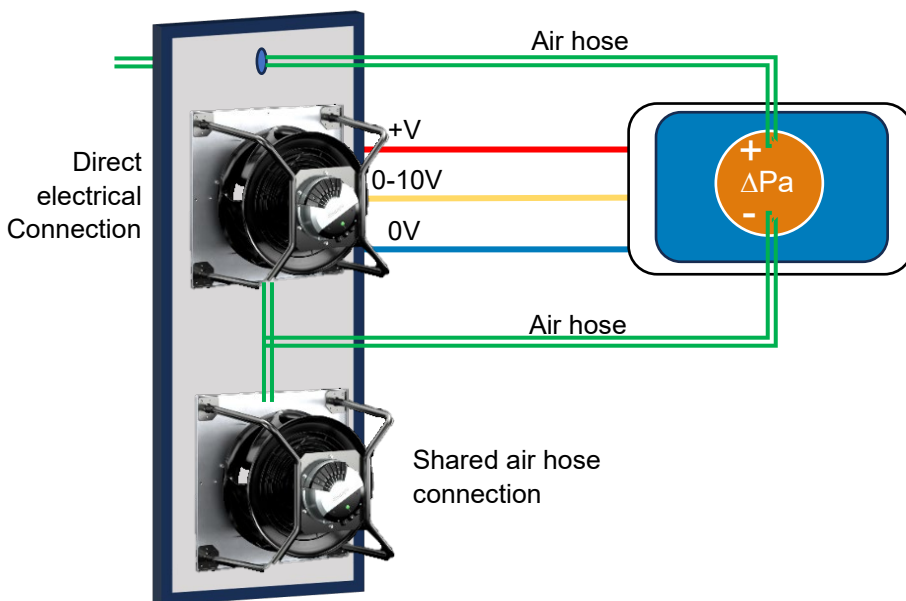

Figure 15 - Volume measurement set up with multiple fans connected to one sensor.



## 7.0 Advanced settings

**Note:** When entering this page, the fans will stop running. This does not apply to Monitor Mode.

### 7.1 Communication Settings for Fans

Displays current settings stored in the controller. Update and press “Set” to confirm and save changes. (see Table 4)

### 7.2 Communication Settings for BMS

Displays the current settings stored in the controller. The recommended controller response time to Modbus master requests is 1 second.

Set the BMS password for extra security. The entered value will be stored in the controller’s non-volatile memory. The BMS Password Register value (refer to Appendix B.2, Table 11) must match to the BMS password value configured via the webserver before you can change any register value via the BMS. If this feature is not required, leave as 0.

Modbus RTU: Update and press “Set” to confirm and save changes. (see Table 5)

Modbus TCP: Update and press “Set” to confirm and save changes.

If selected, using webserver via the ethernet connection cannot be used.

To disable Modbus TCP, connect to the MMCU via Wi-Fi, select and set Modbus RTU or clear BMS configuration Register (refer to Appendix B.2, Table 11).

**Note:** Enabling / disabling Modbus TCP requires MMCU restart.



### 7.3 System Reset & Reboot

“Reboot Controller” option reboots the controller.

“Reset Controller and Fans” option resets the controller and fans to factory settings. The controller will restart and return to the beginning of “Powering up for the first time”. Fan array will have to be auto addressed.

“Reset Controller” option resets the controller to factory default settings. The controller will restart and return to the beginning of “Powering up for the first time”.

“Reset Fans” option resets the fans to factory settings.

Selecting any option brings up a warning dialog box, requiring confirmation before proceeding.

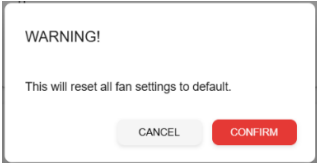
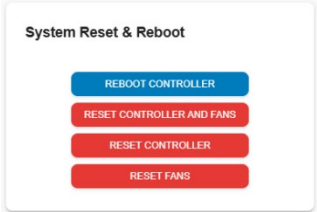

### 7.4 Fan Speed Cap (0-100%)

The fan speed cap is used to restrict the minimum or maximum speed the fans can run at. The Minimum cap can be used to stop the fans from switching off (not available in Constant Volume / Pressure modes). The maximum cap can be used in all modes, for example if there are noise restrictions in the application.

Enter 0-50% value for minimum speed cap, and min-100% value for maximum speed cap. Press “Set” to confirm.

Check “Release Cap on Fan Failure” to enable cap release when one fan fails.

Check “Run at lower limit” to make the fans always run at minimum cap speed.

Check “Switch off” to make the fans switch off below cap speed.

“Run at lower limit” and “Switch off” checkboxes are mutually exclusive.

(See Appendix A.1)

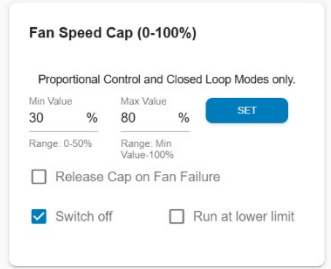
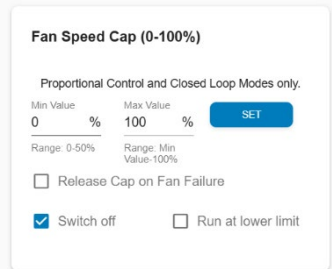



## 7.5 Controller Input Cap (0-100%)

The controller input cap can restrict the range of the input if connected to a sensor for example only in Proportional (open loop) control mode. A hysteresis is used to ensure the system doesn't oscillate on/off at a threshold point.

Enter 0-50% value for minimum input cap, and min-100% value for maximum input cap. Press "Set" to confirm.

If hysteresis is required, make sure that both input and speed min are not 0:

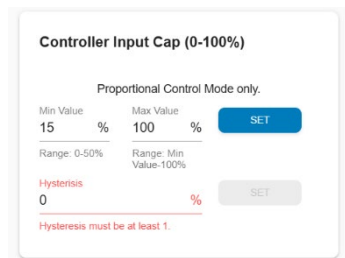
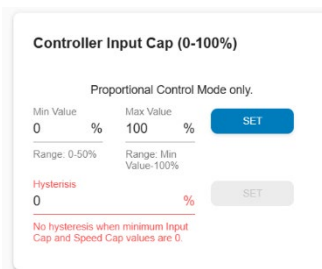

Hysteresis value must be at least 1, otherwise the "set" button is disabled:  
(See Appendix A.1)

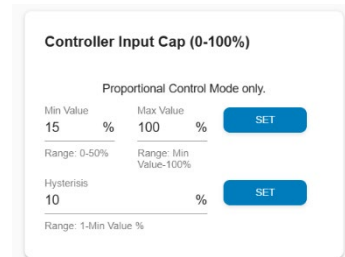

## 7.6 External Switch Input 1 Enable / Disable Fans

Switch Input 1, which is used to enable/disable fans.

By default, when the input is open/high, fans are enabled, when the input is close/low, the fans are disabled.

Current state displays the current input state.

Click on the dropdown box to update the input polarity:

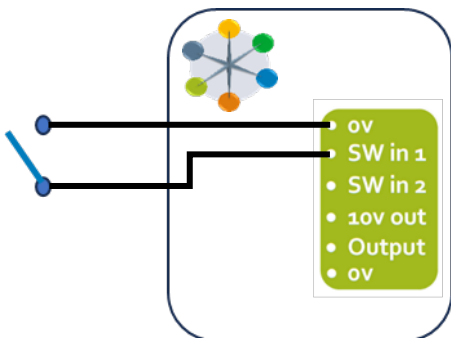
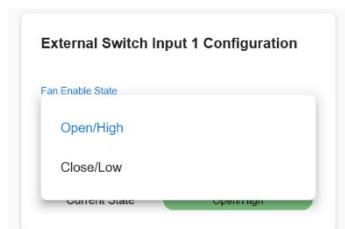
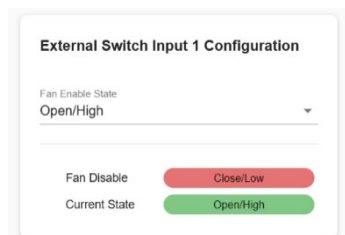

Figure 16 - Enable / Disable switch



## 7.7 External Switch Input 2 Setpoint 1 / Setpoint 2

Switch Input 2 is used to toggle between setpoints when in Constant Pressure or Volume mode.

By default, when the input is open/high, setpoint 1 is active, when the input is close/low, setpoint 2 is active.

Current state displays the current input state.

Click on the dropdown box to update the input polarity:

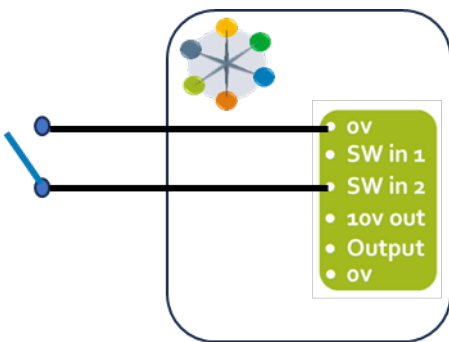
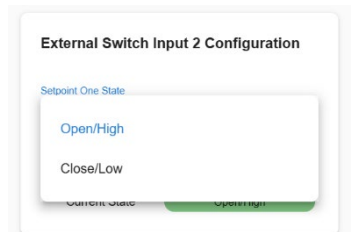
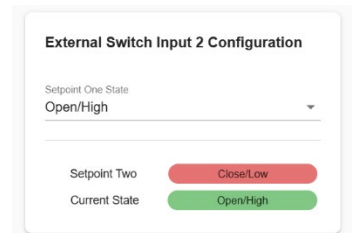

Figure 17 - Setpoint toggle switch



## 7.8 PID values

The default settings are designed to give a reasonable response from a wide range of impeller types, however in some applications it may be required to have a slower or faster response to changes of input.

Default values are P = 100, I = 100, D = 100

Update the values and press set:

Press “reset to default” to reset to original settings.

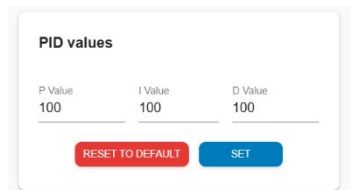



## 7.9 0-10V Output Follower

This output can be used to track one of the groups of fans and control an external device such as a damper.

By default, Group 1 is selected to follow. If there is no Group 2 the selection is disabled.

If both groups are present, then the user can check the required group to follow. The checkboxes are mutually exclusive.

For example, if Group 2 is selected and its fans are running at 46%, 4.6V can be measured at this output if the range is set to 100%.

The output follower range can be adjusted so if set to 50% then the output follower will reach 5V for a 100% fan speed instead of 10V. The output follower response is a linear response to fan speed.

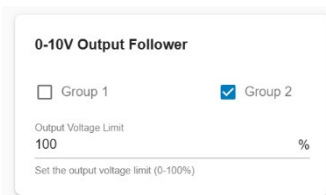
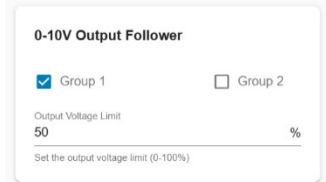

## 7.10 System Units

Options are metric: Pa and m3/h or Imperial: in.w.g and cfm.

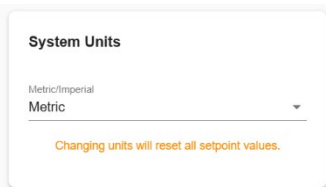

**⚠ Note:** Changing units will reset setpoint, so they will need to be entered again.

## 7.11 Relay Configuration

Default condition is Disabled. Selecting any of the options will configure the relay to trigger when the corresponding event has been detected.

The 2 mutually exclusive checkboxes configure the PCB relay.

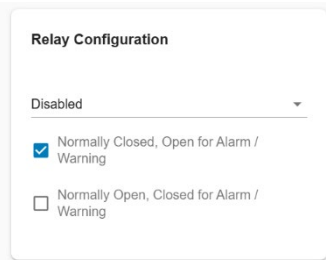
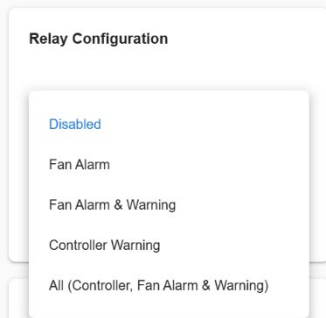



## 7.12 Controller Detected Warnings

Controller detected warnings are disabled by default. Check the box to enable the required warning(s). When enabled and detected, the warning(s) will be displayed on live status page.

### Setpoint Warning

If the fans are running at maximum speed (or capped speed) in Constant Pressure / Volume mode and the setpoint has not been achieved, a warning will be set.

### Sensor Failure Warning

When “Sensor Failure” is checked, the following options become available:

A Sensor failure warning can be configured for a sensor which is being monitored in one of the operating modes. The condition looks at a fan speed % threshold and whether the sensor is achieving a minimum % response. For example, when a fan is running above 25%, the expected response would be to measure at least 10% of the pressure sensor’s range, i.e. for 500Pa sensor 50Pa is expected to be measured at 25%. If this condition is not met a warning will be set.

Controller Detected Warnings

**Setpoint Warning**

Setpoint Not Achievable

**Sensor Failure Warning**

Sensor Failure

Controller Detected Warnings

**Setpoint Warning**

Setpoint Not Achievable

**Sensor Failure Warning**

Sensor Failure

Min Speed Threshold %  
25

Min Sensor Threshold %  
10

SET



### 7.13 Resonance Avoidance

Resonance avoidance is available for Gen3 motors fitted with vibration sensors. If the feature is not available, the controller will grey out this capability. When a fan is in an application it is recommended to carry out this automatic test during commissioning. Each fan can store up to 5 mask-out ranges which cause vibration above recommended thresholds.

If Generation 2 Fans or the fans that do not have vibration sensors fitted, are connected, the feature is disabled.

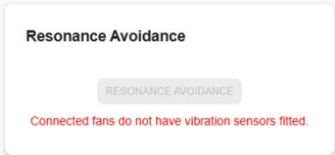

If Generation 3 Fans with fitted vibration sensors are connected, the feature is enabled:

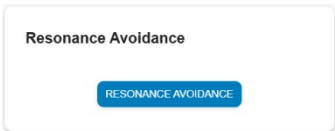

Press the button to enter Resonance avoidance page:

There are two safety checks to complete first. Check the boxes once satisfied and then press “Start Resonance Avoidance” button to start the routine on Fan 1.

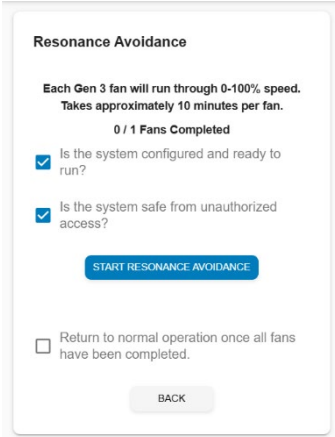
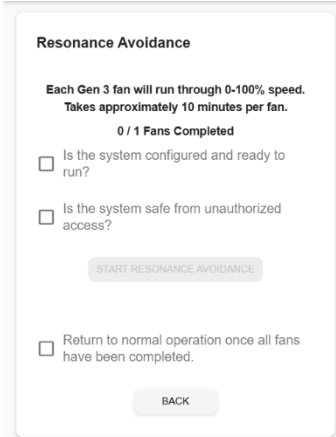

If at least 1 fan has been completed and controller has saved this information, “start Resonance avoidance” will change to “continue Resonance avoidance”.

Press “Rerun resonance avoidance” to erase Controller’s saved information about any previous masks.

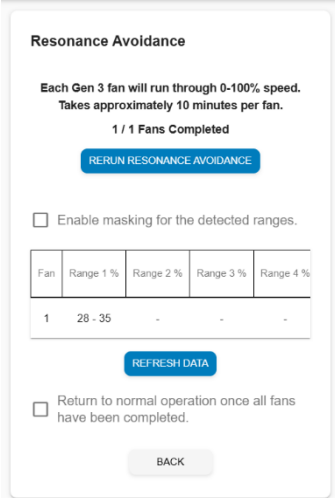
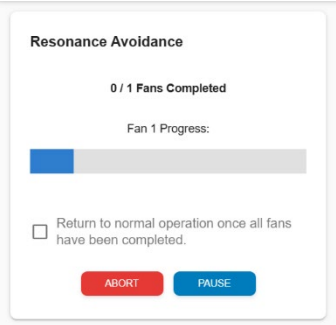

Press “Back” to return to Advanced settings menu.

A table showing the detected resonances will also be displayed for finished fans. When all fans have been completed, and the controller has saved this information, “Enable masking for detected ranges” checkbox will be enabled. Users have an option in selecting either pre or post step change for the mask. See Figures 18 & 19.

The detected ranges information is requested from the fans directly, and if the returned data seems wrong, press “Refresh Data” button to resend the request command to the fans.

If “Return to normal operation once all fans have been completed” is checked, then once all fans have completed the resonance avoidance routine, the controller will return to running the last command.

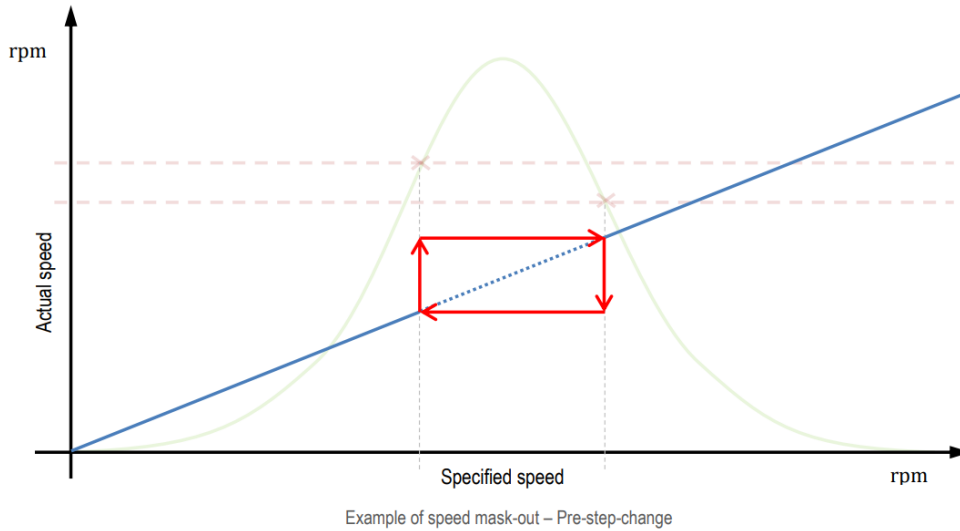

Figure 18 - Resonance avoidance speed mask pre-step change

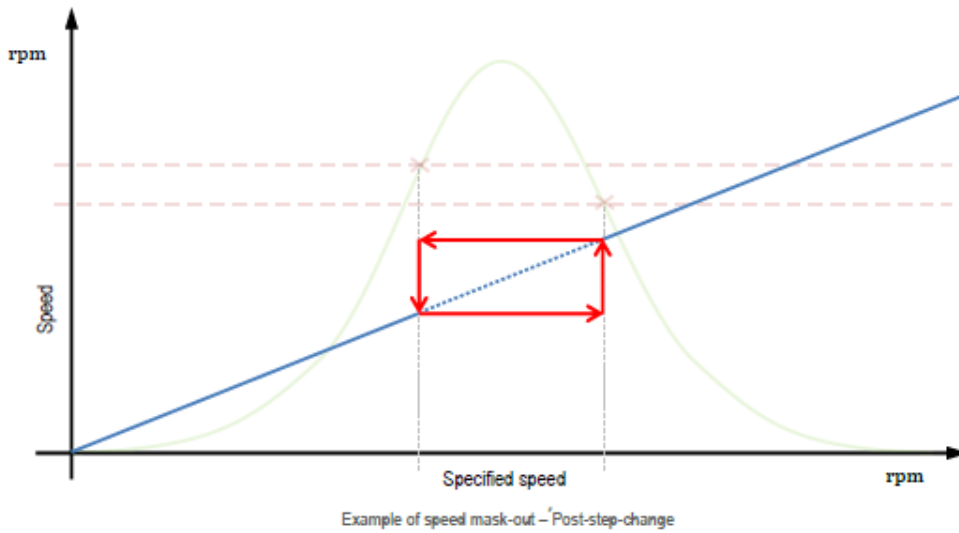

Figure 19 - Resonance avoidance speed mask post-step change

The MMCU delays the start of a test on each fan by 10 seconds to make sure that previous fan has stopped so that it does not interfere with the test.

A progress bar represents 0-100% speed coming back from Fan under test to give an indication of progress.

Pressing the “Abort” button aborts the test and does not save the results for the fan under test.

MMCU: epUK p/n CN1127 – epM p/n 8217139626

Pressing the “Pause” button will pause the test on the next fan. The currently tested fan continues running the resonance routine. When it has completed the test, the speed stays at 100% but the new fan does not start until the “Resume” button is pressed.



### 7.14 Fan Communications Diagnostics

If there are installation / comms issues with the fans, the diagnostics can help identify if the problem is a wiring issue. Selecting a fan number then allows you to ping data to an individual fan and check for responses.

Press “Start” button to run diagnostics on the selected fan.

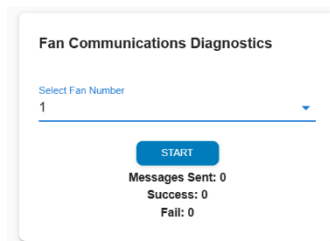
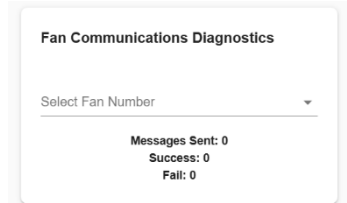

### 7.15 Expansion Modules

The expansion modules are added interfaces for different applications. For example, an Auto/ Hand / Off module (CN1132). Check the box to let the MMCU know that an Expansion Module(s) is/are attached to the MMCU so that it can communicate with them. The expansion modules have a manual addressing dial to differentiate between more than one device.

If any module is detected, their information is displayed in a list.

If no modules were detected, a warning is displayed.

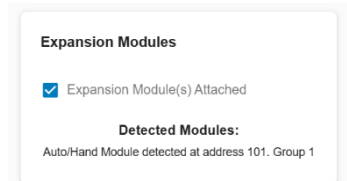
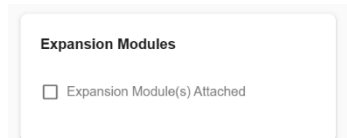



## 7.16 Device Assessment

Device Assessment allows an MMCU to run through a routine to collect the baseline information of the system.

To enter the Device Assessment page, click on “Device Assessment” button.

On page entry, 1 table is shown if 1 fan group is configured, or 2 tables are shown if 2 fan groups are configured. The fans will stop.

If the device assessment has not been run before, Power and Sensor Reading cells are shown as “N/A”, as there is no data saved. If the device assessment has been run before, the last assessment’s data is shown.

Press “Back” button to go to advanced settings page.

To start the device assessment, confirm the checkboxes, which will enable the “Run Device Assessment” button.

During the assessment, the fans run through 0-100% speed, at 10% increments.

On start, the fans run to target 10% speed. Once the target speed has been achieved, the “Next Step” button becomes available. The Power and Sensor Reading values are updated respectively. For user convenience, the highlighted row shows current Control % that is being sent to the fans.

At 100% for Group 1, the “Next Step” button will update to “Confirm” button if 1 fan group is configured, or “Next Group” if 2 fan groups are configured. The same process is repeated for Group 2.

Press “Abort” button to abort the current assessment without saving the data.

**Device Assessment**

Welcome to the Device Assessment page. This page allows you to assess the device's performance and status.

**Group 1 Data**

Control %	Power W	Sensor Reading m³/h
10	8	0
20	N/A	0
30	N/A	0
40	N/A	0
50	N/A	0
60	N/A	0
70	N/A	0
80	N/A	0
90	N/A	0
100	N/A	0

**Group 2 Data**

Control %	Power W	Sensor Reading m³/h
10	N/A	0
20	N/A	0
30	N/A	0
40	N/A	0
50	N/A	0
60	N/A	0
70	N/A	0
80	N/A	0
90	N/A	0
100	N/A	0

Is the system configured and ready to run?

Is the system safe from unauthorized access?

BACK RUN DEVICE ASSESSMENT

**Group 1 Data**

Control %	Power W	Sensor Reading m³/h
10	N/A	0
20	N/A	0
30	N/A	0
40	N/A	0
50	N/A	0
60	N/A	0
70	N/A	0
80	N/A	0
90	N/A	0
100	N/A	0

Waiting for fans to reach target speed...

ABORT NEXT STEP

**Group 1 Data**

Control %	Power W	Sensor Reading m³/h
10	8	3519
20	N/A	0
30	N/A	0
40	N/A	0
50	N/A	0
60	N/A	0
70	N/A	0
80	N/A	0
90	N/A	0
100	N/A	0

ABORT NEXT STEP

Once the assessment has been completed, the data is saved in MMCU’s memory and will be sent to the InSights dashboard if the device is registered for cloud services.



### 7.17 Customer Information

Customer information allows an MMCU to be given a unique identity and location for use when connected to the InSights dashboard. Each entry is alpha numeric. The Customer ID must relate to a given customer country and account reference that will match with their Dashboard workspace. (See InSights OMI for more information for Dashboard connection).

Customer Information

Customer ID: 1  
Site: 1  
Building: 1  
Unit: 1

MODIFY

Customer Information

Customer ID  
1

Site  
1

Building  
1

Unit  
1

MODIFY

### 7.18 Device Information

Device information relevant to the MMCU is displayed in this section.

“Set MMCU to run as a client” checkbox can be set to assist in connecting to the internet via ethernet cable. Some routers take a while to assign an IP address to a client. Checking the box will tell MMCU to indefinitely wait to be assigned an IP address.

The box will automatically be checked if the IP address is assigned within the timeout (10 seconds) window.

Press “Update Device Information” to modify device name and serial number.

Ethernet PHY Speed support the following settings:

- Auto: Auto negotiation
- 10M: 10 Mbps
- 100M: 100 Mbps

Device Information & Settings

Modbus Monitor & Control Unit CN1127  
Serial Number: 50250001  
Device Name: Controller 1  
Device MAC: 24:58:7C:CE:CA:90  
Ethernet IP: 192.168.1.1  
Wi-Fi IP: 192.168.4.1  
Build Time: 13:52:53 Dec 17 2025  
Firmware Version: 2.0.0  
Webserver Version: 2.0.0  
Controller Uptime: 0 hours

UPDATE DEVICE INFORMATION

Set MMCU to run as a client (used when connecting to InSights Dashboard)

Ethernet PHY Speed  
Auto

Reboot required on change

Device Information & Settings

Device Name  
Controller 1

Serial Number  
50250001

UPDATE DEVICE INFORMATION

Ethernet PHY Speed  
Auto

Reboot required on change

**⚠ Note: reboot is required on change.**



## 7.19 Firmware Update

Firmware update via SD Card is used to update the MMCU firmware securely.

Only SD card formatted as FAT32 sizes up to 32GB are supported.

To update the device, insert the SD card with the correct signed and encrypted files (provided by ebm-papst (UK) Ltd), press “Update via SD Card” button and wait for the process to finish, device will restart after the update is complete.

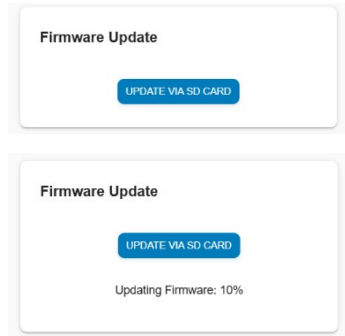

## 8.0 LED Alarm / Warning indications

Mode	LED Sequence
Initial controller power up.	All 3 lights flash once.
Normal operation, no Ethernet or no Wi-Fi or no Cellular connection, Wi-Fi is switched off.	Green pulsing 1sec on, 1sec off.
Normal operation, no Ethernet or no Wi-Fi or no Cellular connection, Wi-Fi is switched on.	Green pulsing 0.25sec on, 0.25sec off.
Normal operation, either Ethernet or Wi-Fi or Cellular connection is made.	Green is on solid.
Normal operation, Ethernet connection is made. Wi-Fi is switched on	Green is on solid for 2sec, then pulses for 2sec 0.25sec on, 0.25sec off.
Controller or/and Fan Warning	Yellow is on solid.
Inhibit signal	Yellow pulsing 1sec on, 1sec off.
Fan Alarm	Red is on solid.
Fan Addressing	Red and Green pulsing 1sec on, 1sec off. Yellow pulses quickly when finding fans
Mode Select	Green pulsing 1sec on, 1sec off, yellow pulsing on-off, red pulsing off-on at 0.25sec rate
Advanced Settings	All 3 lights are on solid.
Sensor Mapping	Sequence of lights: green, yellow, red, all off, repeat.
Resonance Avoidance / Device Assessment	Sequence of lights: red, yellow, green, all off, repeat.

Table 9 - LED indication codes



## 9.0 Replacing the controller

If the controller unit becomes faulty and needs to be replaced, ensure that the new controller is at its factory default settings before connecting it to the fan network. As the fans will already be addressed, you can set up the controller to address the fans using Fan “Existing Fan Array”.

- ⚠ Note 1: The new controller will not identify any set points or configuration parameters from its predecessor other than the fan speed control method e.g. Analogue 0-10V.
- ⚠ Note 2: The new controller must be manually re-configured to fully match its predecessor settings such as Operating Mode, Alarm Mode, BMS Settings, etc.

## 10.0 Replacing a fan

The controller allows a single fan in the array to be replaced at a time. When replacing a fan, using the Webserver, go to any fan’s status screen and then, if the fan to be replaced is still operating:

- Disconnect the fan to be replaced from the RS485 network and wait for the controller to display this fan’s status screen showing a “No Comms” alarm.
- Ensure the mains supply is disconnected.
- Replace the fan and connect the new fan to the RS485 network.
- Switch the new fan ON.
- Wait for the controller to identify the new fan: this will cause the controller to assign the same Modbus address as its predecessor as well as the correct speed control method, depending on the controller’s operating mode. The new fan’s information can be seen on the Fan Status page.

## 11.0 Device Factory Reset

In case the Device’s password is forgotten, a hard reset is necessary. Connect to the device, open any page that requires password entry (Fan Addressing, Mode Select, or Advanced Settings).

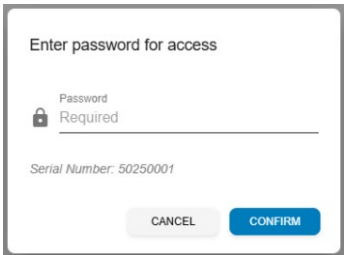

Enter “*ebmMMCUReset*” and press confirm. The dialog box will appear with options to cancel or confirm to proceed with the resetting the device.

The controller will restart and return to the beginning of “Powering up for the first time”. Fan array will have to be auto addressed.

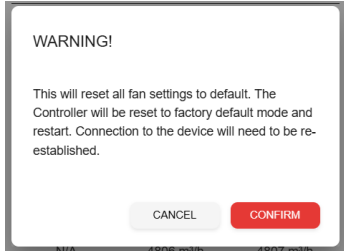

## 12.0 Dimensions

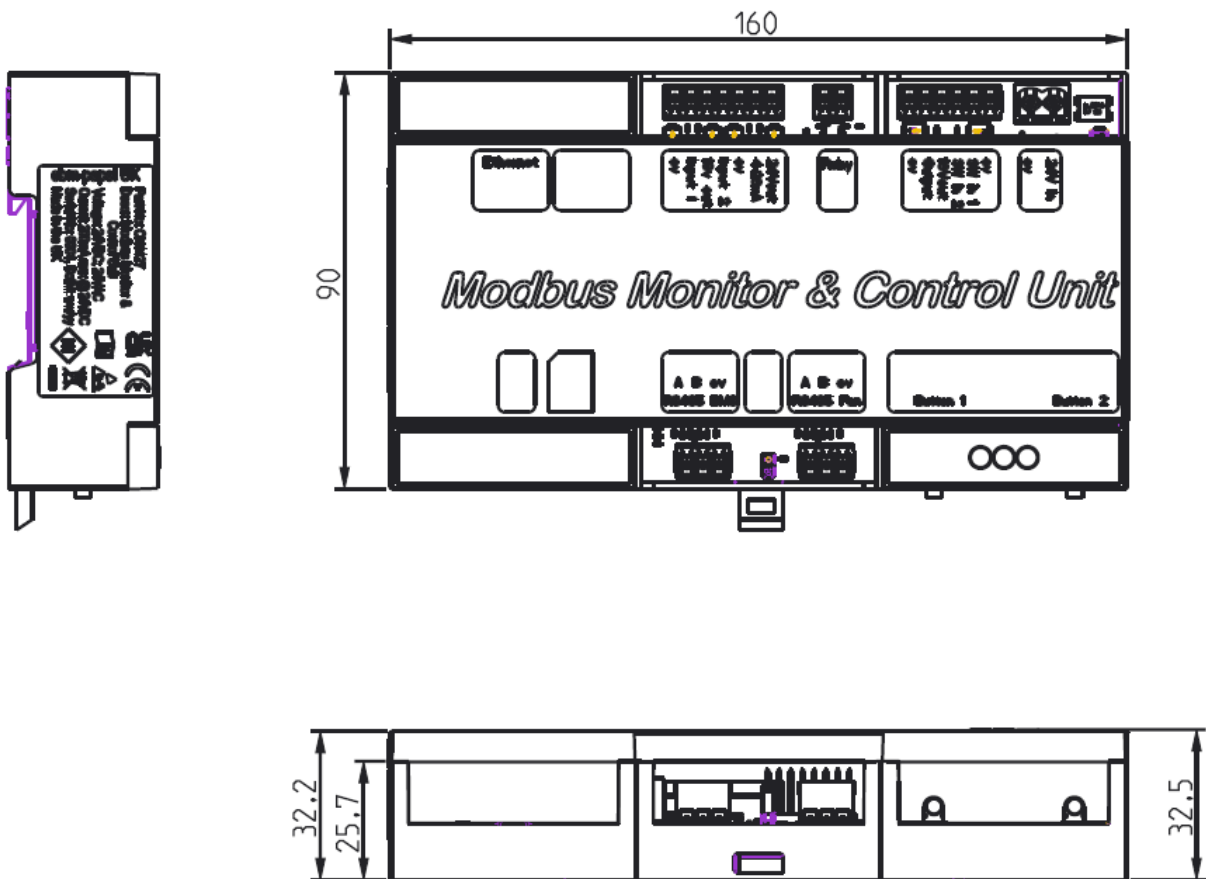

### 13.0 WEEE (Waste Electrical and Electronic Equipment)

ebm-papst UK Ltd complies with the Waste Electrical and Electronic Equipment (WEEE) Regulations through membership of a producer compliance scheme (PCS) as a B2B producer. EEE Producer registration number: WEE/CA0209WR.

### 14.0 End of life

This product has been designed to consider end-of-life disposal. If the product has come to the end of its life, the unit can be easily disassembled for the components to be recycled. The product has been designed to meet the requirements of the REACH & RoHS directives. Refer to the figure below when dismantling.

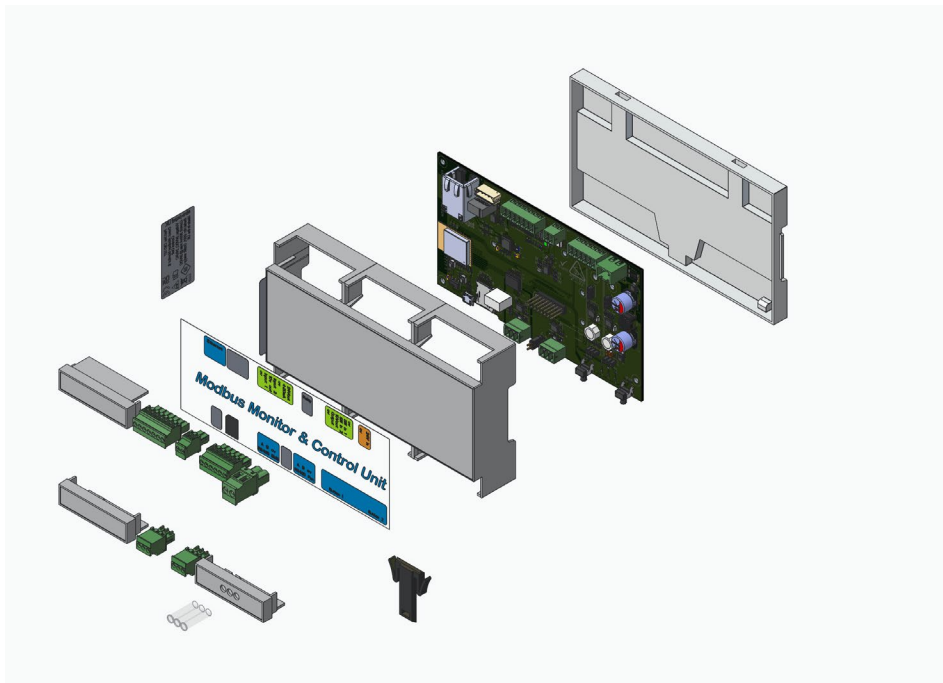

### 15.0 Take back policy

As part of our commitment to minimise the disposal of Waste Electrical and Electronic Equipment (WEEE) customers can return the controller at the end of its life. Please contact us on 01245 468555 for details and issue of an end of life RMA number.

### 16.0 Transport & Storage

PCBs not housed in enclosure should be transported in anti-static build-up bag or static dissipative bags.

- Store in a dry environment.
- Storage temperature: -20°C to +60°C.

### 17.0 Maintenance and servicing

There are no user serviceable parts.



### 18.0 CE Certificates

The product has been CE marked. The certificates are available upon request.

## Appendix A

### A.1 Proportional Control Graph

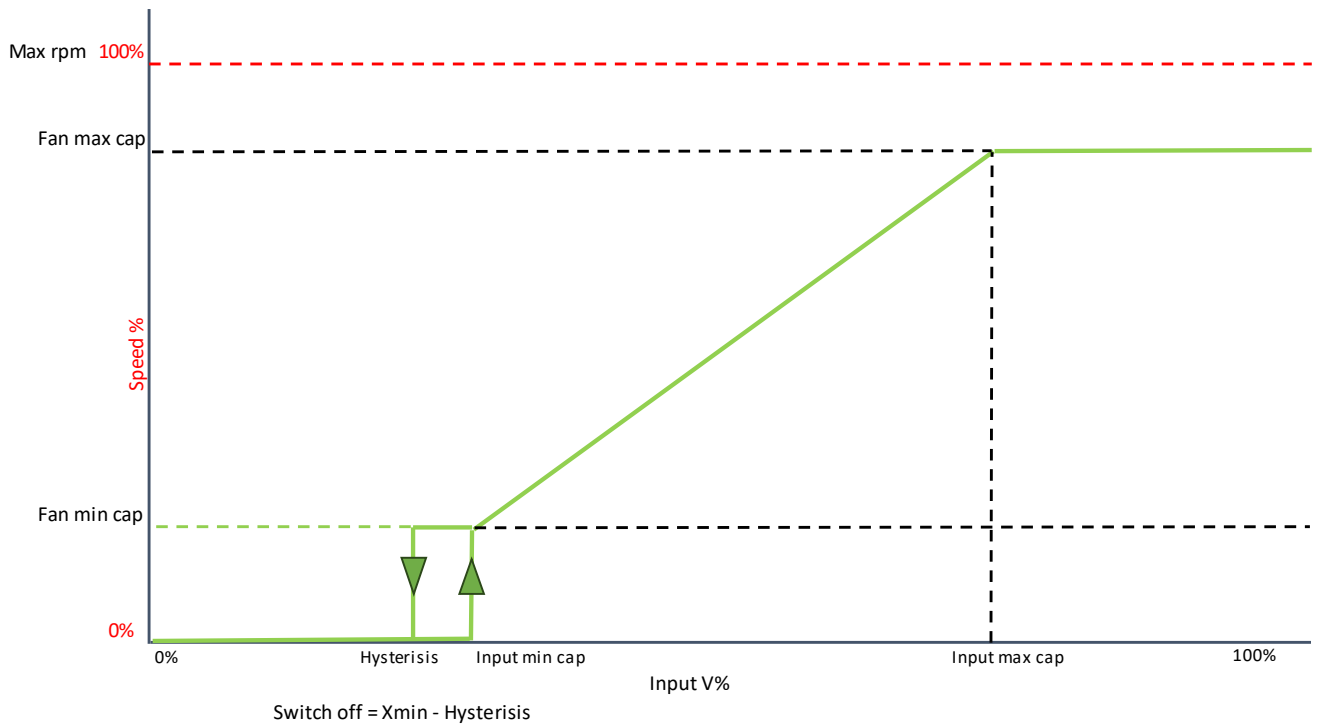



A.2 Constant Volume strategy based on Backward curved centrifugal fan

- 1 1 Nominal setpoint configured with low system resistance.
- 2 2 An increase in system resistance initially reduces volume flow. Speed may remain similar depending on impeller type.
- 3 3 MMCU responds by increasing fan speed and volume to get back to setpoint.
- 4 4 A decrease in system resistance initially increases volume flow. Speed may remain similar depending on impeller type.
- 1 1 MMCU responds by decreasing fan speed and volume to get back to setpoint.

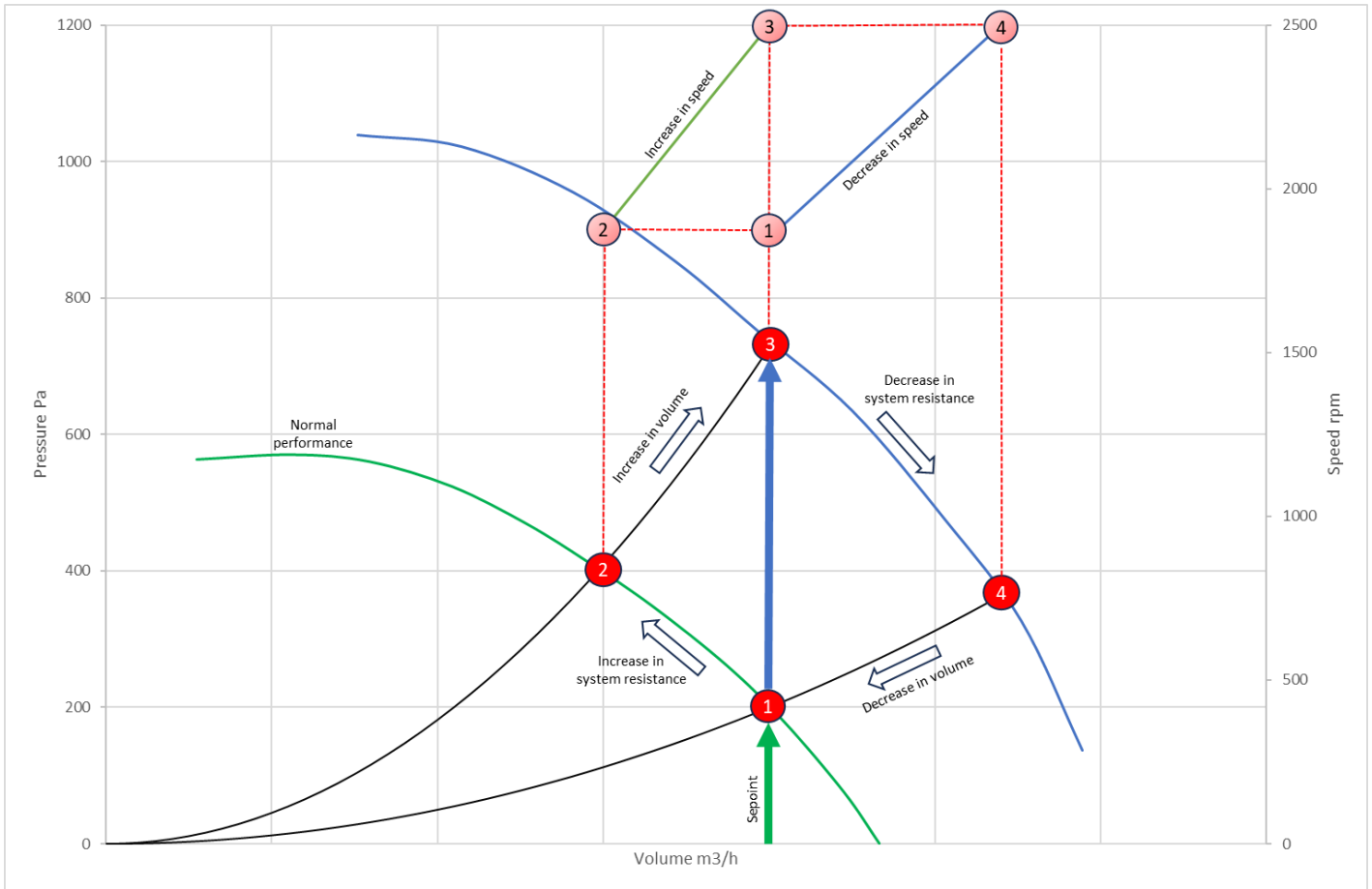

### A.3 Constant Volume with capped fan speed based on Backward curved centrifugal fan

The application should always be designed to allow enough fan performance to cover conditions such as dirty filter or normal increases in system resistance.

If the fan speed has been capped using the Advanced menu, then potentially if the system resistance increases dramatically, it may be impossible to achieve the required setpoint. An alarm is available for that condition. (see 7.12). If a fan failure or failures means that the setpoint can no longer be achieved with the fan speed cap in place there is an option to remove this on fan failure (see 7.4). The implication can be seen in the scenario below.

- 1 Nominal setpoint configured with low system resistance.
- 2 An increase in system resistance initially reduces volume flow. Speed may remain similar depending on impeller type.
- 3 MMCU responds by increasing fan speed and volume to get back to setpoint.
- 4 If the system resistance is beyond the capability of the active fans due to a failure or failures this would cause a reduction in achievable volume if the speed cap is not removed.
- 5 Releasing the speed cap allows the fans to ramp up to maximum speed if required to achieve the setpoint.
- 6 A decrease in system resistance initially increases volume flow. Speed may remain similar depending on impeller type.
- 7 MMCU responds by decreasing fan speed and volume to get back to setpoint and if possible, will reinstate the speed cap.
- 8 A further decrease in system resistance initially increases volume flow. Speed may remain similar depending on impeller type.
- 1 MMCU responds by decreasing fan speed and volume to get back to setpoint.

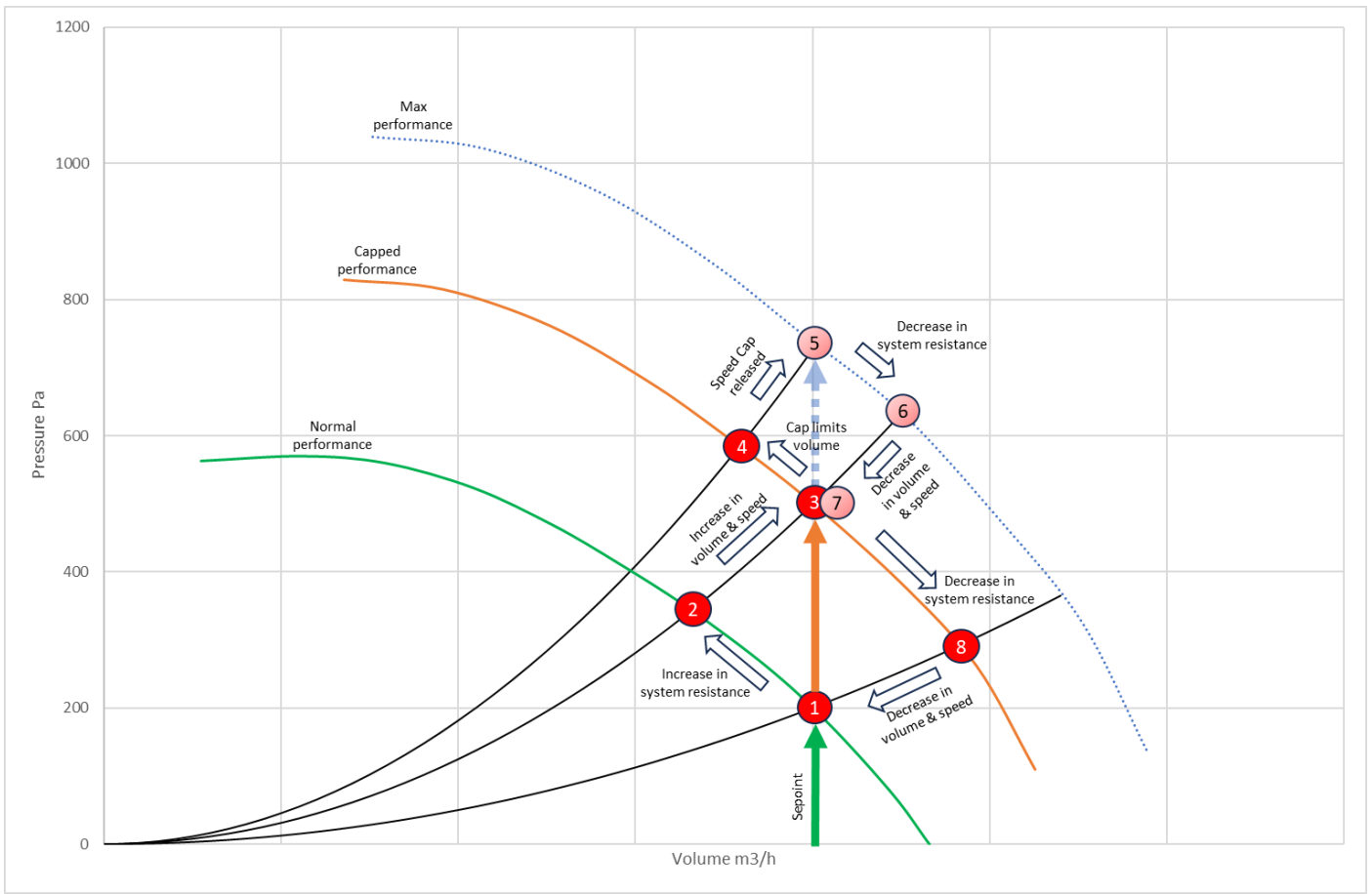



### A.4 Dual setpoint

Example below is set up for 2000 m<sup>3</sup>/h for setpoint 1 and 3300m<sup>3</sup>/h for setpoint 2. Always ensure the fan or fans can achieve the required duty point even under higher system resistance such as a dirty filter condition. The pressure will increase as a square of the volume as performance is increased therefore ensure the fans are designed for the higher back pressures expected.

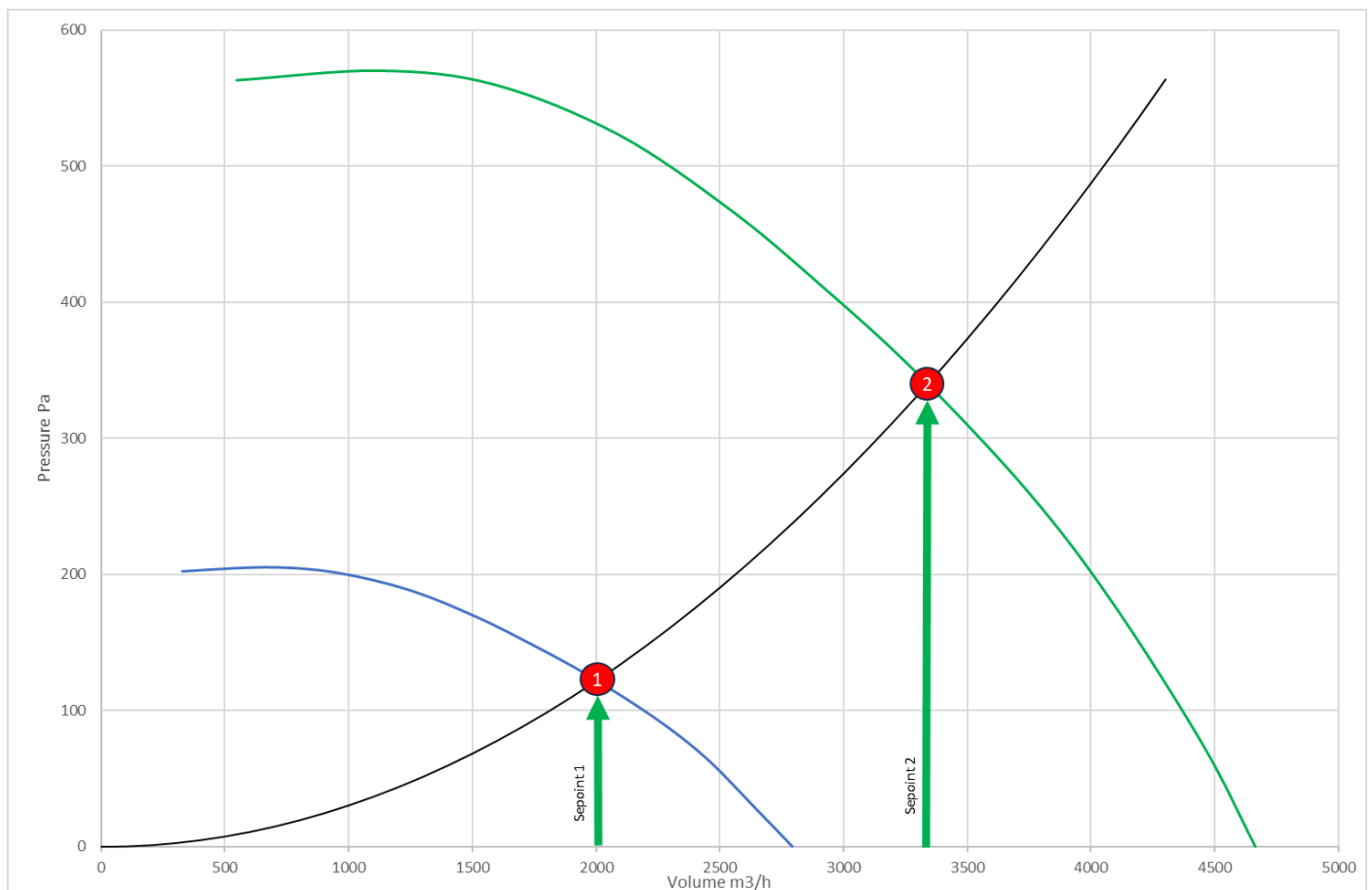



## Appendix B

### B.1 Modbus holding registers for site design

The purpose of the registers below is for system location, configuration and parameter summary.

SITE DESIGN HOLDING REGISTERS			
ADDR (HEX)	ADDR (DEC)	DESCRIPTION	VALUE
64	100	CUSTOMER ID	0-65535; 0 is the default value
65	101	SITE NUMBER	0-65535; 1 is the default value
66	102	BUILDING NUMBER	0-65535; 1 is the default value
67	103	UNIT NUMBER	0-65535; 1 is the default value
68	104	DEVICE ID	1127
69	105	NUMBER OF SITE DESIGN PARAMETERS	65
6A	106	NUMBER OF SYSTEM PARAMETERS	21
6B	107	NUMBER OF POWER UP PARAMETERS	3
6C	108	NUMBER OF FANS	0-99
6D	109	NUMBER OF PARAMETERS/FAN	18

Table 10 - Site design holding registers

### B.2 Modbus holding registers for system configuration and control

SYSTEM CONFIGURATION & CONTROL HOLDING REGISTERS			
ADDR (HEX)	ADDR (DEC)	DESCRIPTION	VALUE
75	117	CONTROL MODE	0 – Monitor; 1 – Webserver; 2 – Proportional control; 3 – Multisource; 4 – Constant Volume / Pressure
76	118	RESERVED	
77	119	RESERVED	
78	120	RESERVED	
79	121	FAN ARRAY SPEED SETPOINT	0 – 1000 representing 0-100.0% Note: Write access only in Control mode 3
7A	122	GROUP 1 SETPOINT 1 HIGH *	0-65535 – higher 16 bits of 32bit unsigned integer
7B	123	GROUP 1 SETPOINT 1 LOW *	0-65535 – lower 16 bits of 32bit unsigned integer
7C	124	GROUP 1 SENSOR INPUT MODE	0 – none; 1 – controller; 2 - fan
7D	125	GROUP 1 SENSOR MAX RANGE	0-3500; representing 0-3500Pa
7E	126	SENSOR MEASUREMENT UNIT	0 – metric; 1 - imperial
7F	127	GROUP 1 SENSOR READING METHOD	0 – average; 1 – minimum; 2 - maximum
80	128	RESERVED	
81	129	RESERVED	
82	130	TOTAL SENSORS	0-99
83	131	CONSTANT SYSTEM TYPE	0 – Volume; 1 - Pressure
84	132	GROUP 1 FAN K FACTOR	0 – 65535; representing k factor of fan inlet ring for volume calc
85	133	PID P VALUE	0 – 65535; 100 default
86	134	PID I VALUE	0 – 65535; 100 default



87	135	PID D VALUE	0 – 65535; 100 default
88	136	GROUP 2 SENSOR INPUT MODE	0 – none; 1 – controller; 2 - fan
89	137	GROUP 2 SENSOR MAX RANGE	0-3500; representing 0-3500Pa
8A	138	GROUP 2 SENSOR READING METHOD	0 – average; 1 – minimum; 2 - maximum
8B	139	GROUP 2 FAN K FACTOR	0 – 65535; representing k factor of fan inlet ring for volume calc
8C	140	GROUP 1 SETPOINT 2 HIGH *	0-65535 – higher 16 bits of 32bit unsigned integer
8D	141	GROUP 1 SETPOINT 2 LOW *	0-65535 – lower 16 bits of 32bit unsigned integer
8E	142	GROUP 2 SETPOINT 1 HIGH *	0-65535 – higher 16 bits of 32bit unsigned integer
8F	143	GROUP 2 SETPOINT 1 LOW *	0-65535 – lower 16 bits of 32bit unsigned integer
90	144	GROUP 2 SETPOINT 2 HIGH *	0-65535 – higher 16 bits of 32bit unsigned integer
91	145	GROUP 2 SETPOINT 2 LOW *	0-65535 – lower 16 bits of 32bit unsigned integer
92	146	SETPOINT MODE	0 – single setpoint; 1 – dual setpoint
93	147	OFFSET VALUE / GROUP 2 SPEED SETPOINT	-99 – 100 represents -99% - 100% / 0 -1000 representing 0 – 100.0% (in Group 2 Independent mode)
94	148	SETPOINT TOGGLE	0 – toggles when SW2 is low; 1 – toggles when SW2 is high
95	149	ENABLE SENSOR MONITOR	0 – disable; 1 - enable
96	150	GROUP 1 FAN SENSOR ANALOGUE INPUT	0 – Ain1 (Gen2) / IO1 (Gen3); 1 – Ain2 (Gen2) / IO2 (Gen3)
97	151	GROUP 2 FAN SENSOR ANALOGUE INPUT	0 – Ain1 (Gen2) / IO1 (Gen3); 1 – Ain2 (Gen2) / IO2 (Gen3)
98	152	GROUP 1 SENSOR INPUT CHOICE	0 – 0-10V1; 1 – 0-10V2; 2 – 4-20mA
99	153	GROUP 2 SENSOR INPUT CHOICE	0 – 0-10V1; 1 – 0-10V2; 2 – 4-20mA
9A	154	ENABLE / DISABLE FANS	0 – fans enabled when SW1 is low; 1 – fans disabled when SW1 is high
9B	155	SWITCH OFF / RUN FANS	0 – fans are switched off below minimum cap value; 1 – fans are running at minimum cap speed below minimum cap value
9C	156	HYSTERISIS	0 -100; 0 when disabled
9D	157	EXTERNAL OUTPUT FOLLOWER	0 – Group 1; 1 – Group 2
9E	158	GROUP 1 SENSOR MAPPING	0 – not complete; 1 - complete
9F	159	GROUP 2 SENSOR MAPPING	0 – not complete; 1 - complete
A0	160	RELAY CONFIGURATION	0 – normally closed; 1 – normally open
A1	161	BMS CONFIGURATION	0 – Modbus RTU; 1 – Modbus TCP
A2	162	BMS SYSTEM RESTART	0 – no restart, 1 – Restart MMCU
A3	163	BMS PASSWORD	0 – 65535. This parameter MUST match the value set via webserver during commissioning. Leave as 0 if not used.
A4	164	GROUP 2 INDEPENDENT CONTROL	0 - group 2 is a follower, 1 - group 2 is independent

Table 11 – System configuration and control holding registers

\*(1) The Target Volume/Pressure is a 32-bit unsigned integer: the high value represents the higher 16-bits and the low value represents the lower 16-bits

(2) For a Constant Pressure system whose measurement unit is set to IMPERIAL, the target pressure setpoint entered here will be the pressure in inch of water times 100 e.g. for a setpoint of 4.010 inch of water, write 0 to the HIGH register and 4010 to the LOW register.

B.3 Modbus holding registers for remote system overview



The purpose of the registers below is for remote monitoring of group 1 and group 2 fan array statuses such as group total power consumption and group total volume or pressure. The registers are read only.

SYSTEM DATA HOLDING REGISTERS			
ADDR (HEX)	ADDR (DEC)	DESCRIPTION	DETAILS
12D	301	CONTROLLER UPTIME SECOND COUNTER HIGH BYTES	THE HIGHER 16-BITS OF A 32-BIT UNSIGNED INTEGER REPRESENTING CONTROLLER SECONDS SINCE LAST RESTART
12E	302	CONTROLLER UPTIME SECOND COUNTER LOW BYTES	THE LOWER 16-BITS OF A 32-BIT UNSIGNED INTEGER REPRESENTING CONTROLLER SECONDS SINCE LAST RESTART
12F	303	GROUP 1 FANS WITH ALARMS	NUMBER OF GROUP 1 FANS DISPLAYING ONE OR MORE ALARM CONDITION
130	304	GROUP 1 FANS WITH NO COMMS	NUMBER OF GROUP 1 FANS NOT RESPONDING TO MODBUS MESSAGES FROM THE CONTROLLER
131	305	GROUP 1 FANS WITH WARNINGS	NUMBER OF GROUP 1 FANS DISPLAYING ONE OR MORE WARNING CONDITIONS
132	306	GROUP 1 NUMBER OF FAILED SENSORS	NUMBER OF GROUP 1 FAILED SENSORS
133	307	GROUP 1 FAN ARRAY SPEED SETPOINT	GROUP 1 FAN ARRAY SPEED SETPOINT (0-100%)
134	308	GROUP 1 TOTAL POWER CONSUMPTION HIGH BYTES	THE HIGHER 16-BITS OF A 32-BIT UNSIGNED INTEGER REPRESENTING THE TOTAL POWER CONSUMPTION OF GROUP 1 FAN ARRAY (W)
135	309	GROUP 1 TOTAL POWER CONSUMPTION LOW BYTES	THE LOWER 16-BITS OF A 32-BIT UNSIGNED INTEGER REPRESENTING THE TOTAL POWER CONSUMPTION OF GROUP 1 FAN ARRAY (W)
136	310	GROUP 1 TOTAL VOLUME/PRESSURE HIGH BYTES	THE HIGHER 16-BITS OF A 32-BIT UNSIGNED INTEGER REPRESENTING GROUP 1 SENSOR READING IN m3/h, CFM, Pa or INWG (0-65535) *
137	311	GROUP 1 TOTAL VOLUME/PRESSURE LOW BYTES	THE LOWER 16-BITS OF A 32-BIT UNSIGNED INTEGER REPRESENTING GROUP 1 SENSOR READING IN m3/h, CFM, Pa or INWG (0-65535) *
138	312	GROUP 2 FANS WITH ALARMS	NUMBER OF GROUP 2 FANS DISPLAYING ONE OR MORE ALARM CONDITION
139	313	GROUP 2 FANS WITH NO COMMS	NUMBER OF GROUP 2 FANS NOT RESPONDING TO MODBUS MESSAGES FROM THE CONTROLLER
13A	314	GROUP 2 FANS WITH WARNINGS	NUMBER OF GROUP 2 FANS DISPLAYING ONE OR MORE WARNING CONDITIONS
13B	315	GROUP 2 NUMBER OF FAILED SENSORS	NUMBER OF GROUP 2 FAILED SENSORS
13C	316	GROUP 2 FAN ARRAY SPEED SETPOINT	GROUP 2 FAN ARRAY SPEED SETPOINT (0-100%)
13D	317	GROUP 2 TOTAL POWER CONSUMPTION HIGH BYTES	THE HIGHER 16-BITS OF A 32-BIT UNSIGNED INTEGER REPRESENTING THE TOTAL POWER CONSUMPTION OF GROUP 2 FAN ARRAY (W)
13E	318	GROUP 2 TOTAL POWER CONSUMPTION LOW BYTES	THE LOWER 16-BITS OF A 32-BIT UNSIGNED INTEGER REPRESENTING THE TOTAL POWER CONSUMPTION OF GROUP 2 FAN ARRAY (W)
13F	319	GROUP 2 TOTAL VOLUME/PRESSURE HIGH BYTES	THE HIGHER 16-BITS OF A 32-BIT UNSIGNED INTEGER REPRESENTING GROUP 2 SENSOR READING IN m3/h, CFM, Pa or INWG (0-65535) *
140	320	GROUP 2 TOTAL VOLUME/PRESSURE LOW BYTES	THE LOWER 16-BITS OF A 32-BIT UNSIGNED INTEGER REPRESENTING GROUP 2 SENSOR READING IN m3/h, CFM, Pa or INWG (0-65535) *

Table 12 - System data holding registers

\* If "Unit Type = Pressure" and "Measurement Unit = Imperial" then the value is presented as (INWG x 1000)

B.4 Modbus holding registers for individual fan monitoring



The purpose of the registers is for remote monitoring of individual fans of the system. A “2-Fan Array” is used as an example. This set of registers scales up and down depending on the total connected fans.

Parameter N°	ADDR (hex)	DESCRIPTION (Locally Stored Registers)
Parameter 1	CB00	FAN 1 - FAN STATUS (0= No Comms, 1= Healthy, 2= Alarm, 3= Warning)
	CB01	FAN 2 - FAN STATUS (0= No Comms, 1= Healthy, 2= Alarm, 3= Warning)
Parameter 2	CB02	FAN 1 – ALARM REGISTER *
	CB03	FAN 2 – ALARM REGISTER *
Parameter 3	CB04	FAN 1 – WARNING REGISTER *
	CB05	FAN 2 – WARNING REGISTER *
Parameter 4	CB06	FAN 1 - POWER (W)
	CB07	FAN 2 - POWER (W)
Parameter 5	CB08	FAN 1 - SPEED (RPM)
	CB09	FAN 2 - SPEED (RPM)
Parameter 6	CB0A	FAN 1 - RPM LIMIT (RPM)
	CB0B	FAN 2 - RPM LIMIT (RPM)
Parameter 7	CB0C	FAN 1 - MOTOR TEMPERATURE (°C)
	CB0D	FAN 2 - MOTOR TEMPERATURE (°C)
Parameter 8	CB0E	FAN 1 - ELECTRONICS TEMPERATURE (°C)
	CB0F	FAN 2 - ELECTRONICS TEMPERATURE (°C)
Parameter 9	CB10	FAN 1 - HOURS RUN (hours)
	CB11	FAN 2 - HOURS RUN (hours)
Parameter 10	CB12	FAN 1 – SPEED SETPOINT (0-100%)
	CB13	FAN 2 – SPEED SETPOINT (0-100%)
Parameter 11	CB14	FAN 1 - SENSOR READING (m3/h, Pa, cfm, in.w.g) **
	CB15	FAN 2 - SENSOR READING (m3/h, Pa, cfm, in.w.g) **
Parameter 12	CB16	FAN 1 - VIBRATION SENSOR STATUS REGISTER ***
	CB17	FAN 2 - VIBRATION SENSOR STATUS REGISTER ***
Parameter 13	CB18	FAN 1 - VIBRATION VELOCITY X (HARMONIC) ****
	CB19	FAN 2 - VIBRATION VELOCITY X (HARMONIC) ****
Parameter 14	CB20	FAN 1 - VIBRATION VELOCITY Y (HARMONIC) ****
	CB21	FAN 2 - VIBRATION VELOCITY Y (HARMONIC) ****
Parameter 15	CB22	FAN 1 - VIBRATION VELOCITY Z (HARMONIC) ****
	CB23	FAN 2 - VIBRATION VELOCITY Z (HARMONIC) ****
Parameter 16	CB24	FAN 1 - VIBRATION VELOCITY X (RMS) ****
	CB25	FAN 2 - VIBRATION VELOCITY X (RMS) ****
Parameter 17	CB26	FAN 1 - VIBRATION VELOCITY Y (RMS) ****
	CB27	FAN 2 - VIBRATION VELOCITY Y (RMS) ****
Parameter 18	CB28	FAN 1 - VIBRATION VELOCITY Z (RMS) ****
	CB29	FAN 2 - VIBRATION VELOCITY Z (RMS) ****

Table 13 - Locally stored fan data holding registers

MMCUC: epUK p/n CN1127 – epM p/n 8217139626

\* See Table 14 below for information about the fan alarm and fan warning registers

\*\* in.w.g scaled value is represented as “Value \* 1000”.

\*\*\* See Table 15 below for information about the Vibration Sensor Status Register. This register is not available for Gen 2 fans, the value will be 0.

\*\*\*\* Vibration Velocity Registers are represented as “Value \* 10”. For example, value “25” corresponds to “2.5 mm/s”. These registers are not available for Gen 2 fans, the value will be 0.

For parameter, the equation below can be used to derive the Modbus Address (in decimal):

**Modbus Address = 51967 + (Parameter Number \* Total Fans) - (Total Fans – Fan Number)**

**⚠ NOTE:** Do not to read/write more than 50 consecutive registers at a time, otherwise a Modbus Exception Response will occur.



B.5 Fan Alarm and Warning Register

**FAN ALARM REGISTER**

Coding:

MSB	0	0	0	UzLow	0	RL_Cal	0	n_Limit
LSB	BLK	HLL	TFM	FB	SKF	TFE	0	PHA

If a bit has been set, the error described below has occurred:

- UzLow: DC-link undervoltage
- RL\_Cal: Rotor position sensor calibration error (see also 2.63.1)
- n\_Limit: Speed limit exceeded
  
- BLK: Motor blocked
- HLL: Hall sensor error
- TFM: Motor overheated
- FB: Fan Bad (general error \*)
- SKF: Communication error between master controller and slave controller
- TFE: Output stage overheated
- PHA: Phase failure (3~ devices) or supply voltage too low (1~ devices)

\*) "Fan Bad" is set for every error

**FAN WARNING REGISTER**

MSB	LRF	UeHigh	0	UzHigh	0	OpenCir.	n_Low	RL_Cal
LSB	Brake	UzLow	TEI_high	TM_high	TE_high	P_Limit	L_high	I_Limit

- LRF : Shedding function active - (see 0 Shedding function)
- UeHigh : Line voltage high
- UzHigh : DC-link voltage high
- OpenCir. : Open circuit at analog input or PWM input for the set value (voltage at analog input < open circuit limit value - see 2.52, or signal at PWM input statically high)
- n\_Low : Actual speed is lower than speed limit for running monitoring (see 0)
- RL\_Cal : Calibration of rotor position sensor in progress (see 2.63.1)
  
- Brake : Braking mode: set in the case of external drive in opposite direction at high speed for lengthy period
- UzLow : DC link voltage low
- TEI\_high : Temperature inside electronics high
- TM\_high : Motor temperature high
- TE\_high : Output stage temperature high
- P\_Limit : Power limiter in action
- L\_high : Line impedance too high (DC-link voltage unstable)
- I\_Limit : Current limitation in action

Table 14 - Fan alarm & warning registers



B.6 Fan Vibration Sensor Status Register

Coding:

MSB	0	0	0	0	0	Filter	RMS	Harm.
LSB	0	0	0	Ranges	GI_Err	Test run	Limit	Mask-out

The setting of bit activates the status:

- Filter : Vibration velocity (filtered) limit value (see 0) exceeded
- RMS : Vibration velocity (RMS) limit value (see 0) exceeded
- Harm. : Vibration velocity (harmonic) limit value (see 0) exceeded
- Ranges : More than 5 ranges were detected in the test run (see 0)
- GI\_Err : Communication with vibration sensor interrupted
- Test run : Test run interval elapsed (more than 6 months since last test run)
- Limit : Vibration velocity limit value (see 0) exceeded (collective message)  
is set if a vibration velocity (filter, RMS, harmonic) has been exceeded.  
Possibly not synchronous with individual messages due to low-pass behavior.
- Mask-out : Set value is masked-out (operating set value is within a mask-out range)

Table 15 – Fan vibration sensor status register



B.7 Modbus Direct fan access

Use below Modbus Direct fan access registers to communicate with a fan directly. It is only possible to access the registers of one fan at a time. Fan Modbus Address Register 0x1FF value can be set to change the communicating fan. Generation 3 Fans support D000 – D67F, but more addresses are reserved for future expansion. Functions Read Holding Registers (0x03), Read Input Registers (0x04), and Write Single Register (0x06) are supported. For more information on the available fan registers please consult the relevant version of Modbus specification for the generation of fan motor used.

**Example of communicating with Fan 4 to set its speed to 100%:**

BMS writes “4” to Fan Modbus Address Register 0x1FF, then “65535” to holding register 0x201, which is equivalent to Holding register D001 of Fan 4.

ADDR (HEX)	ADDR (DEC)	DESCRIPTION	DETAILS
1FF	511	FAN MODBUS ADDRES	SELECT FAN MODBUS ADDRESS. 0 TO BROADCAST TO ALL FANS IN THE SYSTEM
200	512	START ADDRESS	FAN X ADDRESS D000
9FF	2559	END ADDRESS	FAN X ADDRESS D7FF

Table 16 - Modbus Direct fan access holding registers

- ⚠ NOTE 1:** Do not read/write more than 9 (Gen2) or 14 (Gen3) consecutive “retrieved from fan” registers at a time, otherwise a Modbus Exception Response will occur.
- ⚠ NOTE 2:** The controller will respond to the BMS after the communication with the fan has completed. A Modbus Exception Response will be returned to the BMS if the read/write to the fan has failed or the fan has no comms.



## Appendix C

### C.1 Change notes v2.0.0

- Major security updates in compliance with EN18301-1
- Added rollback support
- Added an option to select Modbus TCP during Setup stage
- Added an option to select ethernet driver configuration (Auto/100/10)
- Added an option to reset Controller only
- Removed Engineer's password
- Yellow LED is now set on warnings to align with fan alarms
- Yellow LED is now flashing when Fans Inhibit signal is received
- Added indicator to show when the device is connecting and sending data to InSights dashboard
- Device name, customer ID, Site, Building and Unit character limit increased to 25 characters
- Improvements to SD card update process
- UI improvements
- Bug fixes
- Firmware improvements and optimisations

[www.ebmpapst.com](http://www.ebmpapst.com)

**ebmpapst**

engineering a better life

**ebm papst UK**  
Chelmsford Business Park,  
CM2 5EZ, United Kingdom  
+44 (0) 1245 456530  
[info@uk.ebmpapst.com](mailto:info@uk.ebmpapst.com)