



Operating Instructions

ebm-papst A&NZ Pty Ltd
10 Oxford Road
Laverton North VIC 3026
Australia
Phone: +61 3 9360 6400
Fax: +61 3 9360 6464
sales@ebmpapst.com.au
www.ebmpapst.com.au

CONTENTS

1.	SAFETY REGULATIONS AND NOTES	1
2.	TECHNICAL DATA	2
2.1	Product drawing.....	2
2.2	Ancillary component data	2

1. SAFETY REGULATIONS AND NOTES

Please read these operating instructions carefully before starting to work with the device. Observe the following warnings to prevent malfunctions or physical damage to both property and people.

Product S4E350AN02CT-048 is assembled in Australia and incorporates imported product A4E350AN0232.

For product drawing see Chapter 2.1 'Product drawing' of this document and Chapter 2.2 'Ancillary component data' for specifications of sub components.

For safety regulations and information, intended use, technical data, connection and start-up and maintenance, malfunctions, possible causes and remedies refer to operating instructions of A4E350AN0232.

These operating instructions are to be regarded as part of this device. If the device is sold or transferred, the operating instructions must accompany it.

These operating instructions may be duplicated and forwarded for information about potential dangers and their prevention.



Operating Instructions

2. TECHNICAL DATA

2.1 Product drawing

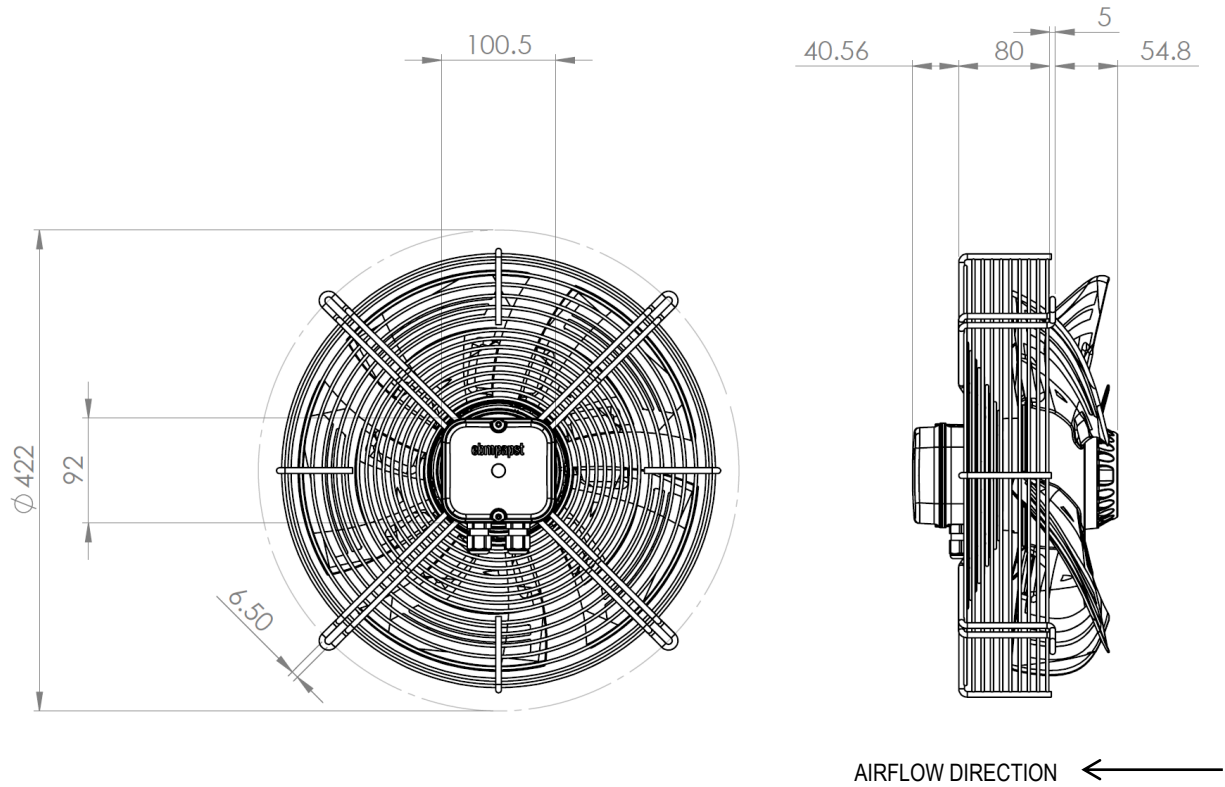

All dimensions are in mm

Direction of air flow "V"

Fan cable requirement

Cable diameter: max 7.5 mm, tightening torque for cable gland 1.3 ±0.2 Nm.

Fan junction box requirements

Tightening torque 3.5±0.5 Nm for 2x screws on lid.

2.2 Ancillary component data

Weight [kg]	4.98
Material of guard grille	Steel phosphate and coated in black
Material of junction box	ABS plastics



Operating Instructions

3. CONNECTION AND START-UP

3.1 Connecting the electrical system

NOTE

Water ingress into wires or cables

- Make sure the end of the cable is connected in a dry environment.
- The degree of protection is only assured when the intended cable guard and terminal box are installed.

3.2 Preparing connection lines for the connection

Strip the cable just enough so that the screwed cable gland is tight and the terminals are relieved of strain. Tightening torque, see Chapter 2.1 'Product drawing'.

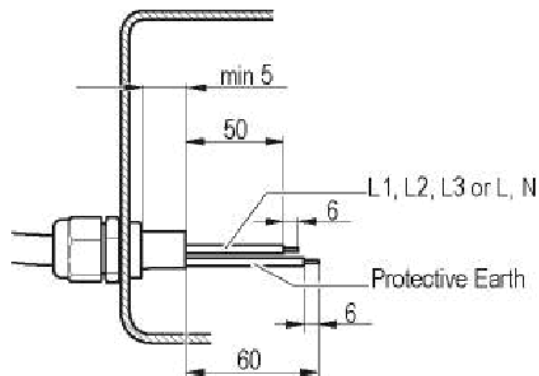

Fig. 1: Preparing cables for terminal box.

3.3 Connecting cables with terminals

WARNING

Terminals and connections have voltage even with a unit that is shut off

Electric shock

- Wait five minutes after disconnecting the voltage at all poles before opening the device.
- Remove the cap from the screwed cable gland. Remove the cap only in those places where cables are inserted.
- Insert the line(s) (not included in the standard scope of delivery) into the terminal box.
- First connect the "PE" (protective earth) connection.
- Connect the lines to the corresponding terminals. Use a screwdriver to do so. During the connection work, ensure that no cables splice off.
- Seal the terminal box.