



# Operating Instructions

ebm-papst A&NZ Pty Ltd  
10 Oxford Road  
Laverton North VIC 3026  
Australia  
Phone: +61 3 9360 6400  
Fax: +61 3 9360 6464  
[sales@ebmpapst.com.au](mailto:sales@ebmpapst.com.au)  
[www.ebmpapst.com.au](http://www.ebmpapst.com.au)

## CONTENTS

<b>1. SAFETY REGULATIONS AND NOTES</b> .....	<b>1</b>
<b>2. TECHNICAL DATA</b> .....	<b>2</b>
2.1 Product drawing.....	2
2.2 Ancillary component data .....	2

## 1. SAFETY REGULATIONS AND NOTES

Please read these operating instructions carefully before starting to work with the device. Observe the following warnings to prevent malfunctions or physical damage to both property and people.

Product W2E250CE6502 is assembled in Australia and incorporates imported product A2E250AE6502.

For product drawing see Chapter 2.1 'Product drawing' of this document and Chapter 2.2 'Ancillary component data' for specifications of sub components.

For safety regulations and information, intended use, technical data, connection and start-up and maintenance, malfunctions, possible causes and remedies refer to operating instructions of A2E250AE6502.

These operating instructions are to be regarded as part of this device. If the device is sold or transferred, the operating instructions must accompany it.

These operating instructions may be duplicated and forwarded for information about potential dangers and their prevention.



# Operating Instructions

## 2. TECHNICAL DATA

### 2.1 Product drawing

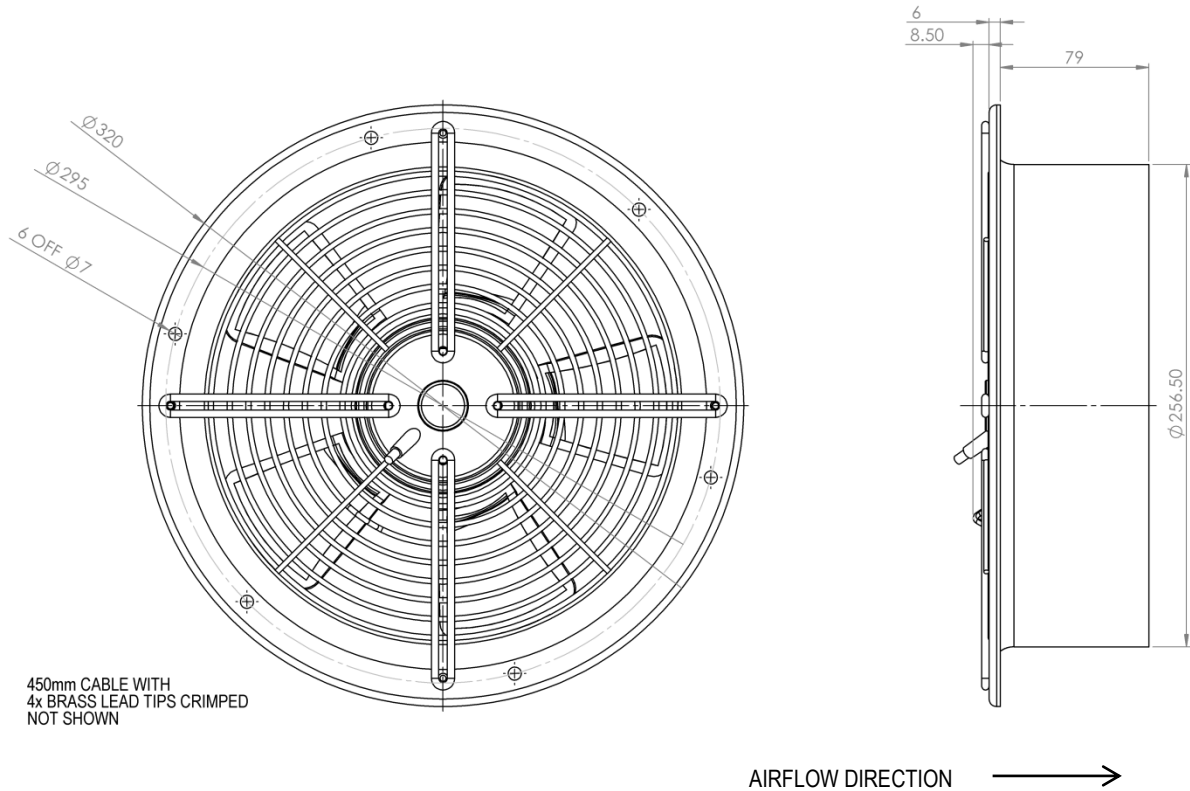

All dimensions are in mm

Direction of air flow "A"

#### Cable

Customer end stripped 85 mm  
4x brass lead tips crimped.

### 2.2 Ancillary component data

Mass	4.98 kg
Material of guard grille	Steel phosphate and coated in black
Material of wall ring	Sheet steel pre-galvanised and coated in black plastic
Capacitor	3.5 $\mu$ F, S0