

Energy-saving axial fans

A solution specifically designed for unit cooler applications.

ebmpapst

The engineer's choice



10-Position
rotary switch



New S1G305 series designed for unit cooler applications

Unit Cooler

The new S1G305 series uses 30% less power than typical unit cooler fans with PSC motors. Specifically designed for unit cooler applications, the S1G305 fan series is equipped with a very efficient electronically commuted, permanent magnet motor. Motor, blade, power cable and three mounting options are integrated and available as a single part number. The S1G305 fans are equally suited for both OEM and retrofit use.

Fan replacement or retrofit of walk-in evaporators is a breeze with the winning combination of wide voltage range and rotary speed selection on the S1G305 series!



Standard Features

- » 835 CFM at 41 watts input power at free air
- » Same performance operating on 50 or 60 Hz
- » Maintains performance over wide voltage range (100-240 VAC)
- » Efficient, small frame EC external rotor motor reduces power and mounting depth
- » Mounting depth only 2.86" (including mounting stud flange)
- » Integrated assembly reduces purchasing and manufacturing logistics
- » Multi-mount design provides three bolt-circles for choice of mounting
- » 12" diameter composite, aerodynamic blade is installed and balanced
- » Grounding protection Class II - no ground wire needed
- » Protection Class IP54
- » EMF P-2-1-075 compatible plug connection on 12" jacketed cable
- » Allows use of existing fan guards

Options

- » 10 position rotary switch for setting speed (P/N S1G305-DA02-10)
- » Two speed
- » Variable speed



EC axial fans

Sickled blades (S-series) single inlet Ø 305



Highlights:

- Motor current limit
- Soft start
- Over-temperature protected electronics
- Locked rotor protection

Material: Blades and struts: PP plastic

Mounting position: Shaft horizontal with the harness in the 6 o'clock position

Condensate discharge holes: None

Direction of rotation: Clockwise, seen on rotor

Nominal Data

Type	Motor	Voltage range VAC	Frequency Hz	Power input (1) W	Speed RPM	Current draw (1) A	Max back pressure in. wg	Temperature range °C	Weight lbs	Description
S1G305-DA02-07	M1G055-DF	100...240	50/60	63	1590	0.90	0.30	-40...40	3.6	Single speed
S1G305-DA02-10	M1G055-DF	100...240	50/60	70	1650 ⁽²⁾	0.98	0.35	-40...40	3.6	10-speed rotary switch

(1) Nominal data at maximum load and 115 VAC.

(2) Speed settings (rpm): 900, 1100, 1200, 1300, 1400, 1450, 1500, 1550, 1600, 1650

S1G305-DA02-07 Performance Curve

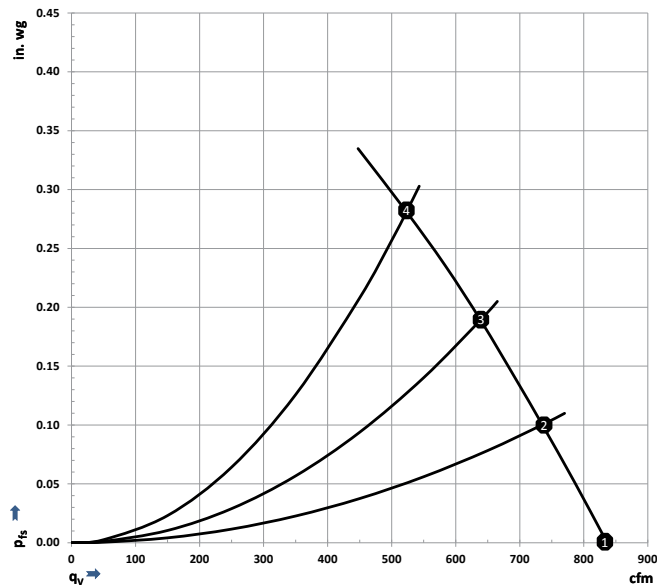

Air performance measured on an air chamber designed to meet ISO AMCA210-99 and ISO 5801, with fan installed as per ISO 5801 Installation Category A but without protection against accidental contact.

The fan was mounted in a square-edged orifice to simulate worst case unit cooler applications.

The values given are valid under the measuring conditions mentioned and may vary according to the actual installation situation.

For detailed information on the measurement set-up, please contact ebm-papst.

	n rpm	Pe W	I ⁽³⁾ A
①	1599	41.4	0.58
②	1596	48.2	0.67
③	1596	52.6	0.73
④	1595	57.2	0.80

(3) Current shown at 115 VAC

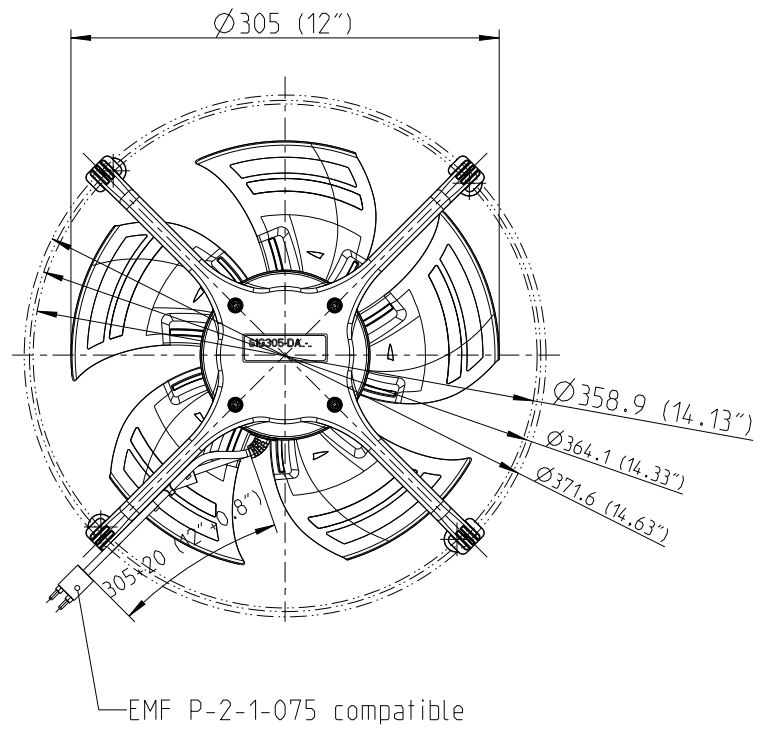
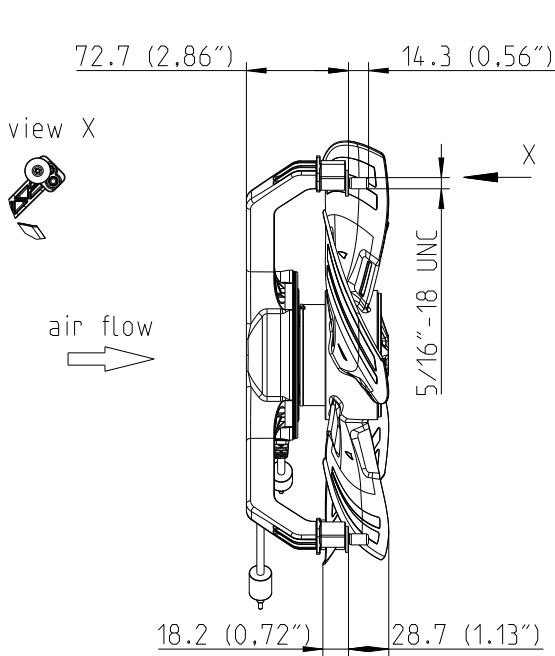

S1G305-DA02-10 performance curves for the 10 speed settings

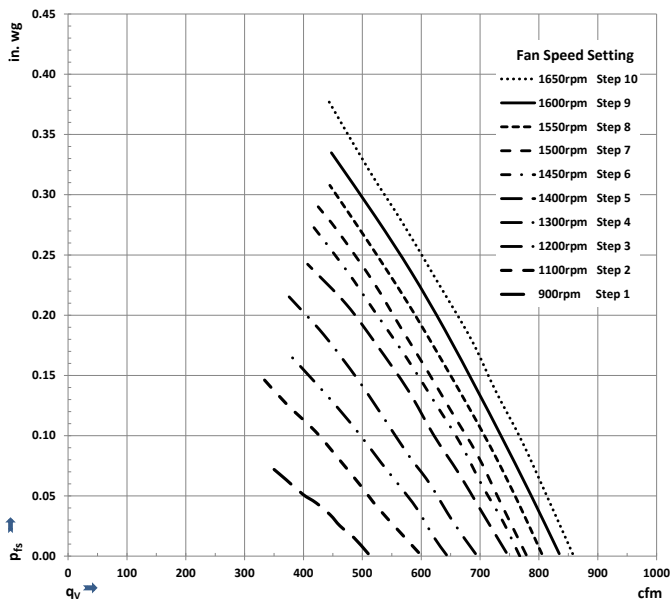

Air performance measured on an air chamber designed to meet ISO AMCA210-99 and ISO 5801, with fan installed as per ISO 5801 Installation Category A but without protection against accidental contact.

The fan was mounted in a square-edged orifice to simulate worst case unit cooler applications.

The values given are valid under the measuring conditions mentioned and may vary according to the actual installation situation.

For detailed information on the measurement set-up, please contact ebm-papst.

View of rotary switch speed selector shown without cover plate. Unit otherwise dimensionally the same as the single speed S1G305-DA02-07.

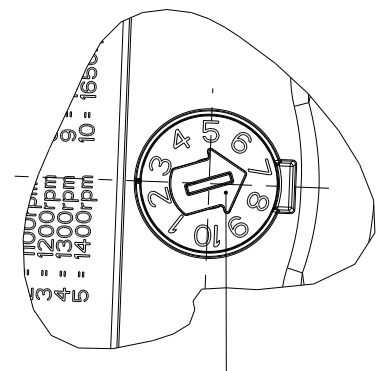

Speed selector shown set to #7, equal to 1500 rpm.

Notes

S1G305 field replacement guide

Step-by-step visual instructions

The ebm-papst S1G305 unit cooler fan assembly can be used to replace failed EC, PSC or shaded pole inefficient motor/blade/mount assemblies providing a quick repair and immediate energy savings by upgrading to an EC motor.

Standard evaporator with motor, blade and mounting fixture.

1

Remove existing finger guard and nuts for re-use.



Scan here to see for yourself how easy the S1G305 makes replacing a broken or inefficient fan assembly!

Or visit our YouTube channel at <https://www.youtube.com/user/ebmpapstUSA>



S1G305 field replacement guide

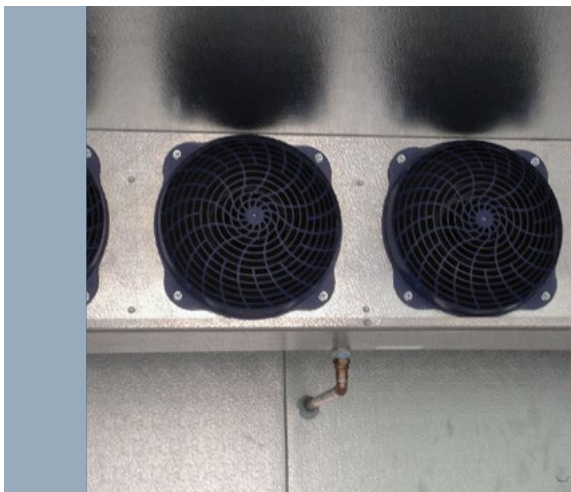
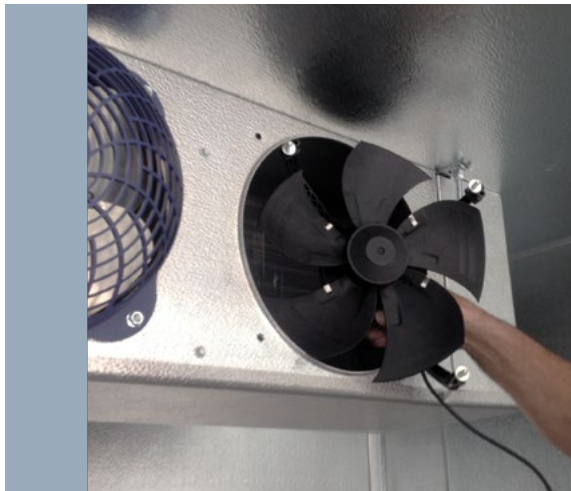
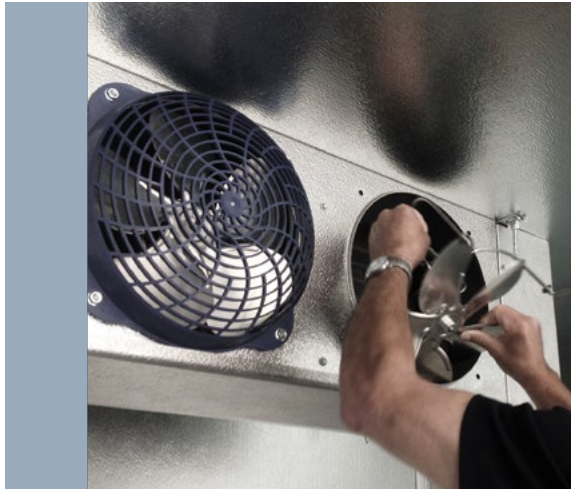

2

Remove existing fan, blade and mount as complete assembly - no disassembly required since these parts will not be required.

3

Install the new preassembled ebm-papst EC fan with existing hardware.

4

Final installation re-using existing fingerguards.

**ebm-papst Inc.
North America**

100 Hyde Road
Farmington, CT 06034
Phone + 1 860-674-1515
Fax + 1 860-674-8536
sales@us.ebmpapst.com
© ebm-papst Inc. 2016.
ebm-papst Inc. reserves the right to change any specifications or data without notice

ebmpapst

The engineer's choice