

RadiPac with *resonance avoidance*.

Longer service life based on condition monitoring.

ebmpapst

the engineer's choice



About ebm-papst.

ebm-papst is a leader in ventilation and drive engineering technology and a much sought-after engineering partner in many industries. With around 20,000 different products, we have the perfect solution for practically every requirement. We believe the consistent further development of our highly-efficient GreenTech EC technology provides our customers with the best opportunities for the future in industrial digitization. With GreenIntelligence, ebm-papst already offers intelligent networked complete solutions that are unique anywhere in the world today.

ebmpapst

the engineer's choice

Six reasons that make us the ideal partner:

Our systems expertise: as experts in advanced motor technology, electronics and aerodynamics, we provide system solutions from a single source.

Our spirit of invention: our 600 engineers and technicians will develop a solution that precisely fits your needs.

Our lead in technology: with our EC technology and GreenIntelligence, we combine the highest energy efficiency with the advantages of IoT and digital networking.

Closeness to our customers: at 48 sales offices worldwide.

Our standard of quality: our quality management is uncompromising, at every step in every process.

Our sustainable approach: we assume responsibility with our energy-saving products, environmentally-friendly processes, and social commitment.

GreenIntelligence. *Making Engineers Happy.*



Why do our customers look so happy? Because when it comes to the Internet of Things and the digital transformation, we provide them with a clear competitive edge with GreenIntelligence for intelligent control and interconnection of fans, drives and systems to make applications more powerful, processes more efficient, businesses more successful and their customers more satisfied.

For **industrial ventilation technology**, solutions are in demand that ensure top performance and operational reliability in every situation. GreenIntelligence gives you robust fan solutions with intelligent networking capabilities that provide reliable performance data and extensive control and monitoring functions. They ensure high levels of efficiency and system availability while guaranteeing maximum data security.

There is a lot of GreenIntelligence in our RadiPac with resonance detection:

- Increased functionality for fault analysis and rectification
- Easy condition monitoring with intuitive operation
- Full control over all settings and activities
- Avoidance of resonant operation, resulting in longer service life of fans and lower maintenance costs
- All required hardware and software components from a single supplier

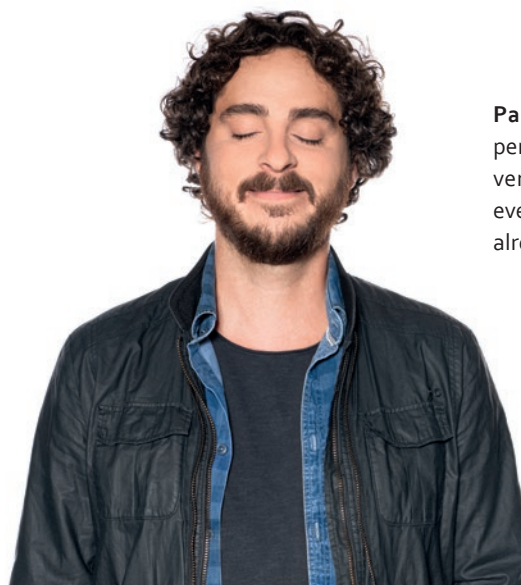

Pablo improves the performance of his ventilation systems even when they are already in operation.

The RadiPac is *self-sufficient*.

The challenge:

Centrifugal fans are used in various ventilation units and air conditioners. Depending on the installation situation, previously unforeseeable speed ranges may result in increased vibration levels in the resonant range. There are many reasons for this: a high residual imbalance (e.g. caused by transport and handling), changes in vibration behavior after installation in the customer's unit, and dirt adhering to the impeller. If the fan is operated frequently at excessive vibration levels, the bearings can be damaged and premature failures occur. Although these vibrations can be measured during commissioning of the plant, they cannot simply be eliminated.

The solution:

Vibration sensors in the RadiPac centrifugal fans detect the resonance, and the software prevents operation in the detected critical ranges. A test start-up is activated during commissioning. Here, the fan analyses the vibration severity across the entire speed control range and suggests ranges with too high a vibration velocity to hide. With simple confirmation, these critical speed ranges will be avoided in future operation.

An example:

In its as-delivered condition, every RadiPac centrifugal fan has its own resonant response which can be induced by the unavoidable residual imbalance. (Fig. 1 shows a RadiPac with the typical unique resonance characteristic.) If the fan is to be installed in a ventilation unit, this resonant frequency range may shift, and/or the vibration may increase to an impermissible level. Constant operation in an impermissible range could lead to premature failures (Fig. 2).

The vibration levels can also increase during continuous operation, for example due to dirt on the impeller and the resulting additional imbalance. It is exactly here that the innovative self-detection software of the RadiPac centrifugal fans takes center stage. The operator selects the commissioning routine during initial commissioning. In this procedure, the fan is started up from standstill all the way up to the nominal speed, and the vibration velocity is measured. If the software detects critical vibration velocity ranges, it suggests those speed ranges for suppression. This means that the ranges are passed through, but continuous operation in them is avoided (Fig. 3). Vibration induced by nearby equipment, such as compressors or condensers, can be detected but not avoided (Fig. 4).

Complete control

The ebm-papst EC-Control software includes everything you need for commissioning, condition monitoring and vibration analysis. That being said, you can adjust all settings manually, determine your own speed range values and define subsequent actions.

The most important functions at a glance:

- Simple status monitoring and vibration analysis
- Easy determination of resonant frequencies and suppression of critical speed ranges
- Warning in the event of imbalance

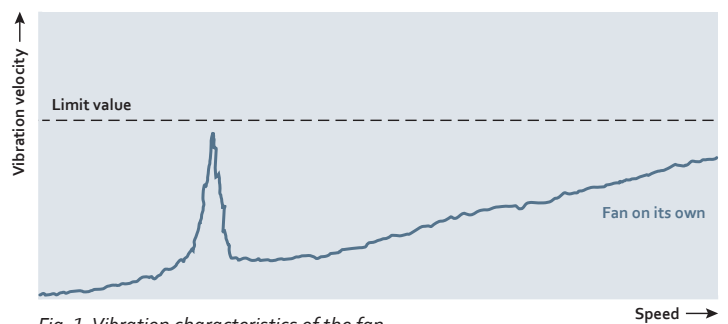

Fig. 1: Vibration characteristics of the fan

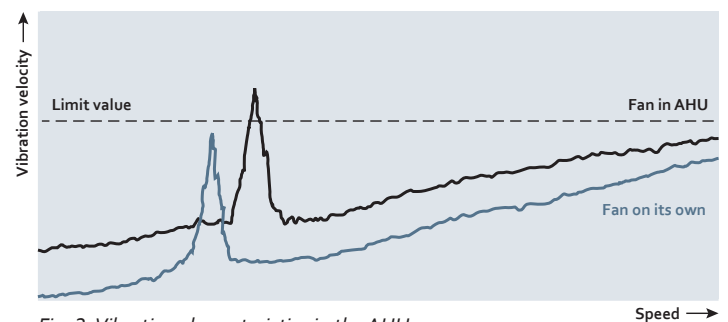

Fig. 2: Vibration characteristics in the AHU

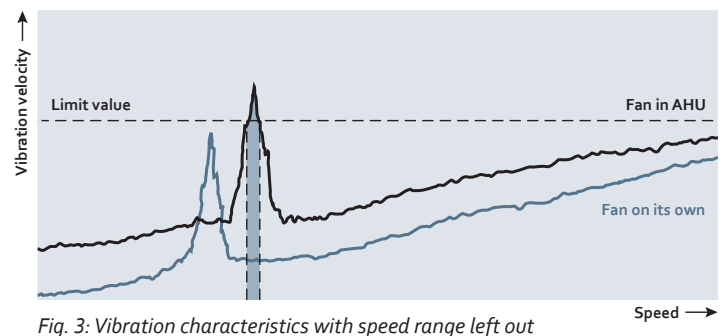

Fig. 3: Vibration characteristics with speed range left out

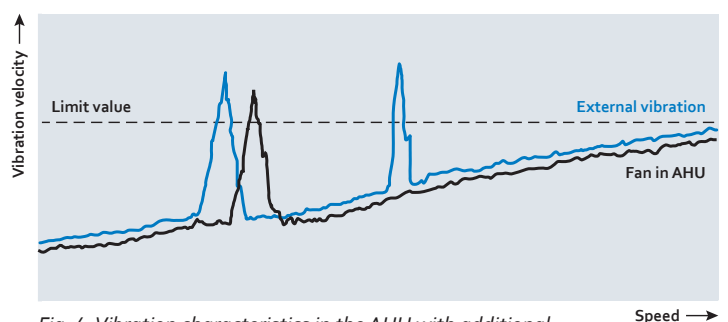

Fig. 4: Vibration characteristics in the AHU with additional external vibration source, e.g. compressor

First-rate design and monitoring *in every sense.*

High-performance impeller

- + High static efficiency**
 - Aerodynamically optimized blade channel
 - Aerodynamically optimized airfoil profile of the impeller blades (hollow chamber profile/airfoil profile)
 - Integrated radial diffuser
 - Inlet ring tuned to impeller
- + Low noise emission**
 - Diagonal trailing edge for optimal flow control
 - Integrated radial diffuser
- + Minimal vibration**
 - Dynamic balancing of impeller rotor unit minimizes induced structure-borne noise and reduces bearing load
 - Minimum residual imbalance thanks to complete balancing, meaning balancing only takes place after installation of all rotating parts (guaranteeing extremely smooth operation)
- + Rugged design**
 - Suitable for constantly high peripheral speeds
 - Corrosion-resistant aluminum
 - Airfoil blades for highest efficiency



Electronics and connection area

- + Adaptable**
 - Infinitely variable speed adjustment
 - Control signal 0–10 V DC and MODBUS
- + Universally deployable**
 - Wide voltage range for use worldwide
 - Suitable for use with 50 and 60 Hz networks
- + Safe operation**
 - Integrated locked-rotor and thermal overload protection
 - Environment-resistant cable glands
- + Simple commissioning**
 - Central terminal area for supply connection, alarm relay, as well as control and communication
 - Safe separation of terminal area and electronics
 - High-quality terminals
 - No adjustment required

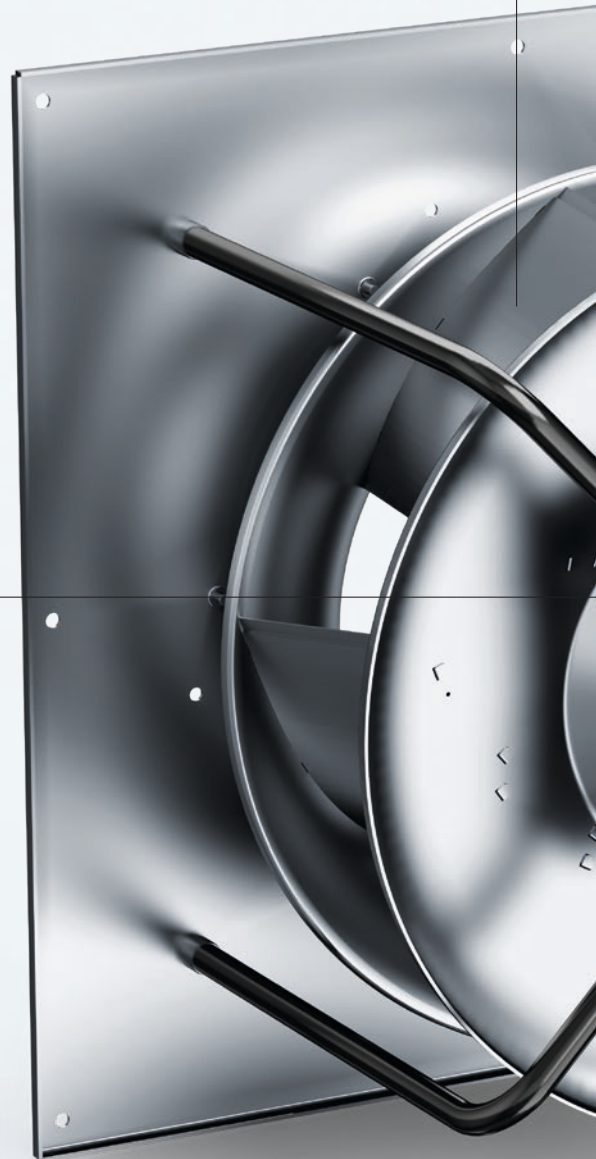

Resonance detection

- + **Increased functionality**
 - Simple status monitoring and vibration analysis
 - Test start-up during commissioning, including resonance point detection
 - Suggestion for suppression of critical speed ranges
- + **Intuitive operation**
 - Full control over all settings and activities
 - Hardware and software from a single supplier
- + **Longer service life and lower maintenance costs**
 - High vibration ranges are automatically avoided
 - Warning in case of permanent imbalance



Support bracket

- + **Easy installation in AHU**
 - Complete system for quick and easy installation
 - Nozzle plate for easy attachment of fan to equipment wall
 - Installation with horizontal OR vertical motor shaft
 - Compactness enables new design flexibility
- + **Aerodynamically perfected**
 - Aerodynamically efficient
 - Optimized factory positioning of nozzle



GreenTech EC motor

- + **Unbeatably compact**
 - The impeller is mounted directly on the rotor of the motor
- + **High efficiency**
 - Low copper and iron losses
 - Synchronous running prevents slip losses
 - Use of permanent magnets prevents magnetic hysteresis losses in the rotor
- + **Economical operation**
 - Optimized commutation enables partial-load operation down to 1:10 with sustained high efficiency
- + **Low-noise emission**
 - Commutation and stator design ensure low-noise magnetization of main field
 - High, acoustically imperceptible cycle frequency
- + **Long service life**
 - Maintenance-free bearings
 - Brushless commutation
- + **Safe operation**
 - Insulated bearing system to prevent bearing currents



Outer dimensions ...

RadiPac centrifugal fans with status monitoring are available in the selected sizes 400–560, including support bracket. Thanks to the perfectly coordinated complete system and plug & play, installation is very easy - as is the digital connectivity for use of the described

functions by means of the EC-Control software. Even integration into existing building management systems is easy thanks to the MODBUS-RTU interface.

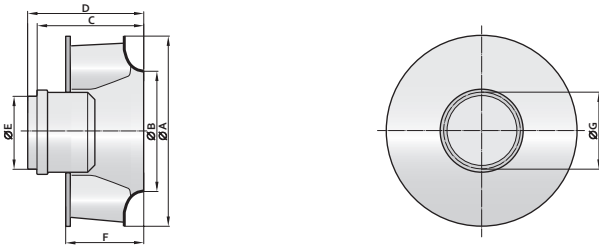

Motor with impeller

Item number	Size	A	B	C	D	E	F	G
R3G 400-PA27-65	400	455	285	225	343	232	225	252
R3G 450-PA31-65	450	530	320	304	374	232	254	252
R3G 500-PB24-65	500	585	535	336	406	232	282	252
R3G 560-PB31-65	560	585	355	336	406	232	282	252

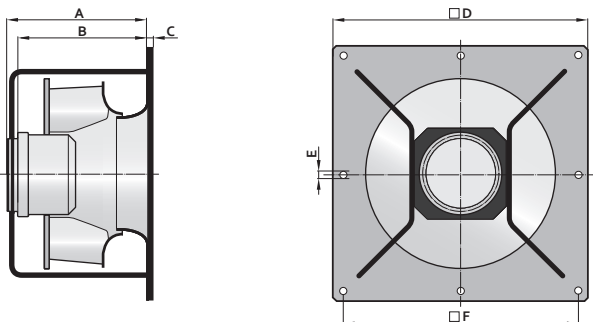

Support bracket

Item number	Size	A	B	C	D	E	F
K3G 400-PA27-65	400	389	319	15	500	∅ 11 (8x)	450
K3G 450-PA31-65	450	413	358	15	630	∅ 11 (8x)	580
K3G 500-PB24-65	500	459	389	15	630	∅ 11 (8x)	580
K3G 560-PB31-65	560	495	425	15	800	∅ 11 (8x)	750

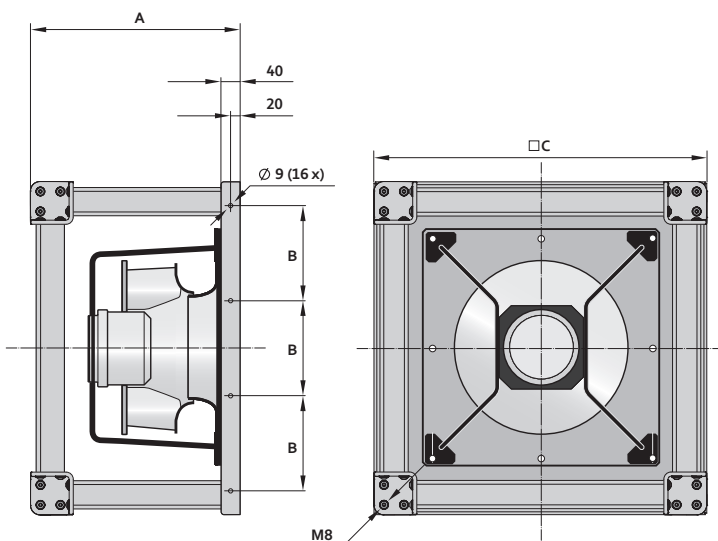

FanGrid cube with support bracket

Item number	Size	A	B	C
K3G 400-PA27-W5	400	522	200	699
K3G 450-PA31-W5	450	620	200	799
K3G 500-PB24-W5	500	651	225	899
K3G 560-PB31-W5	560	722	250	999

All dimensions in mm, data sheets on request. Subject to technical changes.

... and *inner* values.

Measurements for fan characteristic curves are carried out on state-of-the-art chamber test rigs. The entire fan unit, consisting of motor, control electronics and impeller, is measured in various load states to ensure that we obtain reliable data and that you can count on these values being achieved when selecting your fan. So, there are no unpleasant surprises when commissioning the fans.

The measured data form the basis for our design program, FanScout, which is available on request. This software can be used to calculate the expected operating costs or to perform lifecycle cost analyses.

Nominal data

Item number				Size	Nominal voltage range	Frequency	Speed ¹	Max. power consumption ¹	Max. input current ¹	Permitted ambient temperature
Motor with impeller	Support bracket	FanGrid cube			VAC	Hz	rpm	W	A	°C
R3G 400-PA27-65	K3G 400-PA27-65	K3G 400-PA27-W5	A	400	3- 380-480	50/60	2,800	3,650	5.5	-40 to +40
R3G 450-PA31-65	K3G 450-PA31-65	K3G 450-PA31-W5	B	450	3- 380-480	50/60	2,480	4,450	6.8	-40 to +45
R3G 500-PB24-65	K3G 500-PB24-65	K3G 500-PB24-W5	C	500	3- 380-480	50/60	2,000	3,900	6.0	-40 to +45
R3G 560-PB31-65	K3G 560-PB31-65	K3G 560-PB31-W5	D	560	3- 380-480	50/60	1,700	4,250	6.5	-40 to +40

¹Nominal data at operating point with maximum load and 400 VAC.
Data sheets on request. Subject to technical changes.

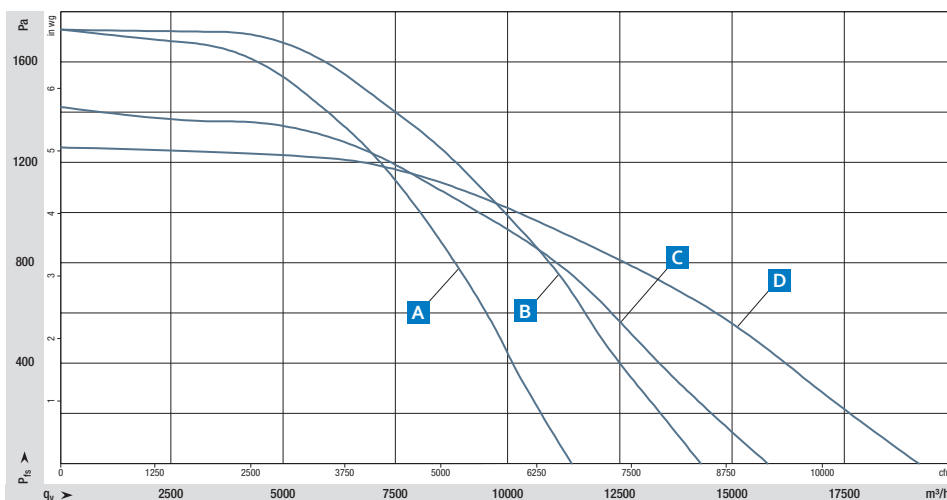

Would you like to find out more?

We are happy to assist you: Please get in touch with your regional sales contact or email info1@de.ebmpapst.com

or follow us at: www.ebmpapst.com/monitoring

www.ebmpapst.com

ebmpapst

the engineer's choice

ebm-papst Mulfingen GmbH & Co. KG

Bachmühle 2
74673 Mulfingen
Germany
Phone +49 7938 81-0
Fax +49 7938 81-110
info1@de.ebmpapst.com