

The innovative
Lambda**Constant** System

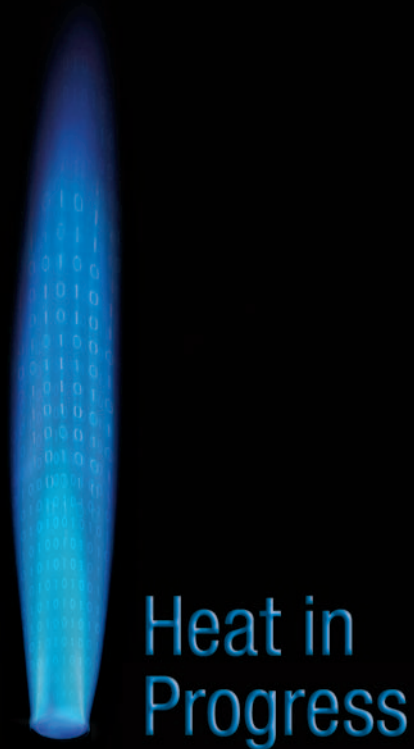

Intelligence and independence
for your condensing boiler systems

The engineer's choice

ebmpapst

The optimum setting – always and everywhere

Regardless of the type of gas, gas composition or location at which thermal heat is to be generated, an upper heating value burner with “built-in” LambdaConstant System automatically adjusts its output to a wide variety of basic conditions. Since its market launch in 2007, the LambdaConstant System – which consists of an intelligent ebm-papst gas blower and control unit – has already been used successfully in an increasing number of devices. As the first system to automatically self-regulate to a combustion level in the desired gas-air mixture ratio, it proves its superiority in the field of controlled, environmentally-friendly and highly efficient combustion.

Always at the optimum setting – regardless of the type and composition of gas

With conventional technology, upper heating value burners have required time-consuming adjustment and calibration. The LambdaConstant System now eliminates these tasks by adjusting automatically to various types of gas. Whether using natural gas, liquid gas, biogas or hydrogen-enhanced gas, the microprocessor-controlled LambdaConstant System automatically detects the combustion quality and optimises it using a closed-loop control system. Particularly in markets with variable gas compositions, this enables optimum, constant combustion. Thus the LambdaConstant System allows for fewer heating unit types. In addition, the detection within the gas type and automatic changeover between natural gas and liquid gas allow the mechanical switchover for the installer to be omitted.

Always at the optimal setting – regardless of where it is used

The actual maximum output of condensing boilers depends greatly on external conditions. For example, barometric air pressure, wind effects, and even the length of the flue gas tract can influence the attainable output. Here too, the LambdaConstant System’s integrated mass flow controller ensures that the gas unit adjusts itself, thereby guaranteeing regulated, environmentally responsible and efficient combustion from the very start.

Always energy-efficient – thanks to a one-of-a-kind degree of modulation

New condensing boiler technology with the LambdaConstant achieves unprecedented modulation levels of 1:10, compared to 1:5 for heating units with a pneumatic gas-air mixture. This is ensured by the ebm-papst control valve with high-precision stepper motor attached in modular form to the LambdaConstant blower. Thanks to the high modulation range, a vast variety of output requirements – from minimal heat output needs to full power output for hot water supply – can be met with precision. This critical advantage shows its full potential in modern low-energy buildings with high hot-water consumption. It also makes an important contribution to increasing the efficiency and environmental performance of modern gas-fired boilers.

In gas combustion, the burner temperature is always proportional to the air requirements for combustion. An example: 24 kW of power is demanded by the heater control system. This necessitates an air mass flow of 8 g/s and thus an optimal burner temperature of 300 °C. The LambdaConstant System adjusts the gas/air mixture until the optimum temperature has been achieved.

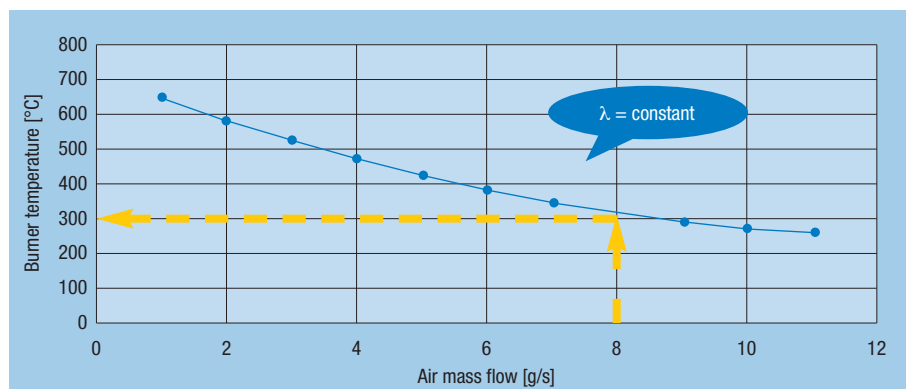

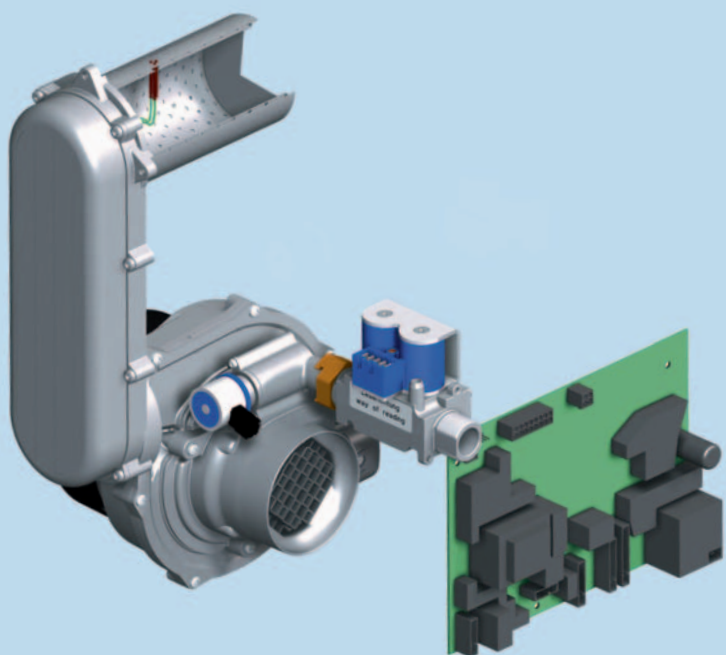

LambdaConstant System: Burner in conjunction with mass flow controlled gas blower and control

**As easy as it is resourceful –
the functionality of the LambdaConstant System**

In developing the LambdaConstant System, we simply applied a principle gained from research: for every gas type or gas family, it is possible to represent the dependency of temperature of air masses with a fixed Lambda value in a diagram. This, precisely, is the basis of the LambdaConstant System. With temperature and air mass measurements, the intelligent control system electronics can detect whether the system has reached its optimum level of efficiency, and adjust it as necessary. In doing so, the digital technology guarantees accurate fault detection or maximum intrinsic safety of the system (safety class C).

At a glance – the advantages of the LambdaConstant System

Burner temperature control independent of gas quality

- Air-gas ratio is practically independent of gas quality, gas or gas family (natural gas, liquid gas, biogas, hydrogen-enhanced gas)
- Stable measuring point, protected from direct flame, clearly positioned

Burner load independent of ambient conditions

- Flue pipe length adjustment
- Ignition load in optimum range
- Compensation for wind effects
- Automatic detection of clogged exhaust pipe with mass flow sensor

Never-before-seen modulation range

- 1:10 compared to 1:5 for pneumatic heating units
- Fewer clock cycles mean reduced alternating loads
- Higher partial-load efficiency at constant flow temperatures
- Optimal for low-energy buildings with high hot-water consumption

Control with high-precision electronic stepper motor valve

- Rigid system reduces noise
- No gas type changeover necessary

Reduction of heating unit types

- One type for natural gas and liquid gas
- Fewer types for various output ratings



With the Lambda**Constant** System, our customers are opting for a new, currently one-of-a-kind technology in the heating industry – with intelligent control and equally robust components that will generate upper heating values ruggedly and reliably throughout the entire service life. Of course, ebm-papst would not be ebm-papst if we were not determined to optimise this “revolution” in heating engineering even further, perfecting it to meet your needs. Naturally, in doing so, we can adapt the control system electronics to meet the individual requirements of your application. Contact us today about your needs and to obtain information on all of the essential details. We are glad to be of assistance.

ebm-papst Landshut GmbH

Hofmark-Aich-Straße 25
D-84030 Landshut
Phone +49 (0) 871 / 707-0
Fax +49 (0) 871 / 707-465
info3@de.ebmpapst.com

www.ebmpapst.com